

---

# COMBAT

# T-440 TRANS



Service Manual

2022

# Contents

<b>1. OVERVIEW .....</b>	<b>1</b>
1.1. SCOPE OF MANUAL.....	1
1.2. SAFETY PRECAUTIONS .....	1
<b>2. PRODUCT CONTROLS AND LED INDICATOR INTRODUCTION .....</b>	<b>2</b>
2.1. PRODUCT CONTROLS .....	2
2.2. LED INDICATOR .....	3
<b>3. CIRCUIT DESCRIPTION .....</b>	<b>3</b>
3.1. RF CIRCUIT .....	3
3.1.1. Tx Circuit .....	4
3.1.2. RF Power Amplifier Module Circuit .....	5
3.1.3. Rx Module Circuit.....	6
3.2. GPS CIRCUIT .....	8
3.3. BASEBAND SECTION .....	9
3.3.1. Circuit Description.....	9
3.3.2. Power Section.....	11
3.3.3. Audio Processing .....	14
3.3.4. Ethernet Interface.....	15
3.3.5. Boot Mode.....	15
3.3.6. Hardware Version Encode .....	16
3.3.7. Baseband Board Interface and Indicator .....	17
3.3.8. Tx Unit Interface Definition (J17) .....	18
3.3.9. RF Power Amplifier Module Interface (J18) .....	19
3.3.10. Rx Unit Interface Definition (J15) .....	20
3.3.11. Front Panel Interface Definition (J19).....	22
3.3.12. Serial Port Definition (J23).....	22
3.3.13. JTAG Simulator Interface Definition (J2) .....	23
3.3.14. External Interface Definition (J9).....	24
3.3.15. Case External Interface Definition .....	26
<b>4. FUNCTION AND PARAMETER SETTING.....</b>	<b>28</b>
4.1. CONVENTIONAL FUNCTIONS .....	28
4.2. PARAMETER SETTING .....	28
4.2.1. Parameters setting.....	29
4.2.2. Install CPSp user programming software .....	29
<b>5. ASSEMBLY AND DISASSEMBLY INSTRUCTION .....</b>	<b>32</b>
5.1. DUPLEXER ASSEMBLY .....	32
5.2. DISASSEMBLY INSTRUCTION.....	34
5.3. EXPLODED VIEW.....	36
5.4. CONNECTION.....	41

<b>6. ADJUSTMENT</b> .....	<b>44</b>
6.1. PREPARATION.....	44
6.2. METHOD OF MODULATION AND TEST .....	44
6.2.1. Local Oscillator Adjustment.....	44
6.2.2. Tx Adjustment.....	45
6.2.3. Rx Adjustment.....	47
<b>7. MAIN TECHNICAL FUNCTIONS AND SPECIFICATIONS</b> .....	<b>49</b>
<b>8. MAINTENANCE AND TEST EQUIPMENT</b> .....	<b>51</b>
<b>9. TROUBLESHOOTING</b> .....	<b>52</b>
<b>APPENDIX1 400-470MHZ UHF BAND SPARE PART LIST</b> .....	<b>55</b>
TABLE1 PARTS LIST (RX MODULE SECTION) .....	55
TABLE2 PARTS LIST (TX MODULE SECTION) .....	65
TABLE3 PARTS LIST (POWER AMPLIFICATION SECTION).....	72
TABLE4 PARTS LIST (BASEBAND MAINBOARD).....	76
TABLE5 PARTS LIST (FRONT PANEL) .....	84
TABLE6 PARTS LIST (POWER BOARD) .....	84
TABLE7 PARTS LIST (ACCESSORY BOARD).....	85
FIGURE 1 RX MODULE TOP BOARD PCB VIEW.....	86
FIGURE 2 RX MODULE BOTTOM BOARD PCB VIEW .....	87
FIGURE 3 TX MODULE TOP BOARD PCB VIEW .....	88
FIGURE 4 POWER AMPLIFIER MODULE TOP BOARD PCB VIEW.....	88
FIGURE 5 POWER AMPLIFIER MODULE BOTTOM BOARD PCB VIEW .....	89
FIGURE 6 BASEBAND MAINBOARD TOP BOARD PCB VIEW .....	90
FIGURE 7 BASEBAND MAINBOARD BOTTOM BOARD PCB VIEW.....	91
FIGURE 8 FRONT PANEL TOP BOARD PCB VIEW .....	92
FIGURE 9 FRONT PANEL BOTTOM BOARD PCB VIEW .....	92
FIGURE 10 POWER BOARD TOP BOARD PCB VIEW.....	93
FIGURE 11 ACCESSORY BOARD TOP BOARD PCB VIEW .....	94
FIGURE 12 ACCESSORY BOARD BOTTOM BOARD PCB VIEW .....	94
FIGURE 13 RX MODULE SCHEMATIC DIAGRAM .....	95
FIGURE 14 TX MODULE SCHEMATIC DIAGRAM .....	102
FIGURE 15 POWER AMPLIFIER MODULE SCHEMATIC DIAGRAM .....	107
FIGURE 16 BASEBAND MAINBOARD SCHEMATIC DIAGRAM.....	110
FIGURE 17 FRONT PANEL SCHEMATIC DIAGRAM.....	125
FIGURE 18 POWER BOARD SCHEMATIC DIAGRAM .....	126
FIGURE 19 ACCESSORY SCHEMATIC DIAGRAM.....	127
<b>APPENDIX2 136-174 MHZ VHF BAND SPARE PART LIST</b> .....	<b>128</b>
TABLE 1 PART LIST(RX MODULE SECTION) .....	128
TABLE 2 PART LIST(TX MODULE SECTION) .....	145
TABLE 3PART LIST(POWER AMPLIFICATION MODULE SECTION).....	151

TABLE 4 PART LIST(BASEBAND BOARD) ..... 155

TABLE 5 PART LIST(FRONT COVER) ..... 163

TABLE 6 PART LIST(POWER BOARD) ..... 163

TABLE 7 PART LIST(ACCESSORY BOARD)..... 164

FIGURE 1 RX MODULE TOP BOARD POSITION MARK DIAGRAM..... 165

FIGURE 2 RX MODULE BUTTOM BOARD POSITION MARK DIAGRAM..... 166

FIGURE 3 TX MODULE TOP BOARD POSITION MARK DIAGRAM..... 167

FIGURE 4 POWER AMPLIFIER MODULE TOP BOARD POSITION MARK DIAGRAM..... 167

FIGURE 5 POWER AMPLIFIER MODULE BUTTOM POSITION MARK DIAGRAM..... 168

FIGURE 6 BASEBAND MAINBOARD TOP BOARD POSITION MARK DIAGRAM ..... 169

FIGURE 7 BASEBAND MAINBOARD BUTTOM BOARD POSITION MARK DIAGRAM ..... 170

FIGURE 8 FRONT PANNEL TOP BOARD POSITION MARK DIAGRAM..... 171

FIGURE 9 FRONT PANNEL BUTTOM BOARD POSITION MARK DIAGRAM ..... 171

FIGURE 10 POWER BOARD TOP BOARD POSITION MARK DIAGRAM ..... 172

FIGURE 11 ACCESSORY BOARD TOP BOARD POSITION MARK DIAGRAM..... 173

FIGURE 12 ACCESSORY BUTTOM BOARD POSITION MARK DIAGRAM..... 173

FIGURE 13 RX MODULE SCHEMATIC DIAGRAM ..... 174

FIGURE 14 TX MODULE SCHEMATIC DIAGRAM ..... 181

FIGURE 15 POWER AMPLIFIER MODULE SCHEMATIC DIAGRAM ..... 186

FIGURE 16 BASEBAND MAINBOARD SCHEMATIC DIAGRAM..... 189

FIGURE 17 FRONT PANNEL SCHEMETIC DIAGRAM ..... 204

FIGURE 18 POWER BOARD SCHEMETIC ..... 205

FIGURE 19 ACCESSORY SCHEMATIC DIAGRAM..... 206



# 1. Overview

## 1.1. Scope of Manual

This manual is intended for use by trained engineers and professional technicians for the maintenance and repair of TR850 Repeater. Data changes in this manual may occur with the improvement of technology. To get the latest technology information, please contact us or your local distributors.

Before repairing the unit, please read this manual.

## 1.2. Safety Precautions

### Electromagnetic Radiation

Radios generate and radiate electromagnetic energy, the security design of Kirisun radios' electromagnetic radiation on human meets national and international standards.

### Electromagnetic Interference

Installation should be in accordance with local radio regulations.

### Explosive and Harmful Gases

Do not install the repeater in areas with explosive and harmful gases, such as the lower deck of the hull, fuel or chemical storage facilities, area where the air contains chemicals or particles, dust or metal dust.

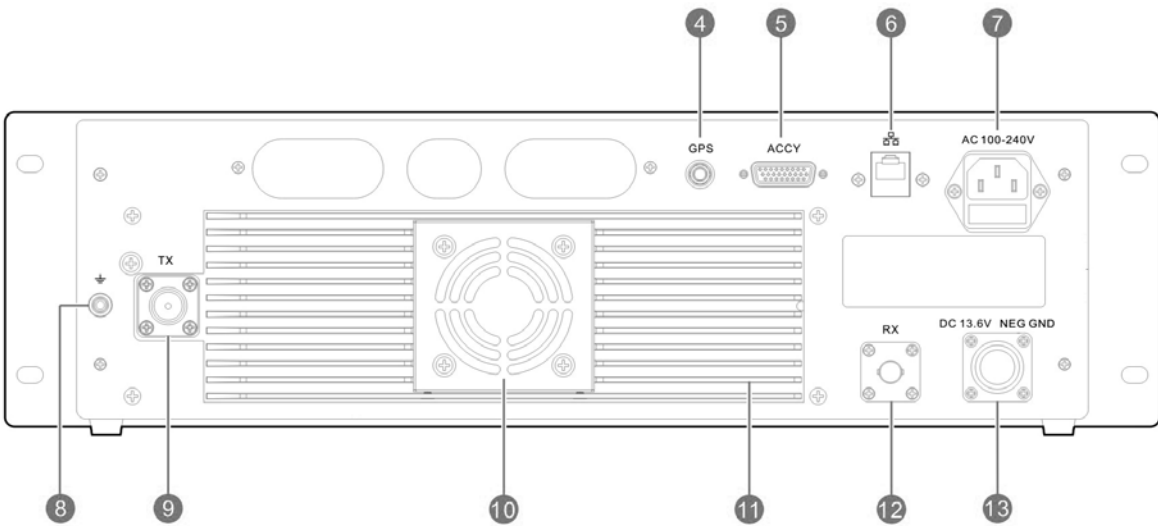
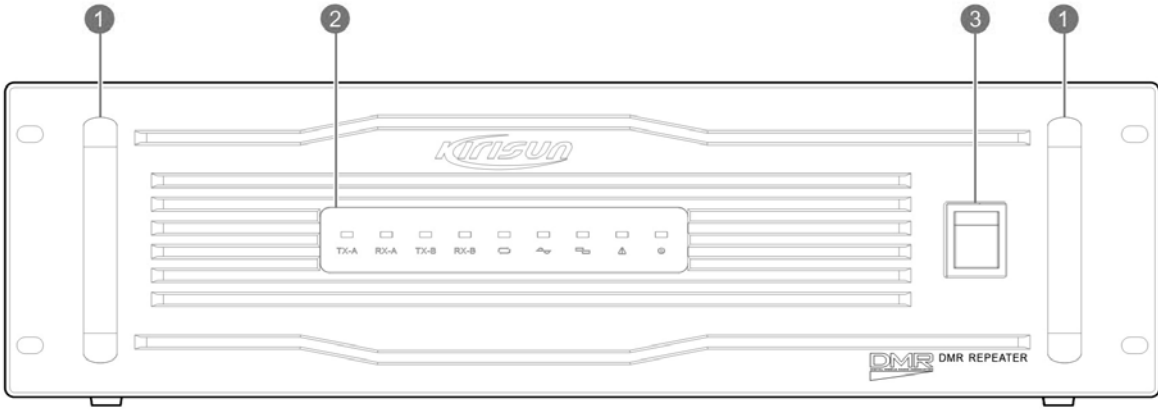
Do not install the repeater when close to the blasting area, electric blasting detonators.

### Replacement Parts

When replacing any replacement part, please be aware of the model. Do not arbitrarily replace the component that does not match with the radio.

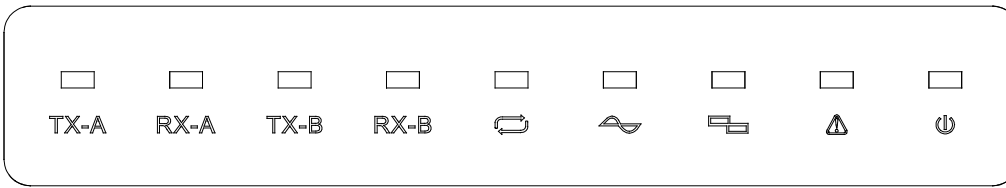
# 2. Product Controls and LED Indicator Introduction






## 2.1. Product Controls



No.	Part Name	No.	Part Name
1	Handle	2	Front Panel LED Indicator
3	Power Switch	4	GPS Antenna Connector
5	ACCY Connector	6	Internet Connector
7	AC Connector (with fuse)	8	Grounding ScREW
9	Transmit Antenna Connector (N)	10	Fan
11	Heat Sink	12	Receive Antenna Connector (BNC)
13	DC Connector	-	-

## 2.2.LED Indicator



LED	Description
TX-A	Indicates slot 1 is transmitting.
RX-A	Indicates slot 1 is receiving.
TX-B	Indicates slot 2 is transmitting.
RX-B	Indicates slot 2 is receiving.
	Repeater mode. When illuminated, the repeater is active. When the repeater is inactive, the LED is off.
	Analog mode. For analog or mixed signals the LED flashes when active. The LED is off when inactive.
	Digital mode. For digital or mixed signals the LED flashes when active. The LED is off when inactive.
	Alarm mode. Illuminates when there is a problem with the repeater.
	Illuminates when the repeater is switched on.

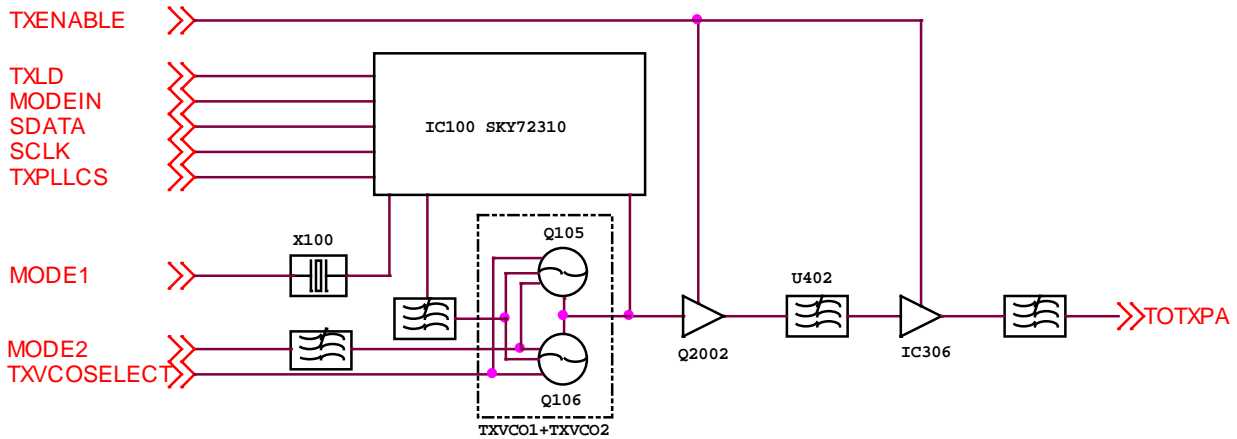
## 3. Circuit Description

### 3.1.RF Circuit

The RF part is composed of transmitter module, power amplifier module and receiver module.

### 3.1.1. Tx Circuit

Figure 3-1 Transmitter Circuit



Transmitter circuit includes three parts:

- Two Point Modulation Circuit

The RF center frequency calibration from the baseband and the low frequency part of 4FSK signal will be processed with addition algorithm, then sent to the DAC to get MODE1 signal. The MODE1 directly enters the reference clock X100, which is used for center frequency control and low frequency modulation. The MODE2 signal, which passes the two-level low pass filter which is composed of IC301s for DAC sampling interference filter, will be sent into VCO for high frequency part modulation.

- Transmitter Frequency Generation Unit Circuit

The transmitter PLL includes two VCOs, one PLL (IC100) IC SKY72310 and reference clock X100. The transmitting frequencies of the two VCOs controlled by the TXVCOSELECT signal are 400~435MHz and 435~470MHz respectively. (VHF is 136~155MHz and 155~174MHz)

a. Working Principle of Voltage Controlled Oscillator

The Tx Module employs two VCOs which cover the band of 400~435MHz and 435~470MHz (VHF is 136~155MHz and 155~174MHz). The switch of VCO is controlled by the TXVCOSELECT signal. VCO employs three point capacitance oscillation circuit. The VCO that covers the band of 400~435MHz (VHF is 136~155MHz) is composed of D106~D109, L119, Q106 and some other components, while the VCO covers the band of 435~470MHz (VHF is 155~174MHz) is composed of D101~D104, L107, Q105 and some other components.

b. Working Principle of Frequency Generation Unit

The 12.8 MHz reference clock (X100) output signal which is controlled by MODE1 signal will enter the reference input port of PLL IC (IC100 SKY72310), then according to the configuration of register, it will be divided to get 3.2MHz reference frequency, and the frequency will be compared in phase difference with the signal generated by the frequency division which is resulted from the VCO's enter into the input port of PLL chip. The PLL (IC100 SKY72310) PD pin will output the positive or negative pulse current which is in output pulse width, is directly proportional to the aforementioned signal phase difference. When the pulse

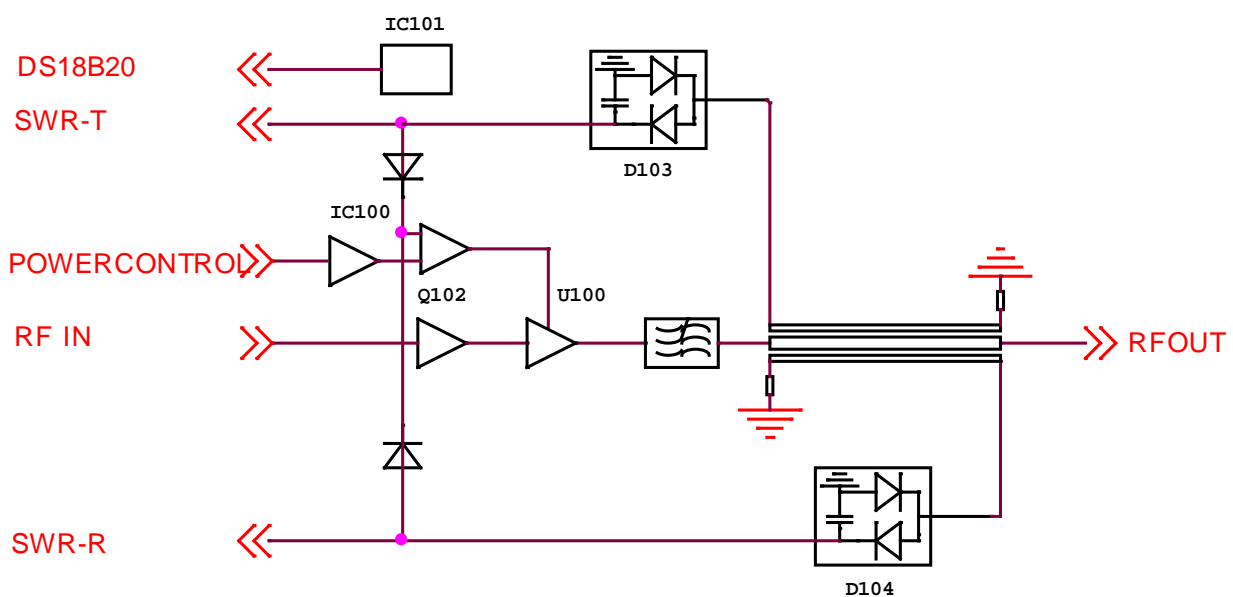
current passes the loop filter, it will be converted to CV voltage via RC integral. The the CV voltage will be sent to the VCO varactor to adjust and control the output frequency from the VCO until the CV voltage becomes constant. The loop is locked in the meantime.

- Buffer Amplifier Circuit

VCO outputs the modulated carrier signal to enter Q2002 for buffer amplification and then passes the LPF U402 to eliminate the harmonic wave. After that, the signal will go into IC306 for pre-amplification, then passes the LPF to filter the harmonic wave again, and the signal is output to the SMA connector which is connected to the transmitting power amplification.

### 3.1.2. RF Power Amplifier Module Circuit

Figure 3-2 RF power amplification module



The power amplifier module will amplify the modulated carrier signal from the transmitter module to a certain power level, then send to the transmitter port.

The power amplifier module includes the three parts:

- Power Amplification Part

The modulated carrier from the transmitter module will enter Q102 for pre-amplification, then the signal will attenuate to a certain level to make the amplitude of the signal which will be input with U100 operates between 17~20dBm. Under the control of POWERCONTROL signal, the RF signal output from U100 will pass the LPF to suppress the harmonic wave and collect power stationary wave sample from the directional coupler before being sent to the antenna port.

- APC and Stationary Wave Protection Circuit

The directional coupler detects the forward and reverse directions RF signal and passes the Q103,Q104 to convert the signal to the DC voltage which is corresponding to the forward and reverse direction power. After the voltage division, the forward direction DC voltage with the reverse direction voltage pass the selection switch which is composed of D201,D202 and enter IC100(NJM2904) for buffer amplification before being sent to the reverse phase input port of the operational amplifier of IC100(NJM2904). The

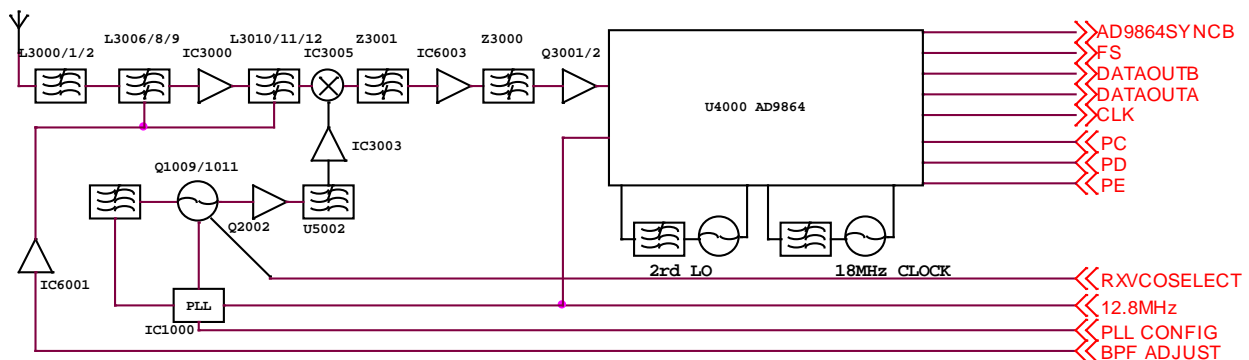
POWERCONTROL control signal from the baseband will be sent to the identical phase input port of IC100(NJM2904)'s operational amplifier. After the operational amplification and external circuit's function calculation, the signal is output as a control signal which controls the U100 gain control port to ensure that the actual output power remains stable when the impedance matches and to decrease the output power for power amplifier protection when the impedance mismatches.

- Temperature Detection Circuit

The continuous temperature rise can lead to a decrease of transmitting power. The temperature detection employs IC101(DS18B20) to collect the digital temperature sample. When the temperature exceeds the threshold value, the fan will be switched on for heat dissipation.

### 3.1.3. Rx Module Circuit

Figure 3-3 Receiver Module



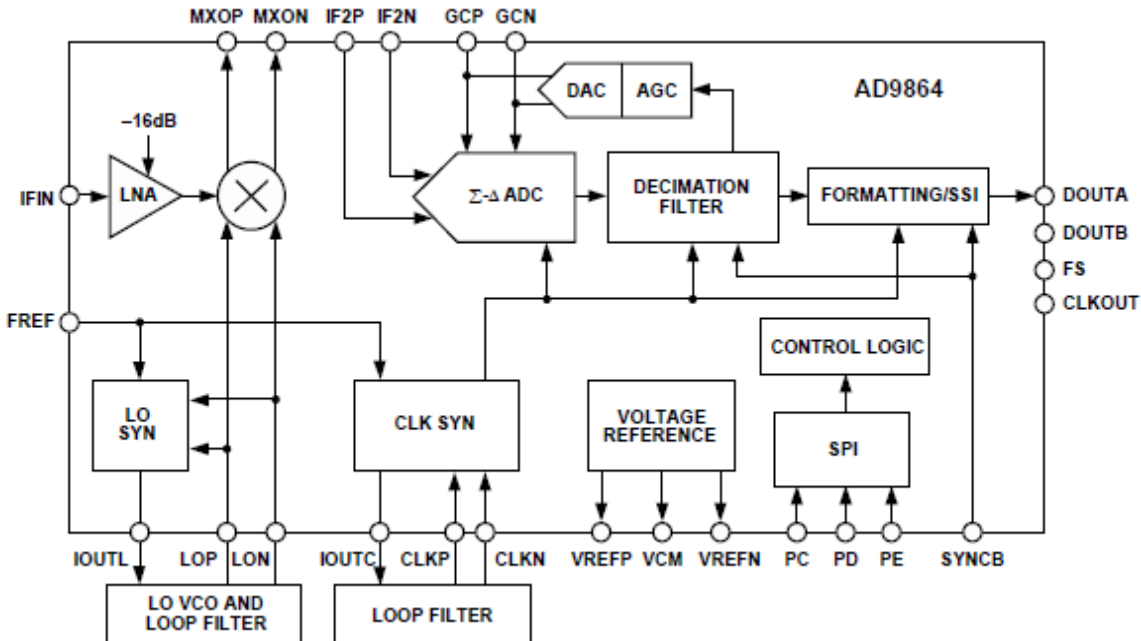
- Receiver Circuit

The receiver circuit includes RF Band pass filter, Low-noise amplifier, mixer, IF filter, IF amplifier and IF processor.

The signal from the receiving port first passes the low pass filter to suppress the high frequency interference, and passes the electrical tuning BPF to suppress the image interference and the out-band interference. The in-band signal is sent to the low noise amplifier (IC3000) and the amplified signal passes the electrical tuning BPF controlled by BPFADJUST to filter the out-band interference, so the effective high frequency will be sent to the mixer (IC3005). Meanwhile, the first local oscillation passes the LPF and gets mixed with the effective signal in IC3005 to generate the first IF signal (51.65MHz). The first IF signal passes the crystal filter (Z3001) to suppress the out-band signal. The signal is then sent to IF amplifier (IC6003) for amplification before being sent to the crystal filter to strengthen the suppression of the adjacent channel. After being sent to the limiting amplifier composed of Q3001 and Q3002, the signal enters AD9864 (U4000) for the second frequency mixing, IF amplification and AD sampling. The digital IQ signal will be finally output to the baseband for further processing.

- IF Processor Circuit

Figure 3-4 IF Processor



The 51.65MHz IF signal output from the IF amplifier enters the AD9864 via its pin 47, and it finishes the second frequency mixing in the AD9864 to convert the first IF to the second IF. The second IF signal is converted to the digital signal through the ADC sampling and output from the SSI port, and the digital signal is sent to FPGA for demodulation.

The reference frequency of AD9864 is 12.8MHz. The second local oscillation VCO is composed of external oscillation tube, varactor, and related components. The VCO provides the 49.4MHz local oscillation signal. The clock frequency of AD9864 is 18MHz and it is generated by external LC resonance circuit.

- Rx Module Frequency Generation Unit Circuit

The Rx Module Frequency Generation Unit Circuit is composed of two VCOs and one PLL. Two VCOs cover the band of 400~435MHz and 435~470MHz respectively (VHF is 136~155MHz and 155~174MHz).

a. Working Principle of PLL

The 12.8MHz clock frequency provided by the baseband will enter the frequency divider for division, and then the 3.2MHz phase detecting frequency will be generated. The signal generated by VCO enters the PLL chip for frequency division, and goes into the PD to get compared in phase difference with the signal generated by frequency division of reference clock, thus the continuous pulse current is generated. The continuous pulse current passes the loop filter and will be converted to CV voltage via RC integral. The CV voltage will be sent to the varactor, and it controls and adjusts the VCO output frequency until the CV becomes constant. In the mean time, the PLL is locked, and the stable output frequency from VCO passes the two buffer amplifier to enter the frequency mixer.

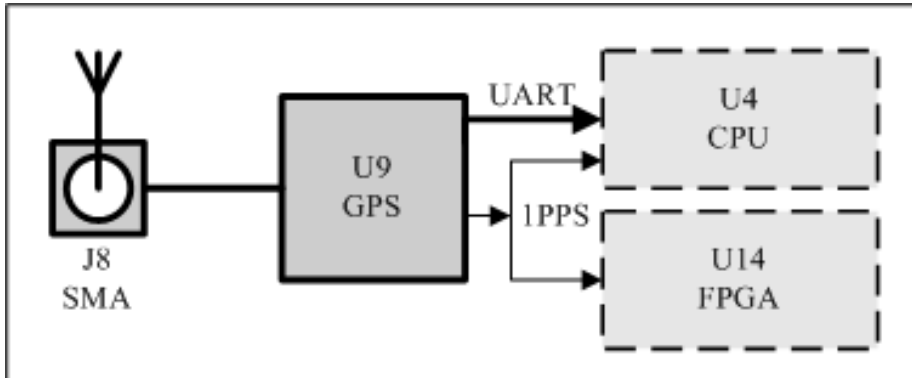
b. Working Principle of VCO

The Rx module employs two VCOs which cover the band of 348.35~383.35MHz and 383.35~418.35MHz

(VHF is 84.35~103.35MHz and 103.35~122.35MHz) respectively, and the switch of VCO is controlled by the RXVCOSELECT signal. VCO employs three point capacitance oscillation circuit. The VCO that covers the band of 348.35~383.35MHz (VHF is 84.35~103.35MHz) is composed of D1006~D1009、L1017、Q1011 and some other components, while while the VCO covers the band of 383.35~418.35MHz (VHF is 103.35~122.35MHz) is composed of D1002~D1005、L1016、Q1009 and some other components.

## 3.2. GPS Circuit

Figure 3-5 GPS Schematic Diagram



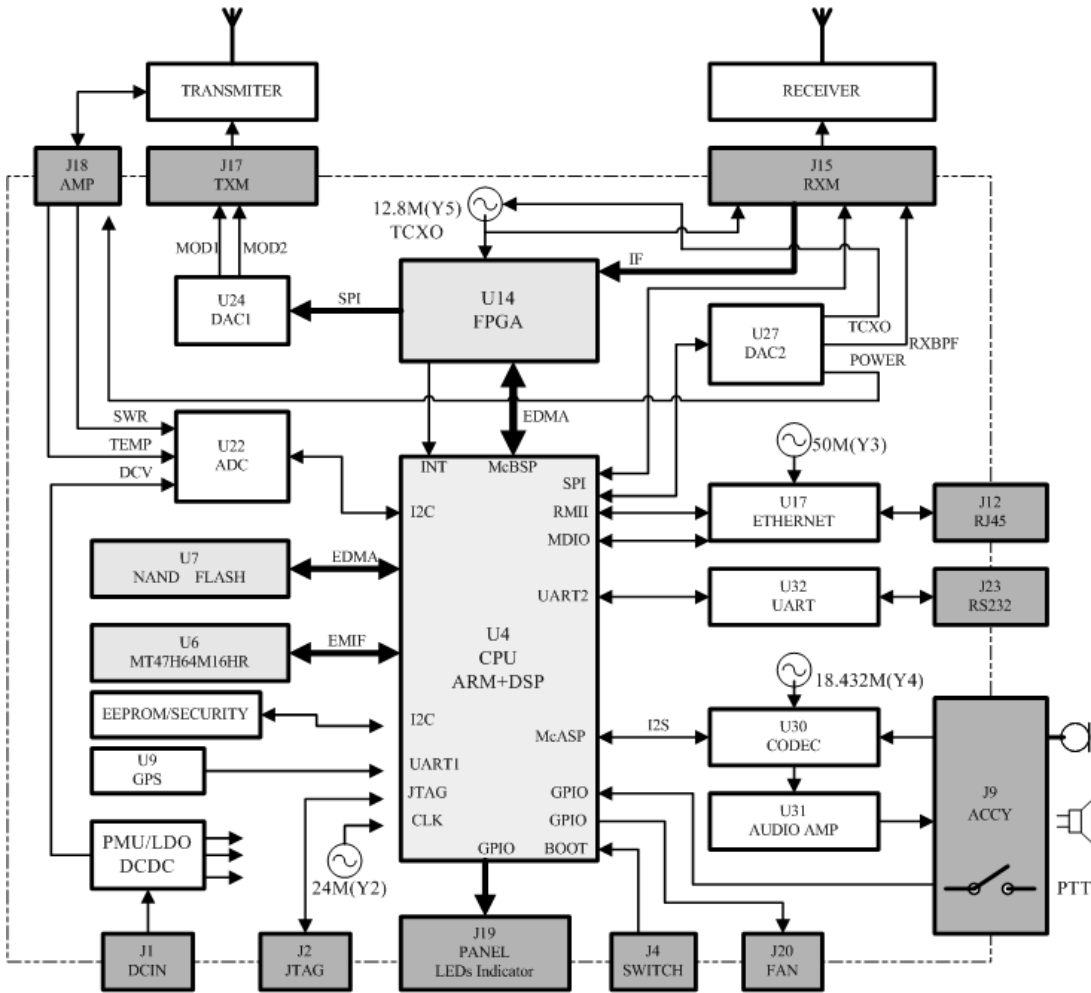
As Figure 3-5 shows, the repeater baseband board includes the GPS module (U9) and the GPS antenna interface J8(SMA). The corresponding equipment box is also assembled with a GPS antenna interface which supports the outdoor active antenna. The GPS module integrates a baseband processor, LNA and SAW. The antenna receives the 1575.42MHz GPS signal, after the inner amplification and filter process, it will be sent to the baseband section for further calculating, to get the geographical location and time information of the equipment. The output data information will be sent to processor (U4). Meanwhile, the GPS module hardware will provide the one-pulse-per-second signal (1PPS) for OMAP and FPGA respectively.



### 3.3. Baseband Section

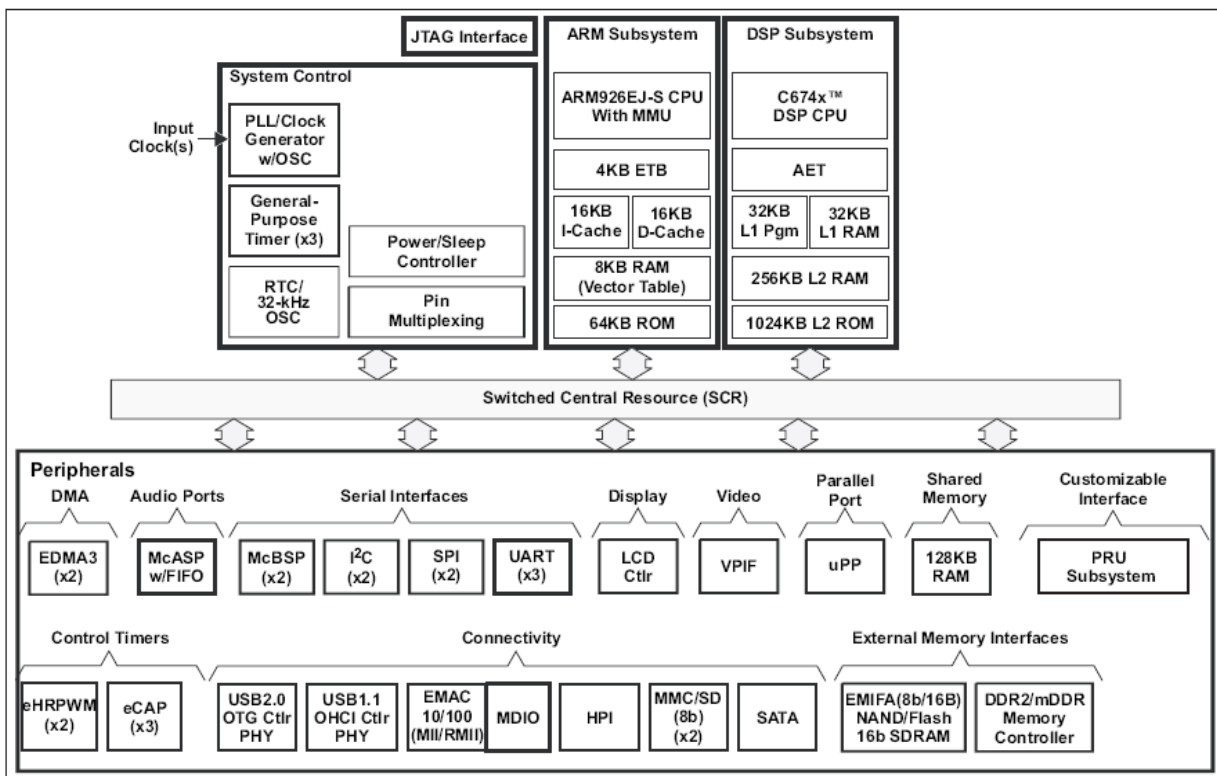
#### 3.3.1. Circuit Description

Figure 3-6 Baseband Circuit



As Figure 3-6 shows, inside the dotted line box is the baseband section circuits, which includes the four major modules of dual core processor(U4), DDR2(U6), NAND FLASH(U7) and FPGA (U14). They are used to run the Linux operation system with various drivers and protocols to achieve call forwarding.

Figure 3-7 Processor Internal Circuit



The internal circuit of the processor is as Figure 3-7 shows, which is composed of various serial interfaces such as 300MHz ARM926EJ MPU, 300MHz C674x DSP, DMA controller, SDRAM EMIF interface, EMAC Ethernet IC RMII interface, McASP digital audio interface and McBSP, SPI, I2C, UART.

- U6 is DDR2 SDRAM with the capacity of 1Gb(64Mx16), and it is used to store the running program codes and various dynamic data.
- U7 is NAND FLASH with the capacity of 2GB, and it is used to store the drivers of all the devices, operation system and application program code which includes the program code of FPGA.
- The digital IF signal sent from the FPGA processing receiving unit communicate with the processor U4 via EMA BUS, and it communicate with DAC via the analog SPI interface to process the transmitting and receiving data, which includes the data framing, filter, interpolation, extracting and etc. to achieve the calculation and synchronization of frame number. The PLL module inside the FPGA IC will process the external 12.8MHz, +/-1.5ppm reference clock to generate a 61.44MHz master clock via 24/5 frequency doubling and frequency division.

The external circuit includes the parts of ADC, DAC, CODEC, AUDIO AMP, ETHERNET, RS232 and etc.

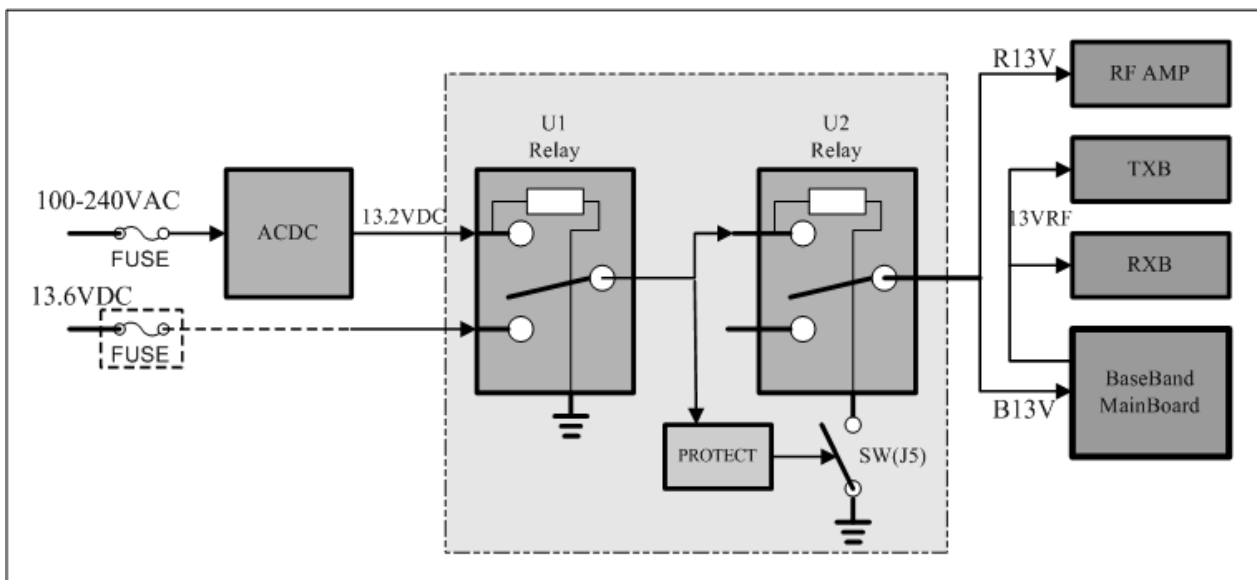
- The Analog-Digital Convertor ADC (U22) collects data such as stationary wave signal detection and power supply voltage detection which are controlled by RF power.
- Digital-Analog Convertor DAC (U24) is used for transmitter two point modulation output, and the other DAC(U27) is used to achieve the band pass adjusting and the RF power amplification control of the RF receiver, the tuning control of the receiver local oscillation reference clock.
- CODEC(U30) achieves the digital-analog converting. It is connected to the OMAP processor via I2S digital audio interface to achieve the local monitoring, output and input of interposed speech or audio

Tx/Rx index testing.

- The output power of audio power amplifier (U31) is 1W, which is used for local monitoring or tested speech output.
- Network interface (U17) is the TRx components of 10/100M single Ethernet physical layer, and it is used to the tuning of various parameter setting and communication control.
- UART- Universal Asynchronous Receiver/Transmitter(U32)achieves the RS232 electrical level switch, when it communicates with the PC, it can initiate the programming burning, programming tuning information printing, and etc.

### 3.3.2. Power Section

Figure 3-8 Whole Unit Power



As Figure 3-8 shows, the whole unit power supply employs adaptive ac/dc power supply with AC priority and DC/AC auto switch. The output DC voltage which is switched and protected by the electric relay will be divided into two paths. One path is for the RF power amplification, and the other is for banseband mainboard. The switch in the front panel turns the power on/off via the electric relay U2. The protection circuit will cut off all the DC output when the DC exceeds 18V.

The AC/DC switching part employs an independent module power supply(320W), and it supports the AC input range between 100V-240V, nominal output DC voltage is 12V, and the factory set is 13.2V.

The rated AC input voltage is between 100-240V, the socket is built in the dual protective tube. Specification of the protective tube is 2.5A, 5x20mm ceramic tube, slow type.

The rated DC input voltage is 13.6V with the rated current being 15A. The protective tube is included in the DC accessories.

#### Power Switch and AC/DC Switch

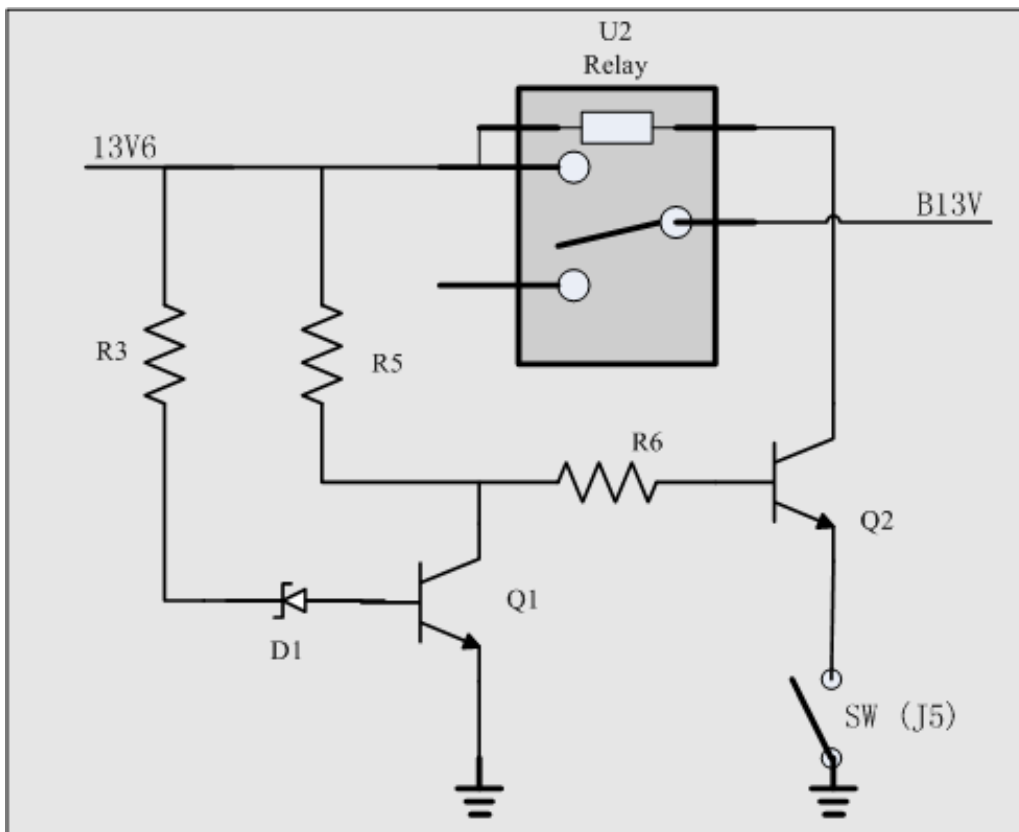
As the Figure 3-8 shows, the electric relay is switched on for the AC power supply and it will cut off the DC point. The 13.2VDC output from the ACDC module is connected to U2 through the U1 contact. If the panel switch (J5) is on, the electric relay (U2) will be switched on, so is the repeater.

When AC power supply is off, the electric relay (U1) is released. The DC is connected to U2 via the electric relay (U1) contact. If the panel switch (J5) is on, the electric relay U2 will be switched on, so is the repeater.

The panel switch (J5) is off, and U2 is released, which cut off the baseband DC power supply B13V including the RF power supply R13V.

## Over-voltage Protection

Figure 3-9 Over-voltage Circuit Protection



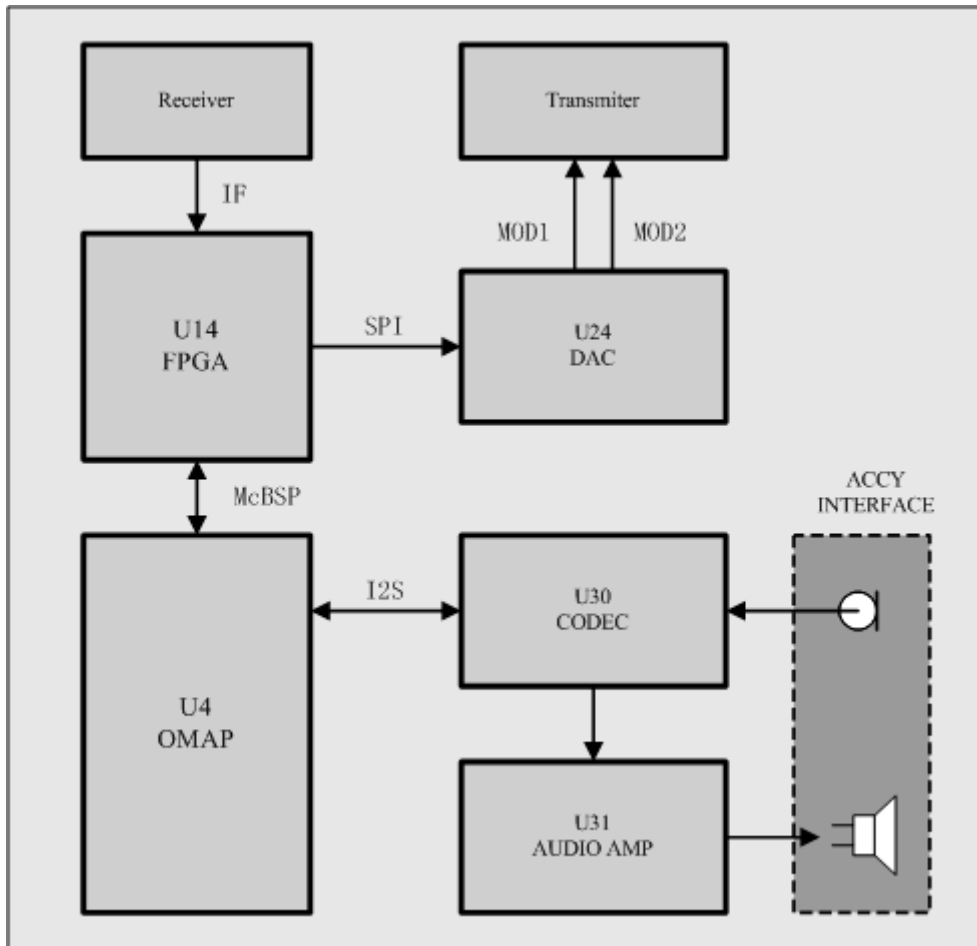
As the Figure 3-9 shows, the breakdown voltage of the voltage stabilizing diode is  $18V \pm 0.5V$ . If the input DC voltage is over  $18V \pm 0.5V$ , the Q1 breaks over with Q2 being cut off, and the electric relay U2 will be released to cut off the DC power supply B13V, including the RF power supply R13V.



(U5) and provide it for the analog power of CODEC (U30).

### 3.3.3. Audio Processing

Figure 3-11 Audio Processing Schematic Diagram



As the Figure 3-11 shows, the audio processing module mainly achieves encoding and decoding with ADC and DAC of the audio signal, including air audio forwarding and local audio TRx.

- Air Audio Forwarding

The digital IF signal from the RF receiver will be first sent to the FPGA(U14) for time slot processing and achieving the framing, filtering and extracting of the data to realize the calculation and synchronization of the frame number; the signal will be send to the DSP of CPU (U4)via the McBSP interface for 4FSK decoding, digital audio signal decoding and etc.. Meanwhile, the internal DSP will send the digital audio signal which achieves the decoding and encoding to the FPGA(U14) for time slot processing and finishing the framing, filtering and interpolation and other synchronization calculation of the data, and the digital audio signal will then be sent to the DAC (U24) via the SPI interface for the audio digital/analog switch, generating the analog speech two point modulation signal before being sent to the transmitter for the audio forwarding.

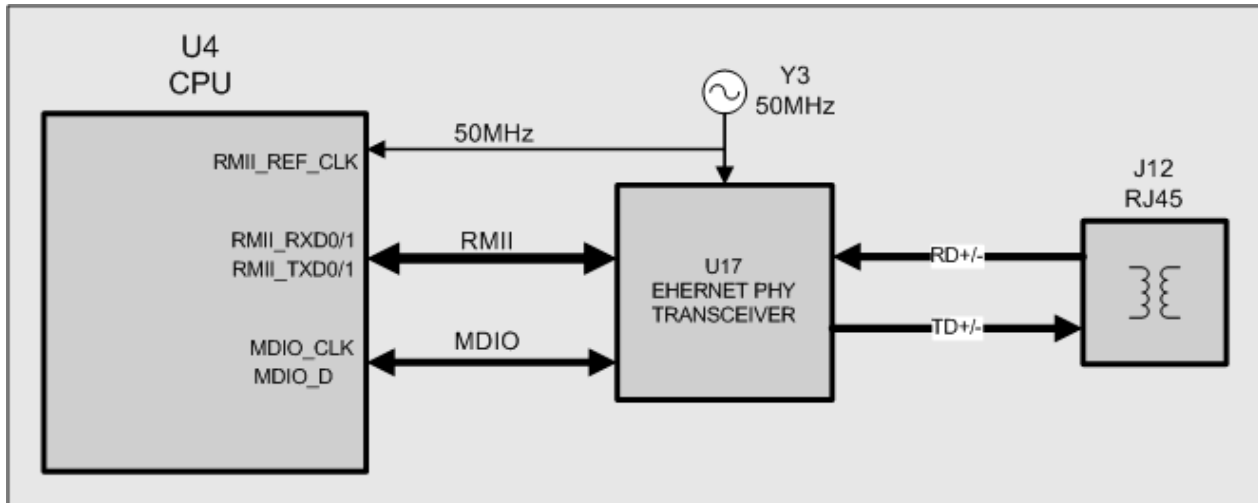
- Local Audio TRx

The internal DSP in the main processor(U4) connects to the CODEC(U30) via the I2S digital audio interface. The CODEC(U30) will convert the analog audio input from the external to digital audio, then

send into the internal DSP. In the meantime, converts the received digital audio from the internal DSP to analog audio, then send the audio to audio power amplifier(U31), before finally send to the ACCY external interface, which is to drive the 1W, 16Ω speaker.

### 3.3.4. Ethernet Interface

Figure 3-12 Ethernet Interface



As Figure 3-12 shows, A RMIi simplified interface is used between the CPU(U4) and network interface chip(U17). RMIi interface independent clock uses external clock mode and share 50MHz clock with U17.

CPU (U4) achieves the hardware information of internet interface U17 through the independent configuration interface MDIO. CPU also initiate it and assign MAC and IP address.

The data transmitting and receiving between network interface chip(U17) and interface connector(J12) are achieved through connecting the transformer inside the connector jack RJ45 and LED through 2 pairs of differential line.

The network interface can realize parameter adjustment and parameter configure, user programming and firmware upgrade.

### 3.3.5. Boot Mode

A boot mode selection switch (J4) is provided on the baseband. The four position 1 to 4 of DIP encode switcher are correspondingly connected with boot 1 to boot 4 of OMAP (U4), so the boot operation mode will be changed after being powered on.

The level of position "ON" of encode switcher corresponding to boot which is connected to GND is "0".Conversely, the level of position "OFF" is "1".

As showing in Figure 3-13, the level of boot1 to boot4 of switcher is 0101, and it enters to firmware download mode after power on. It can upgrade the guide program and the low driver program by booting from serial port(UART2).

Figure 3-13 Firmware Download Mode

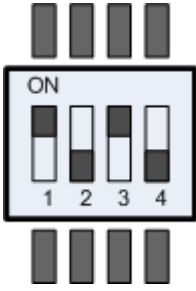
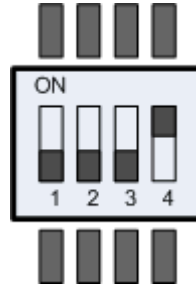


Figure 3-14 User Mode



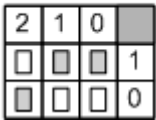
As showing in Figure 3-14, the level of boot 1 to boot4 is 1110, and it enters to normal running user mode after power on. It starts from NAND FLASH. In this mode, it can upgrade operation system kernel, device driver program, files system and application program by network interface.

Please configure the boot mode as user mode as shown in Figure 3-15 in normal use.

### 3.3.6. Hardware Version Encode

Figure 3-15 Hardware Version Encode

Hardware code



According to the position of chip resistor in Figure 3-15 the encoder is “001” and the corresponding version is Ver3.0.

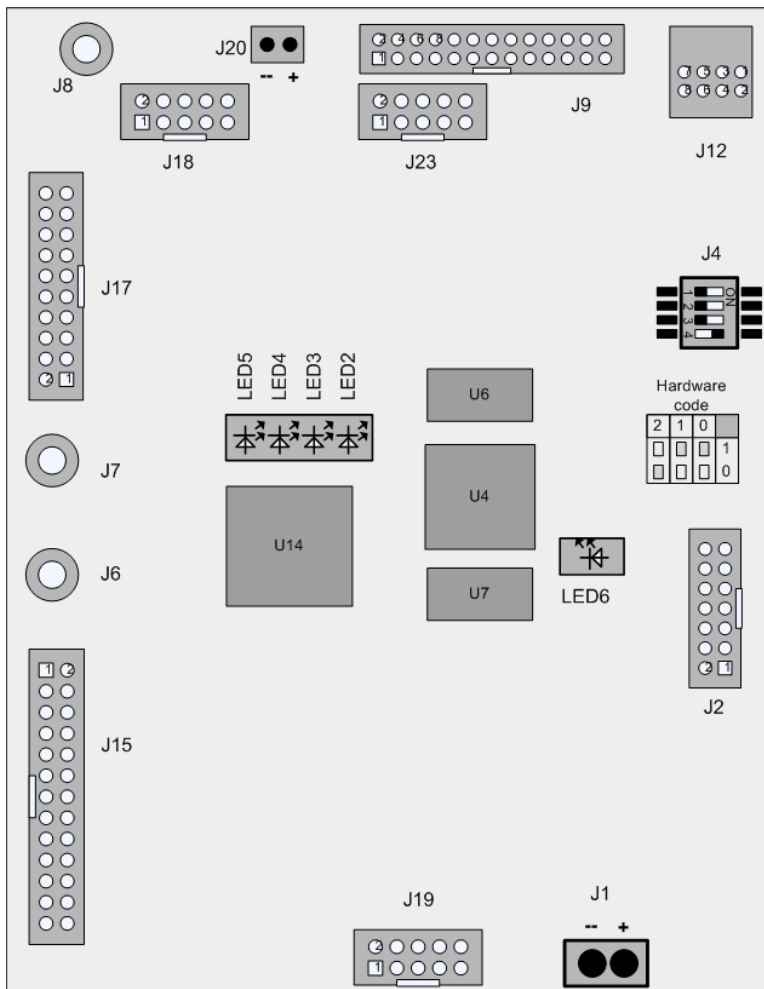
2	1	0		D2	D1	D0	Version
NULL	NULL	OR	1	0	0	1	Ver1.0
OR	OR	NULL	0				
NULL	OR	NULL	1	0	1	0	Ver2.0
OR	NULL	OR	0				
NULL	OR	OR	1	0	1	1	Ver3.0
OR	NULL	NULL	0				
OR	NULL	NULL	1	1	0	0	Ver4.0
NULL	OR	OR	0				
OR	NULL	OR	1	1	0	1	Ver5.0
NULL	NULL	NULL	0				



0R	0R	0R	1	1	1	0	Ver6.0
NULL	NULL	NULL	0				
0R	0R	0R	1	1	1	1	Ver7.0
NULL	NULL	NULL	0				

### 3.3.7. Baseband Board Interface and Indicator

Figure 3-16 Baseband Board Interface and Indicator



See Figure 3-16, The interfaces and indicators of baseband are as follows:

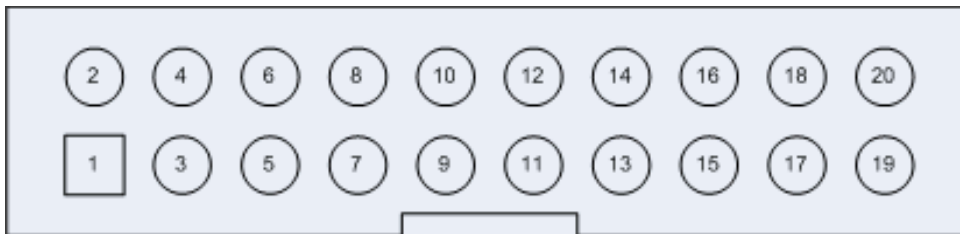
- J1 is the 13.2V(+/-20%) DC input interface of the whole baseband mainboard, and the polarity should be noted. The input circuit includes isolating magnetic inductor (L12) and chip insurance resistor (F1).
- J2 is the JTAG adjustment interface of main processor, and it is used for program simulation adjustment.
- J4 is the switch for boot mode. See “3.3.5 Boot Mode” for details.
- J6、J7 are 12.8MHz clock and SMA offered by main board to other parts. The two signals are the same

and either one of them can be selected.

- J8 is the interface and SMA of GPS interface, and it supports active antenna with 3.3V feed output.
- J9 is the ACCY external interface provided by baseband, and it is used for function expansion or test. It includes the input and output of local speech, external PTT, and programmable expansion IO. It provides 12V/1A DC output.
- J15 is the interface of Rx board, including digital IF, SPI interface signal, 12C interface signal for storing data of test and adjustment, etc.
- J17 is the interface of Tx board, including two point modulation signal, SPI interface of Tx circuit PLL, Tx control signal, etc.
- J18 is the control interface of RF power amplifier, including SWR , TEMP\_DET, POWER\_CONTROL, TX\_ENABLE, etc.
- J19 is the interface of LED status display board.
- J20 is the 12VDC fan interface. The fan will be switched on when the radio transmits or the temperature goes beyond the set range.
- J23 is the serial port UART2.
- LED2、LED3、LED4、LED5 indicates program operation status.
- LED6 indicates CPU power.

### 3.3.8. Tx Unit Interface Definition (J17)

Figure 3-17 Tx Unit Interface Definition



Terminal NO.	Terminal Name	I/O	Function
1	GND	-	Ground
2	MOD1	O	TX Modulate signal output1
3	GND	-	Ground
4	MOD2	O	TX Modulate signal output2
5	GND	-	Ground

6	NC	-	-
7	GND	-	Ground
8	NC	-	-
9	TX_LD	O	PLL locked indicate,active high
10	TX_VCO_SEL	O	Select VCO band
11	SPI_CLK	O	SPI clk
12	GND	-	Ground
13	VCCTX	O	Open TX Power,active high
14	GND	-	Ground
15	SPI_MOSI	I/O	SPI data
16	GND	-	Ground
17	PLL_CS	O	PLL chip selected,,active low
18	TX_ENABLE	O	Enable TX PLL,,active high
19	VCC	O	13.2V output
20	VCC	O	13.2V output

### 3.3.9. RF Power Amplifier Module Interface (J18)

Figure 3-18 RF Power Amplifier Module Interface



Terminal NO.	Terminal Name	I/O	Function
1	POWER_CTRL	O	POWER control output
2	GND	-	Ground
3	POWER_SWITCH	O	POWER switch,active high
4	NC	-	-
5	TX_ENABLE	O	Power module enable,active high
6	NC	-	-
7	SWR_R	I	Power SWR_R detector
8	TEMP_DET	I	Power temperature detector
9	SWR_T	I	Power SWR_T detector
10	NC	-	-

### 3.3.10. Rx Unit Interface Definition (J15)

Figure 3-19 Rx Unit Interface

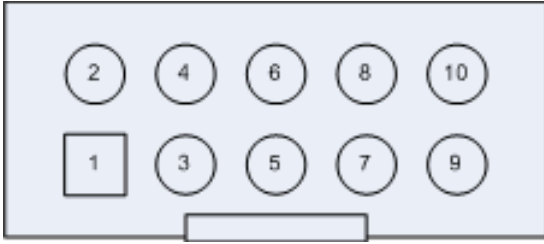


Terminal NO.	Terminal Name	I/O	Function
1	SYNCB	O	Resets AD9864 SSI and DecimatorCounters; Active Low
2	SPI_MISO	I	Data for AD9864 SPI
3	AD9864_DATAOUT	I	Data for AD9864 SSI
4	AD9864_CLK	I	Clock for AD9864 SSI

5	AD9864_FS	I	Frame synchronous for AD9864 SSI
6	SPI_CLK	O	Clock for AD9864 SPI
7	SPI_MOSI	O	Data for AD9864 SPI
8	AD9864_SPI_CS	O	Enable for AD9864 SPI
9	RX_VCO_CTRL	O	VCO tuner
10	RX_PLL_CS	O	PLL chip selected,active low
11	I2C_SDA	I/O	EEPROM data
12	I2C_SCL	O	EEPROM clock
13	RX_LD	O	PLL locked indicate,active high
14	GND	-	Ground
15	RX_BPF_CTRL	O	Output for RX BPF filter tuner
16	NC	-	-
17	VCCR8X	O	Open RX Power,active high
18	GND	-	Ground
19	RX_VCO_SEL	O	select VCO band
20	NC	-	-
21	I2C_A0	O	EEPROM address
22	NC	-	-
23	GND	-	Ground
24	NC	-	-
25	VCC	O	13.2V output
26	VCC	O	13.2V output

### 3.3.11. Front Panel Interface Definition (J19)

Figure 3-20 Front Panel Interface Definition



Terminal NO.	Terminal Name	I/O	Function
1	3V3	-	3.3V
2	GND	-	Ground
3	LED0	O	TX_A slot indicate,active high
4	LED4	O	REPEATER mode indicate,active high
5	LED1	O	RX_A slot indicate,active high
6	LED5	O	ANALOG mode indicate,active high
7	LED2	O	TX_B slot indicate,active high
8	LED6	O	DIGITAL mode indicate,active high
9	LED3	O	RX_B slot indicate,active high
10	LED7	O	ALARM indicate,active high

### 3.3.12. Serial Port Definition (J23)

Figure 3-21 Serial Port Definition



Terminal NO.	Terminal Name	I/O	Function
1	NC	-	-
2	NC	-	-
3	TXOUT	O	RS232 TX output
4	NC	-	-
5	RXIN	I	RS232 RX input
6	NC	-	-
7	NC	-	-
8	NC	-	-
9	GND	-	Ground
10	NC	-	-

### 3.3.13. JTAG Simulator Interface Definition (J2)

Figure 3-22 JTAG Simulator Interface Definition



Terminal NO.	Terminal Name	I/O	Function
1	TMS	-	TMS
2	TRST	-	TRST
3	-	-	-
4	-	-	-

5	-	-	-
6	NULL	-	NULL
7	-	-	-
8	-	-	-
9	-	-	-
10	-	-	-
11	-	-	-
12	-	-	-
13	-	-	-
14	-	-	-

### 3.3.14. External Interface Definition (J9)

Figure 3-23 External Interface Definition



Terminal NO.	Terminal Name	I/O	Function
1	USB_D+	I/O	Reserved
2	USB_D-	I/O	Reserved
3	V_BUS	O	Reserved
4	USB_GND	-	Ground
5	ACC_ID2	I	Reserved

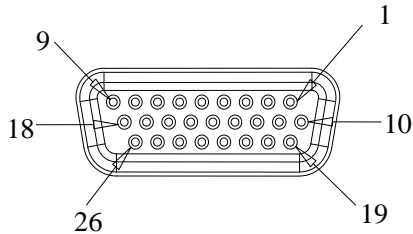


6	ACC_ID1	I	Reserved
7	EXT_SWB+	O	Power 13.2VDC switched output
8	POWER_GND	-	Ground
9	EXT_SPK-	O	Annalog output speaker-
10	EXT_SPK+	O	Analog output speaker+
11	TX_AUDIO	I	Analog audio input
12	AUDIO_GND	-	Ground
13	AUX_AUDIO_OUT1	O	Reserved
14	RX_AUDIO	I	Reserved
15	AUX_AUDIO_OUT2	O	Reserved
16	GND	-	Ground
17	PRGM_IO_1	I	PTT input,high active
18	GND	-	Ground
19	PRGM_IO_2	I/O	Reserved
20	PRGM_IO_6	I/O	Reserved
21	PRGM_IO_3	I/O	Reserved
22	PRGM_IO_7	O	Output high level(2.8V)
23	PRGM_IO_4	I/O	Reserved
24	PRGM_IO_8	I/O	Reserved
25	PRGM_IO_5	I/O	Reserved
26	PRGM_IO_9	I/O	Reserved

### 3.3.15. Case External Interface Definition

Extended interface (J9) of baseband is connected to accessory board by a flat gray cable, then connected to the ACCY connector at the rear of repeater after conversion through accessory board. The ACCY connector is as following Figure 3-24.

Figure 3-24 ACCY Interface



Terminal NO.	Terminal Name	I/O	Function
1	Ext_SWB+	+13V Output	+13.8V output(I <sub>max</sub> <1A)
2	GND	Ground	Ground
3	USB_D+	Reserved	
4	USB_D-	Reserved	
5	USB_VBUS	Reserved	
6	USB_GND	USB Ground	
7	Program_IN_1 (PTT)	External PTT Signal input, High level active .when connected with Pin20, enter transmission mode	Digital Input: (2.5V<V <sub>IH</sub> <3.3V,0V<V <sub>IL</sub> <0.4V)
8	Ext_Spk-	External Speaker output	8 Ω /16Ω, 0.8W Max
9	Ext_Spk+	External Speaker output	8 Ω /16Ω, 0.8W Max
10	ACC_MAP_ID_2	Accessory ID input Line 2 Control signal, when connected with Pin20, mode of analog RX performance testing	Digital Input: (2.5V<V <sub>IH</sub> <5V,0V<V <sub>IL</sub> <0.4V)

11	ACC_MAP_ID_1	Accessory ID input Line 1 Control signal, when connected with Pin20, the IP address will be set to the default address: 192.168.1.100.	Digital Input: ( $2.5V < V_{IH} < 5V, 0V < V_{IL} < 0.4V$ )
12	Squelch (Program_IO_6)	Digital Input. High level will enable opening squelch when connected with Pin20.	Digital Input ( $2.5V < V_{IH} < 5V, 0V < V_{IL} < 0.4V$ )
13	RXD	Output. Receive signal from repeater to PC	RS232 Level: -3V ~ -15V +3V ~ +15V
14	TXD	Input. Transmit signal from PC to repeater	RS232 Level: -3V ~ -15V +3V ~ +15V
15	GND	Ground	-
16	Rx_Audio	NULL	-
17	Audio_Ground	Ground	-
18	Tx_Audio	External Audio signal input	Analog input: $0V < V_{IL} < 0.5V$
19	GND	Ground	-
20	Program_IO_7	Output high level, used with Pin7 (PTT function), Pin10 (analog Rx function) and Pin11 (IP address reset function) and pin23(open squelch)	Digital Output $2.5V < V_{OH} < 3.3V$
21	Program_IO_4 (Emergency)	NULL	-
22	Program_IO_8	NULL	-

23	Program_IN_5	Digital Input High level active Opening squelch when connected with Pin20	Digital Input: (2.5V<VIH<5V,0V<VIL<0.4V)
24	Program_Out_9 (Ext_Alarm)	Reserved	-
25	Aux_Audio_Out1	NULL	-
26	Aux_Audio_Out2	NULL	-

## 4. Function and Parameter Setting

### 4.1. Conventional Functions

Conventional DMR functions:

- Supports DMR dual slot mode
- Supports DMR private call, group call and all call transfer
- Supports short Message, status message transfer
- Supports end to end voice and data encryption
- Supports GPS
- Supports interruption and monitor function
- Supports stun, activation, kill signaling transfer
- Supports IP connection
- Supports Standard AIS Interface
- Support Analog and Digital Mode
- Supports Pseudo Trunking

### 4.2. Parameter Setting

Repeater is set with default parameters when leaving the factory. Parameters such as operation frequency, channel parameters, scan and encryption may be changed according to different requirement by users. Therefore, Kirisun specially designed programmable software CPSp, which is interface-friendly, easy to operate and display-friendly, to realize the setting for repeater function parameters.

## 4.2.1. Parameters setting

Parameter settings steps are as follows

Step 1. Install the right version of the CPSP user programming software.

Step 2. Using RJ45 ethernet cable to connect the repeater with Ethernet port of computer through HUB/switchboard.

Step 3. Make sure the repeater is powered on.

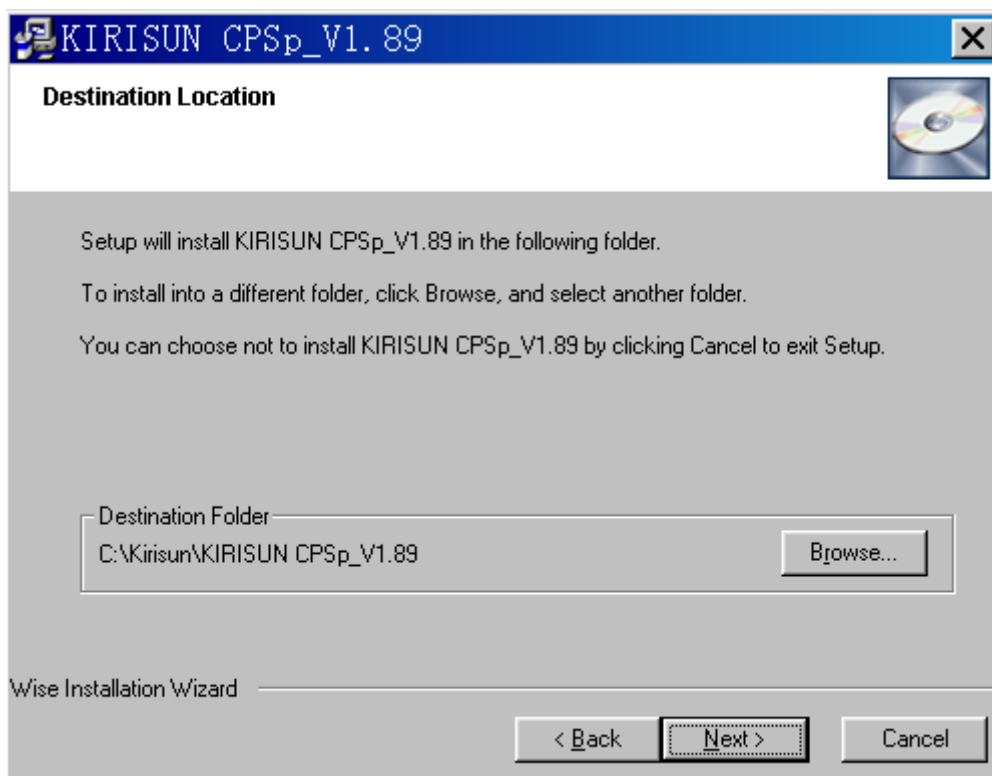
Step 4. Operate CPSP user programming software for the settings of related parameters.

The user can read parameter configuration through CPSP user programming software.

## 4.2.2. Install CPSP user programming software

Installation steps of CPSP user programming software:

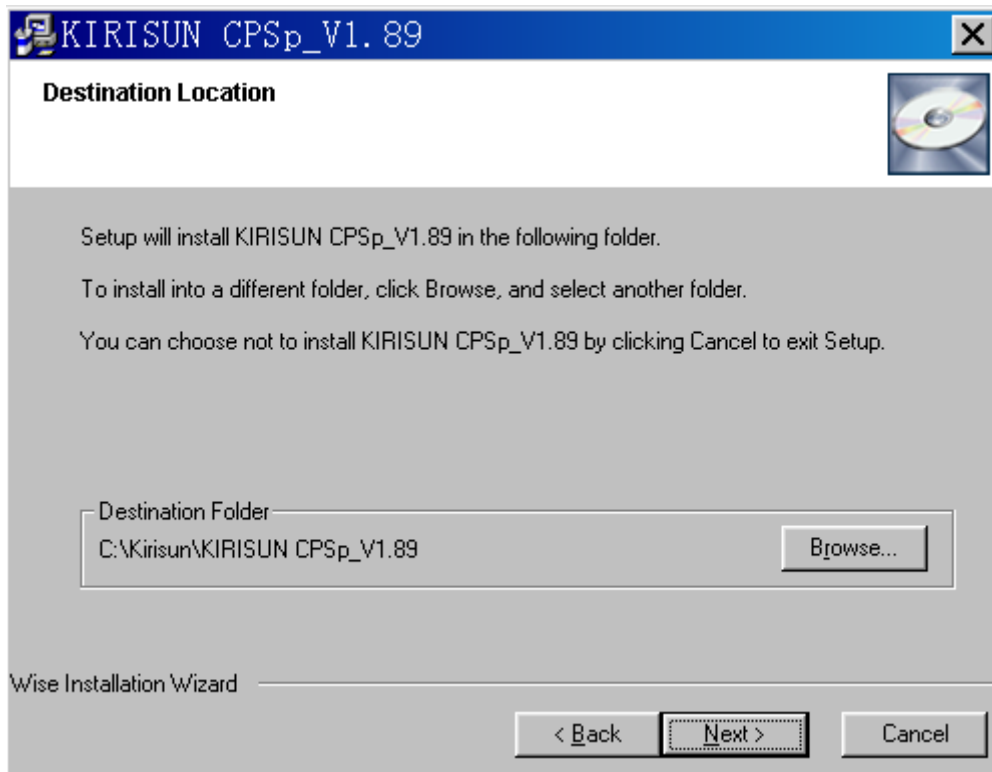
Step 1. Double click the installation file of CPSP user programming software, and the interface below will pop up.



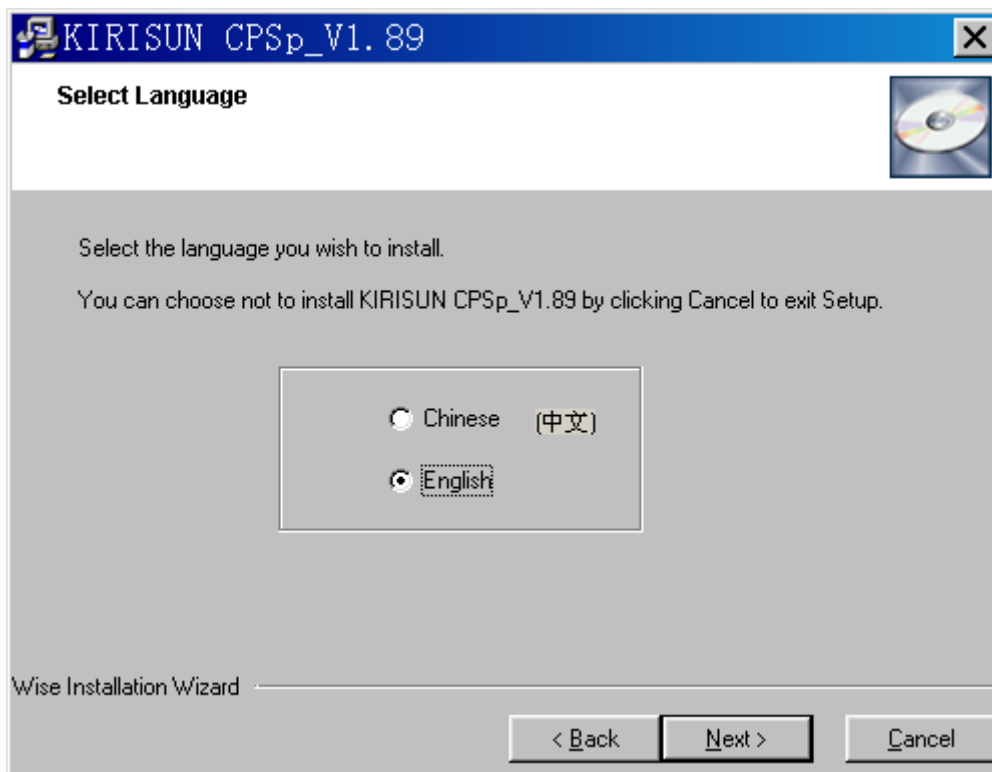
Step 2. Click "Next" and enter the next interface.

Step 3. (Option) Click browse and select the installation route.

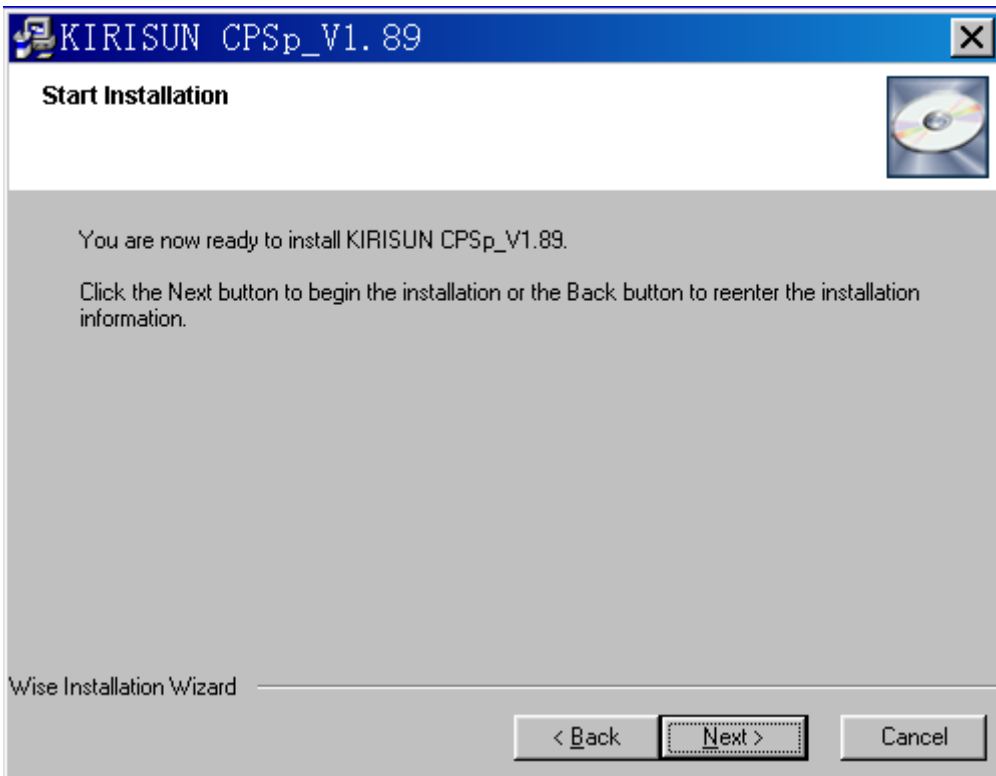
This step can be skipped if using the default route.



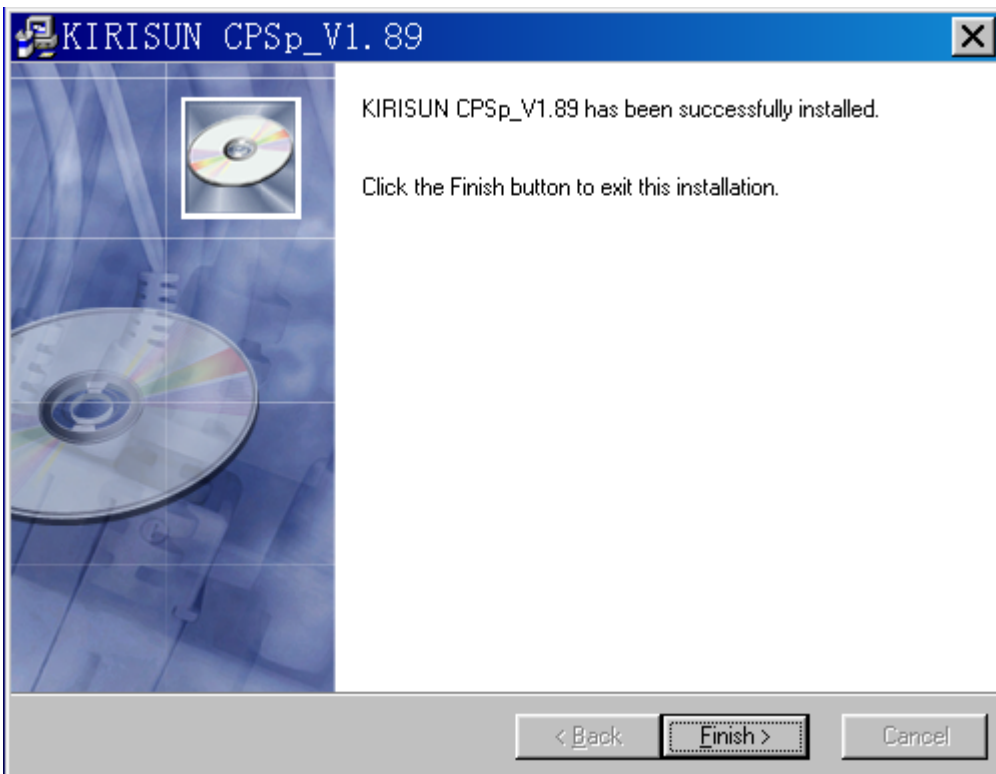
Step 4. Select the language you wish to install.



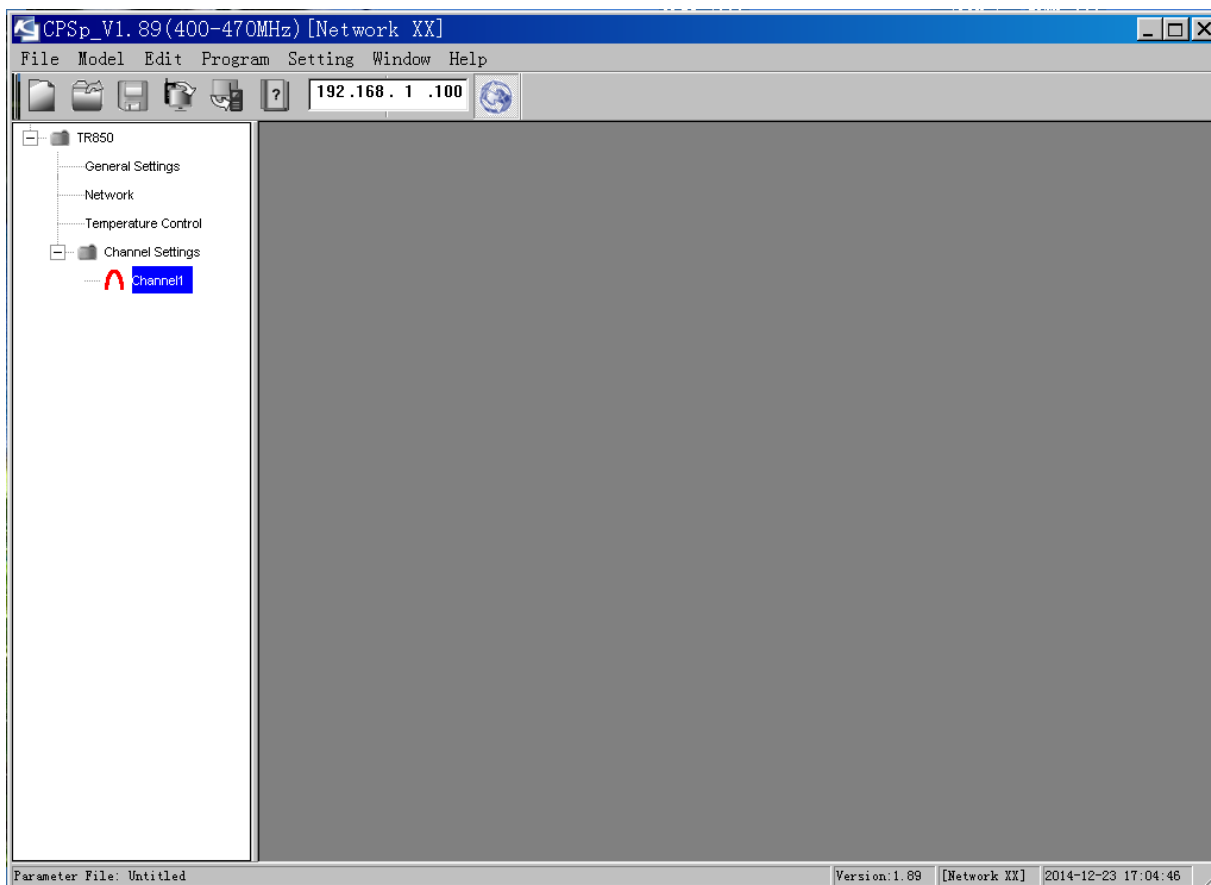
Step 5. Click "Next" and install the software.



Step 6. Click "Finish" to finish the installation.



Step 7. Please double click the CPSp user programming software to operate after acquiring authorization.  
See the figure below.



Please refer to the help file in the CPSp user programming software for more details.

**Note:**

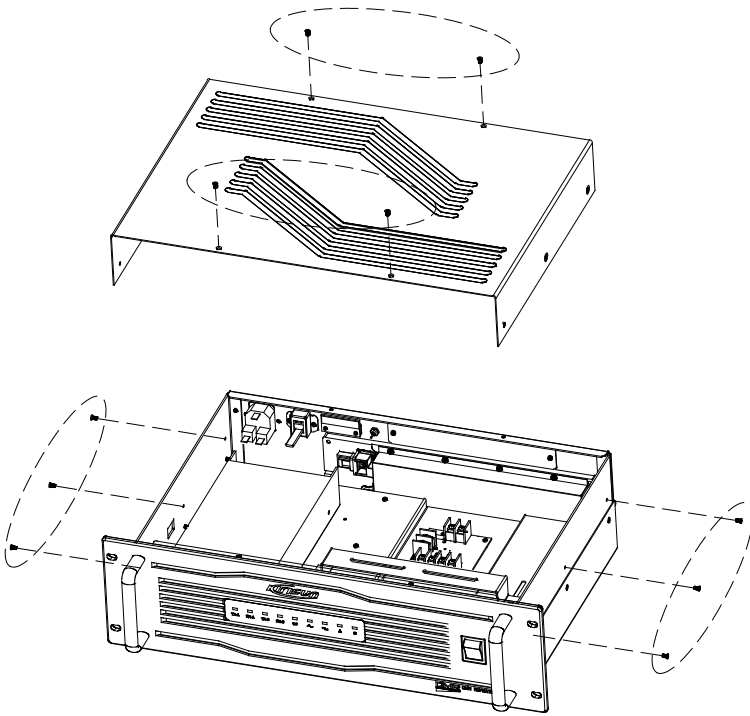
1. Errors of parameter configuration may cause malfunctions, but normally you can rewrite the correct parameter configuration.
2. Before parameter configuration modification, we strongly recommend a backup for the current parameters to make sure that the parameters can be restored after an error occurs.

## 5. Assembly and Disassembly Instruction

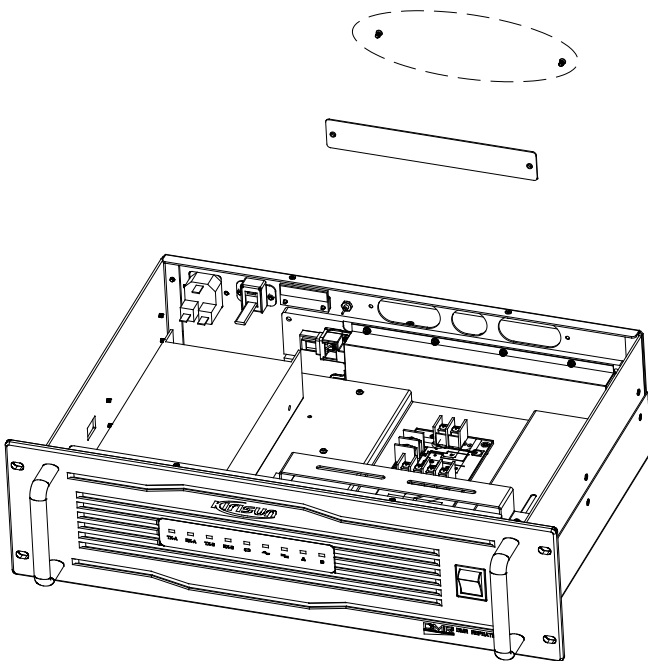
### 5.1. Duplexer Assembly

Step 1. Loosen the four screws on the top and the three screws on both sides of the top shell, and remove the shell upwards.

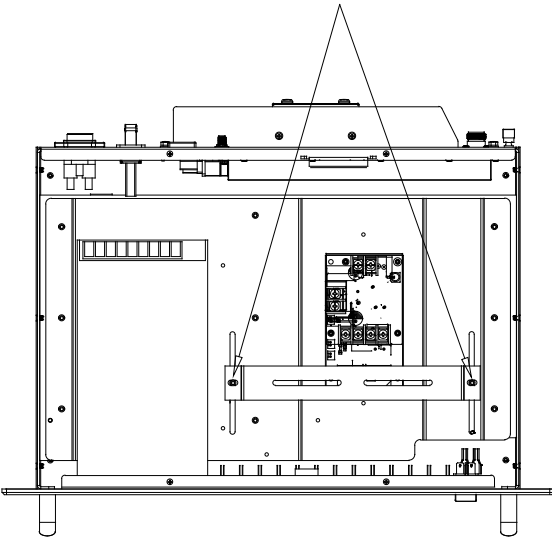




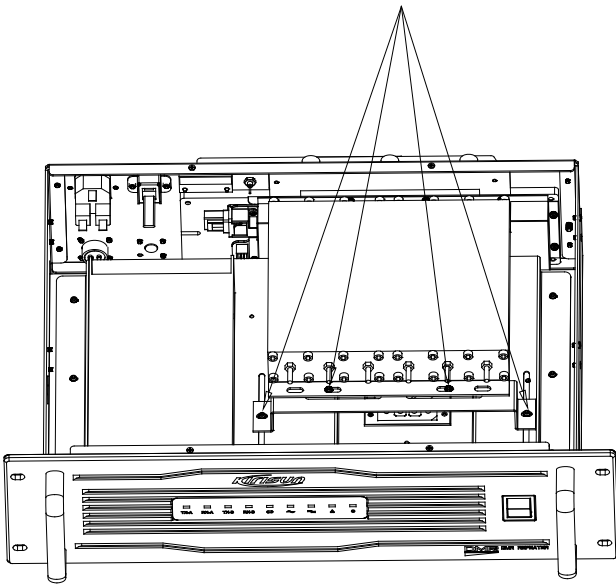
Step 2. Loosen the two screws on the duplex baffle, and remove the duplex baffle.



Step 3. Loosen the two screws which fix the duplex bracket till the bracket can be slided in the track groove.



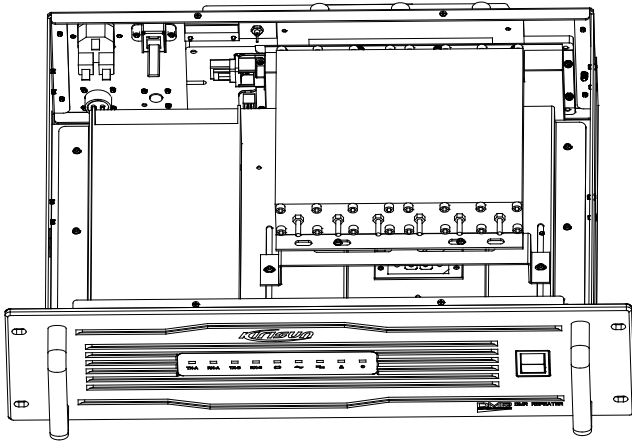
Step 4. Use screws to fix the rear part of the duplex on the bracket, and push the duplex into the box till the duplex can be properly fit into the three corresponding holes in the box before fixing the screws on the duplex bracket.



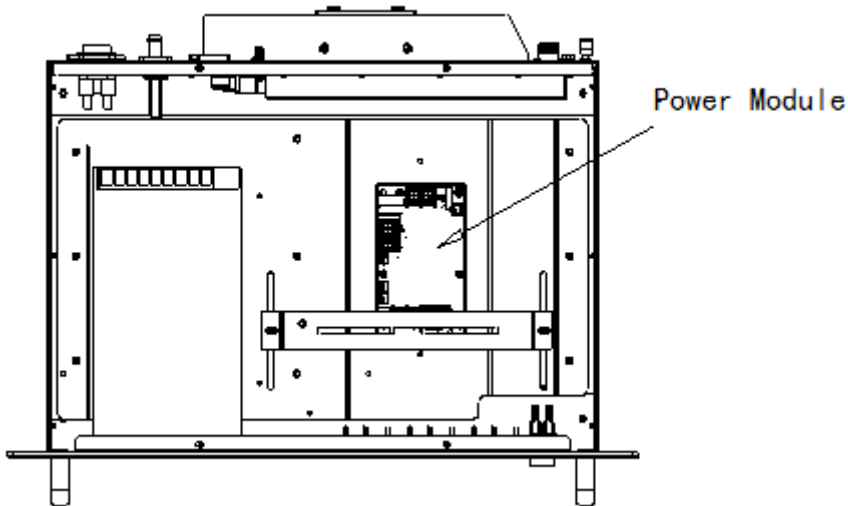
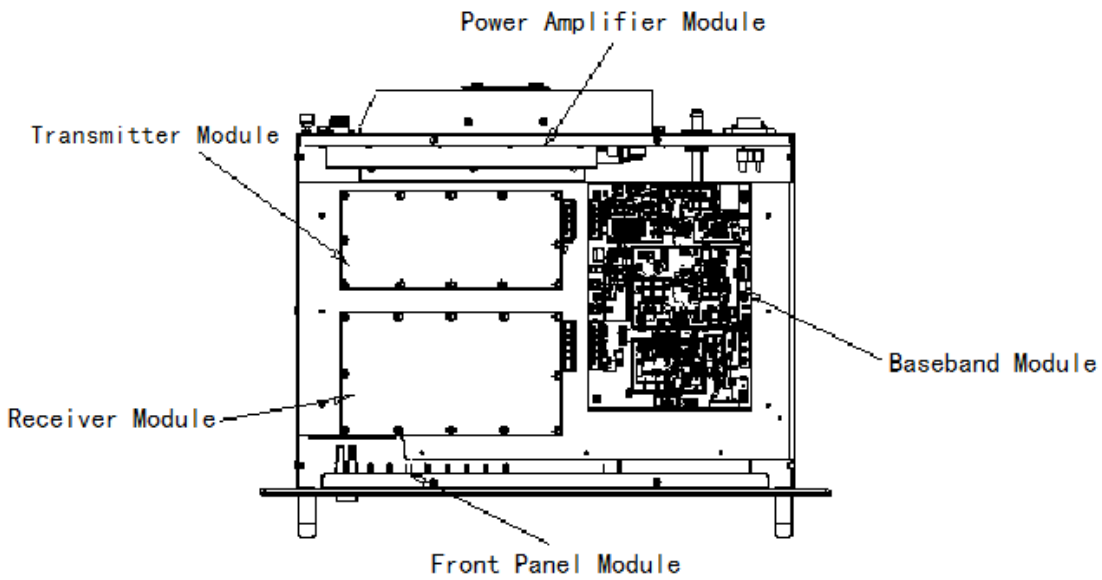
## 5.2. Disassembly Instruction

The repeater is divided into the two parts below:

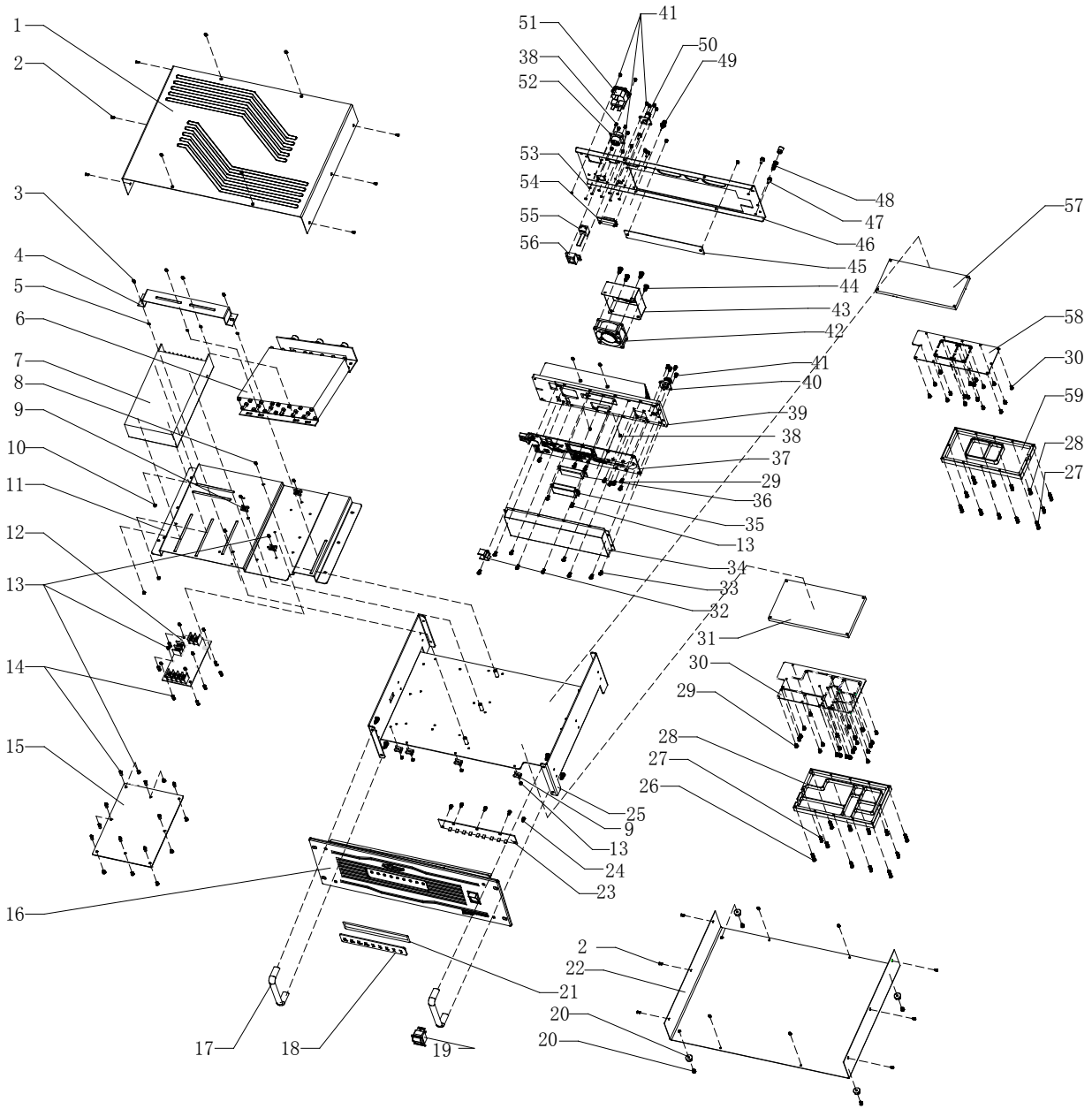
- Area allowed for users to assemble and disassemble: Internal area of the top shell. Users can assemble duplex.



- Area allowed for dealers with maintenance permit to assemble and disassemble: Internal area of the top shell and internal area of the lower shell.



### 5.3.Exploded View



No.	Part No.	Description	Quantity
1	7WOZ-4100-01A	Top panel, 1mm color zinc-plated board, dusting, with decorative stripes.	1
2	7SMF-030050M-SZC T-N1	M3*5 cross sunk machine screws. Material: stainless steel, $\phi$ 3mm*5mm cross sunk machine thread, metric coarse thread, black nickel-plated	24
3	7SAF-040080M-SZH T-N	M4*8 cross thick head combination machine screw Material: hardened iron,with flat spacer and spring	6

		spacer, pb-free.	
4	7MBF-4027-02A-X0	DR550 50W duplex bracket, zinc-plated board, 1.5mm thick, color zinc-plated, pb-free.	1
5	7NHF-040008030-N1	M4*3 hexagonal nut material: iron, internal diameter M4mm, maximum external diameter 8mm, 3mm thick, hexagonal nickel-plated nut.	6
6	Duplex, self-purchase		10
7	0ADY-4071-D	STR-U power module, SP-320-12, 12V, 320W, ROHS, with fan.	1
8	7SAF-030050M-SZY B-Z1	M3*5 cross round flat head combination machine screw. Material: hardeded iron, $\Phi$ 3mm*5mm with flat spacer and spring spacer, pb-free	10
9	3CB1-151007-B	Cable tie holder NYLON 66, 15X10X7, pb-free	10
10	7SAF-040060M-SZH T-N	M4*6 cross thick head combination machine screw.	4
11	7WOZ-4071-03A	Intermediate board 2, 1mm thick color zinc-plated board.	1
12	6SS2-4071-HWA	STR-U repeater power board jacking	1
13	7SAF-030080M-SZY B-Z1	M3*8 cross round flat head combination machine screw. Material: hardeded iron, $\Phi$ 3mm*8mm, with flat spacer and spring spacer, pb-free.	28
14	7NHC-055070306-LJ	M3*7+6 Hexagonal Copper Cylinder	19
15	6SS2-4071-HBA	STR-U/V Repeater Base Band Board Jacking	1
16	7MHF-4100-01A-W	TR850 DMR front panel, 5mm thick aluminum material, oxidized black, laser carving, with copper cylinder	1
17	7MHP-4071-01-W0	Handle, aluminum, oxidized black	2
18	7MBP-4100-01A-W	TR850 lens 2mmthick, PMMA, transparent, screen printing	1

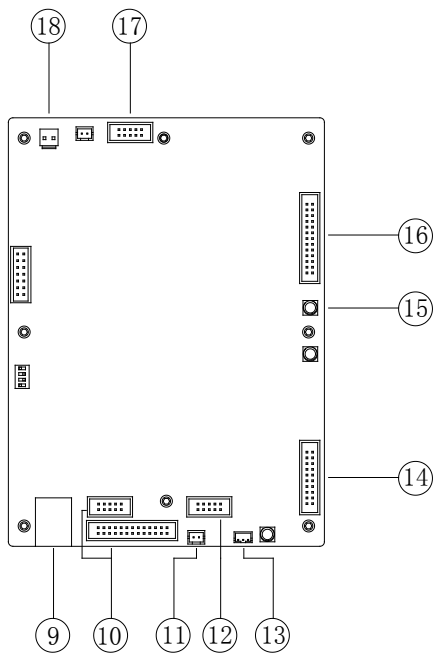
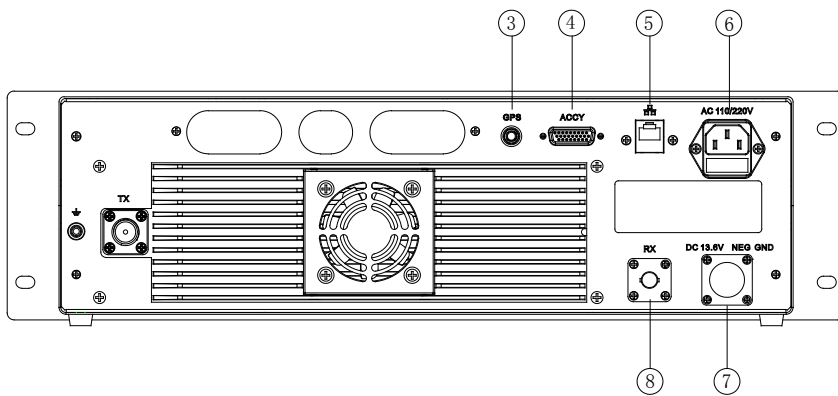
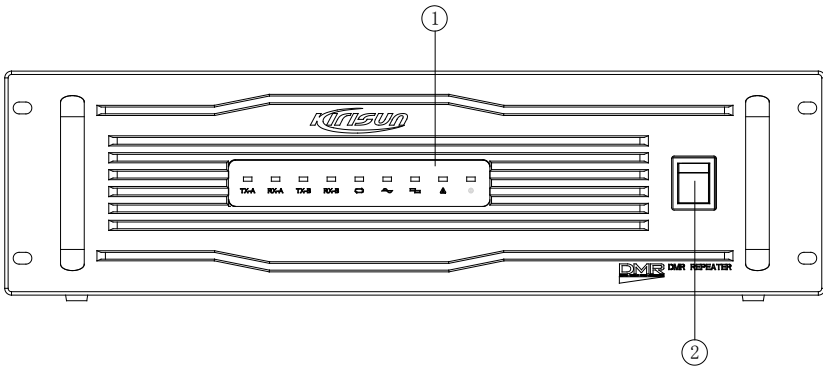
19	3SB3-YB-S1-Q	AC power switch.	1
20	7GCR-4071-01A-W0	Repeater foot pad (4 pieces) silica gel, with screws (4 pieces)	1
21	7GCJ-S4071-J	STR-U lens double side tape, NITTO 57120B double side tape, pb-free	1
22	7WOZ-4100-02A	Down panel, 1mm thick color zinc-plated board, dusting.	1
23	6SS2-4071-HFB	STR-U/V repeater front panel jacking	1
24	7SMF-030050M-SZY B-N	M3*5 cross round flat head machine screw  Material: hardened iron, $\Phi$ 3mm*5mm cross round flat head nickel-plated machine thread, metric coarse thread	5
25	7WOZ-4071-02A	Intermediate boardm 1, 2mm thick color zinc-plated board, rivet screw column	1
26	7SMF-030250M-SZC T-N1	M3*25 cross sunk machine screw  metric coarse thread, white nickel-plated	8
27	7SMF-030180M-SZC T-N1	M3*18 cross sunk machine screw  metric coarse thread, white nickel-plated	16
28	7MHL-4071-03A-W	STR-U receive module aluminium shield down case  Aluminum	1
29	7SMF-030060M-SZY B-N	M3*6 cross round flat head machine screw  Material: hardeded iron, $\Phi$ 3mm*6mm metric coarse thread	61
30	6SS2-4067-HRB	DR650-02receiving board jacking	1
31	7MHL-4071-02A-W	STR-U receive module aluminium shield down case  Aluminum	1
32	3CB1-004071-A	STR-U Power Amplifier Board fixed socket processed with aluminum alloy	1

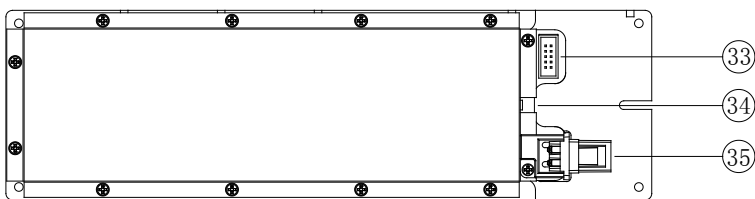
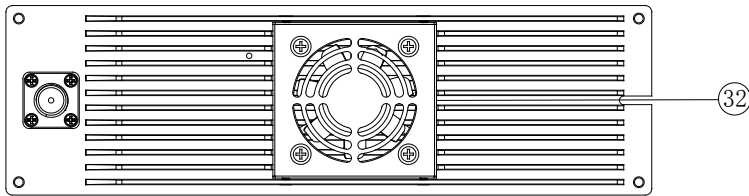
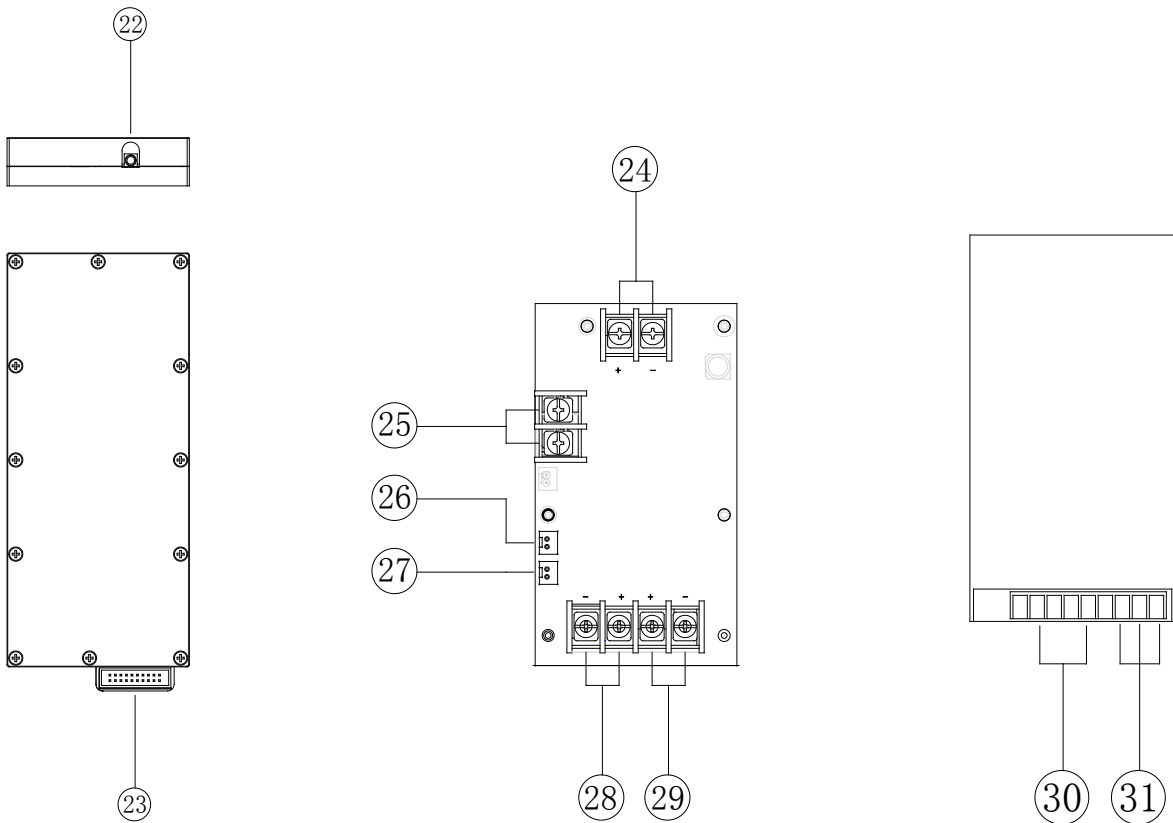
33	7SAF-030050M-SZY B-Z1	M3*5 cross round flat head machine screw  Material: hardened iron, with flat spacer and spring spacer, pb-free.	10
34	7MBC-4071-01A-W	STR-U power amplifier module big shield cover , stainless steel, 0.5mm thick	1
35	7MMC-1943-01A-N	PT8200 power module shield cover; pb-free	1
36	1MR3-RA55H4047M	UHF RF amplifier IC 8200-02, DR550H STU	1
37	6SS2-4071-HPC	STR-U power amplifier jacking (130722)	1
38	7SMF-030060M-SZC T-N1	M3*6 cross sunk machine screw  Material: hardened iron, $\phi$ 3mm*6mm cross sunk machine thread, metric coarse thread, black nickel-plated.	8
39	7MHL-4071-01A-W	STR-U radiator; processed with aluminum alloy	1
40	3CR7-N-KKF1	RF connector	1
41	7SMF-030100M-SZC T-N1	M3*10 cross sunk machine screw  Material: hardened iron, $\phi$ 3mm*10mm cross sunk machine thread, metric coarse thread, black nickel-plated.	12
42	4MF7-DFB602512H M	Fan DFB602512HM, Specification: 12V/0.3A, 60X60X25mm	1
43	7MHF-4027-02A-Z	DR550 Fan-fixing bracket, zinc-plated board, 0.8mm thick , black dusting on surface	1
44	7STF-050120A-SZHT -N	M5*12 cross thick head self-tapping screws. Hardened iron	4
45	7WOZ-4100-04A	Duplex baffle 1mm, thick color zinc-plated board, dusting	1
46	7WOZ-4100-03A	Rear panel (part no. cancelled) 1.5mm thick color zinc-plated board, dusting	1
47	7SAF-040100M-SZLJ	M4*10 Cross external hexagonal combination	4

	-Z1	machine screw. Material: hardened iron	
48	7MHS-4027-06A-W	M4*8 grounding screw; stainless steel, M4.0*8	1
49	3CR7-SMA-160	RF coaxial line-1 SMA-C-KY1.5-1 to SMA-C-JW1.5, type: RG141A/U, line length 160mm	1
50	3CR7-BNC-440	BNCcoaxial line SMA-C-J1.5 to BNC(rectangular flange plate 24*24),RG141A/U, line length: 440mm	1
51	3CP3-YB-B2-Q1	Power socket, 2.5A T 20mm HRC 250V type	1
52	3WPC-WS20K2Z	Two core aviation socket, WS20K2Z	1
53	7NHF-030062025-Z1	M3*2.5 hexagonal nut. Material: iron, internal diameter M3mm, maximum external diameter 6.2mm, 2.5mm thick, hexagonal and zinc-plated, metric coarse thread.	10
54	6SS2-4071-HL1A	STR-U repeater accessory board plug-in material	1
55	3WPC-812028-A	STR-U Network port connecting wire 8pin, wire length 120mm, 28AWG, with network port and crystal head.	1
56	7WOZ-4100-05A	Network port baffle, 1mm thick color zinc-plated board	1
57	7MHL-4071-04A-W	STR-U Tx module aluminum alloy shield bottom cover	1
58	6SS2-4067-HTB	DR650-02 Tx module jacking DR650-02 Tx module jacking, pb-free	1
59	7MHL-4071-05A-WA	STR-U Tx module aluminum alloy shield up cover	1



## 5.4.Connection





Part no.	Description	Connect mode
3WPD-S4071-A	Power connecting line-1 3 Pin, 135mm long, wire size 16AWG. one end with cold-press sockets terminal, one end round terminal.	6—31
3WPD-S4071-B	Power connecting line-2, 2Pin, red length 950mm long, black wire 415mm, wire size 12AWG, both ends with two round terminals.	28—30

3WPD-S4071-C	Power connecting line -3 2Pin, 665mm long, wire size 12AWG	7—29
3WPD-S4071-D	Power connecting line -4 2Pin, 315mm long, wire size 12AWG. One end with two round terminals, and the other a base.	24—35
3WPD-S4071-E	Power connecting line-5 2pin, 575mm long, wire size 18AWG, 3.96 interval, with socket and round terminal.	18—25
3WPD-S4071-F	Power connecting line-6 2pin, wire length 550mm, wire size 20AWG, interval 2.54, with socket and cold-press sockets terminal	2—26
3CR7-SMA-160	RF coaxial wire-1 SMA-C-KY1.5-1 to SMA-C-JW1.5, wire type: RG141A/U, wire length 160mm	3—13
3CR7-SMA-110A	RF coaxial wire -2 SMA-C-J1.5 to SMA-C-JW1.5, wire type: RG141A/U, wire length 110mm	15—21
3CR7-BNC-440	BNC coaxial wire, SMA-C-J1.5 to BNC(rectangular flange plate 24*24), RG141A/U, wire length: 440mm	8—20
3WPC-812028-A	STR-U internet port connecting wire 8pin, wire length 120mm, 28AWG, with internet port and crystal head,	5—9
3WPT-P26050PH25420P	With dual-plugged flat cable AWG26#, 2.54 interval, wire length 50mm, 20P socket, dual-headed socket	14—23
3WPT-P26050PH25426P	With dual-plugged flat cable AWG26#, 2.54 interval, double flat cable, wire length 50mm, 26Psocket, dual-headed socket	16—19
3WPD-S4071-G	Power connecting line-7 2pin, wire length 350mm, wire size 20AWG, 2.54 interval, with socket and cold-press sockets terminal	2—27
3CR7-SMA-350	RF coaxial wire -3 SMA-C-JW1.5 to SMA-C-JW1.5, wire type:RG141A/U, wier length 350mm	22—34
3WPT-P26155PH25426P	With three-plugged flat cable, AWG26#, 2.54 interval, three flat cable, 155mm long	4—10

3WPT-P26350PH25410P	With dual-plugged flat cable, AWG26#, 2.54 interval, double flat cable, wire length 350mm, 10P socket.	1—12
3WPT-P26080PH25410P	With dual-plugged flat cable, AWG26#, 2.54 interval, double flat cable, wire length 80mm, 10P socket, double-headed socket.	17—33
3WPD-160140-1PIN	Connected to ground wire 1Pin, blue wire, 140mm length, wire size, 16AWG.; two ends with round terminal	31(ground terminal)— machine case
Fan wire	Come with fan	11—32

## 6. Adjustment

During maintenance, the repeater may need some testing and modulation for technical index after changing the components.

### 6.1. Preparation

Please prepare the tools and equipment before testing the DMR repeater:

- Integrated tester
- PC and CPSP software
- AEROFLEX 3920
- Spectrum analyzer FSU
- Antenna interface converter
- Universal interface

### 6.2. Method of Modulation and Test

#### 6.2.1. Local Oscillator Adjustment

Subject	Test Point	Test Procedure	Standard
12.8M Clock	base band board J6	<ol style="list-style-type: none"> <li>1. Enter test mode "12.8M Clock".</li> <li>2. Set HP8921 to TX mode; connect the reference frequency port to HP8921 RF high power input port.</li> <li>3. Enter computer modulation mode.</li> </ol>	$\leq \pm 1\text{Hz}$

		4. Adjust to $12.8\text{MHz} \pm 1\text{Hz}$ .	
Rx localoscillator power	Rx board test point TP3005	<ol style="list-style-type: none"> <li>1. Enter test mode "Receiver BPF".</li> <li>2. Set HP8921 to TX mode.</li> <li>3. Connect the TP3005 test point on the RX board to HP8921RF high power input port.</li> <li>4. Check the frequency: (Rx frequency <math>-51.65\text{MHz}) \pm 100\text{Hz}</math>; output power <math>&gt; 10\text{dBm}</math>.</li> </ol>	<p>Frequency tolerance <math>\leq \pm 200\text{Hz}</math></p> <p>Output power <math>&gt; 10\text{dBm}</math></p>
Tx central frequency & power	Tx module J200	<ol style="list-style-type: none"> <li>1. Enter test mode "Low Freq.Mod Deviation".</li> <li>2. Set HP8921 to TX mode.</li> <li>3. Connect Tx module RF output to HP8921 RF high power input port.</li> <li>4. Adjust to <math>\pm 100\text{Hz}</math>, Check: output power <math>&gt; 15\text{dBm}</math>.</li> </ol>	<p>Frequency tolerance <math>\leq \pm 200\text{Hz}</math></p> <p>Output power <math>&gt; 15\text{dBm}</math></p>
Tx lock voltage testing	Tx board TP100	<ol style="list-style-type: none"> <li>1. Turn on the repeater.</li> <li>2. Set HP8921 to TX mode.</li> <li>3. Connect TX port to HP8921 RF high power input port.</li> <li>4. Enter computer modulation mode.</li> <li>5. Click Tx low power test points to test lock voltage</li> </ol>	$0.5\text{V} \leq \text{CV voltage} \leq 4.5\text{V}$
Rx lock voltage test	Rx board TP100	<ol style="list-style-type: none"> <li>1. Turn on the repeater.</li> <li>2. Set HP8921 to TX mode.</li> <li>3. Connect TX port to HP8921 RF high power input port</li> <li>4. Enter computer modulation mode.</li> <li>5. Click Rx sensitivity test points to test lock voltage</li> </ol>	$0.5\text{V} \leq \text{CV voltage} \leq 4.5\text{V}$

## 6.2.2. Tx Adjustment

Subject	Modulation Procedure	Standard
Tx high power	<ol style="list-style-type: none"> <li>1. Enter pc tuning mode.</li> <li>2. Enter modulation mode "High Power".</li> <li>3. Adjust PC software value; observe power value on the integrated tester.</li> <li>4. Adjust to test power: <math>40 \pm 2\text{W}</math>.</li> <li>5. Modulate the frequency one by one.</li> </ol>	$40 \pm 5\text{W}$
Tx low power	<ol style="list-style-type: none"> <li>1. Enter computer modulation mode.</li> <li>2. Enter modulation mode "Low Power".</li> <li>3. Adjust PC software value; observe power value on the</li> </ol>	$20\text{W} \pm 1.5\text{db}$

	<p>integrated tester.</p> <p>4. Adjust to test power: 20W.</p> <p>5. Modulate the frequency one by one.</p>	
Low frequency modulation frequency deviation	<p>1. Enter computer modulation mode.</p> <p>2. Click frequency F1 to F6.</p> <p>3. When AF Freq is 0.1kHz, observe FM Deviation on the integrated tester, and modulate PC software value.</p> <p>4. Adjust FM Deviation to <math>5.0 \pm 0.05\text{kHz}</math>.</p> <p>5. Click "ok" to save.</p>	4.95kHz-5.05kHz
High frequency modulation frequency deviation	<p>1. Enter computer modulation mode.</p> <p>2. Click Frequency F1 to F6.</p> <p>3. When AF Freq is 6.0 kHz, observe FM Deviation on the integrated tester, and modulate PC software value.</p> <p>4. modulate FM Deviation to <math>5.0 \pm 0.05\text{kHz}</math>.</p> <p>5. Click "ok" to save.</p>	4.95kHz-5.05kHz
4FSK EER test	<p>1. Enter computer modulation mode.</p> <p>2. Modulate PC software value to make repeater transmit 0.153.</p> <p>3. Check 4FSK EER <math>\leq 5\%</math>.</p> <p>4. Modulate frequencies one by one.</p> <p>5. Observe FSK EER value on the integrated tester.</p> <p>6. Check 4FSK EER <math>\leq 5\%</math>.</p>	FSK EER $\leq 5\%$
Maximum audio frequency deviation test.	<p>1. Connect the audio input wire to repeater.</p> <p>2. Output audio signal 1KHz RMS 120mV to repeater and make it transmit.</p> <p>3. The audio frequency deviation should be: N: <math>2000 \pm 100\text{Hz}</math>, W: <math>4000 \pm 100\text{Hz}</math>.</p> <p>4. Test frequencies one by one.</p>	N: $2000 \pm 200\text{Hz}$ W: $4000 \pm 400\text{Hz}$
QT/DQT frequency deviation and wave form test.	<p>1. Observe frequency deviation of QT.</p> <p>2. Observe frequency deviation and wave form of DQT.</p>	N: $350 \pm 150\text{Hz}$ W: $750 \pm 250\text{Hz}$
Modulation distortion	Observe distortion form value.	$< 3\%$
Tx SNR	Observe SNR form value	W: $> 45\text{dB}$ N: $> 40\text{dB}$

Analog&digital ACP	Observe ACP display value.	W: <-70dB N: <-60dB
Spurious emission	Observe spectrum analyzer display value.	<1GHz: <-36dBm >1GHz: <-30dBm

### 6.2.3. Rx Adjustment

Modulation Subject	Modulation Procedure	Standard
Rx Sensitivity	<ol style="list-style-type: none"> <li>1. Enter computer modulation mode.</li> <li>2. Enter modulation mode "Receiver BPF", and click the six frequencies one by one.</li> <li>3. Make SINA &gt; 12dB.</li> <li>4. Set the four Rx frequencies as -25.825MHz(*1、*2、*3、*4), and signal strength as -40dBm; the SINA should be &lt; 7dB.</li> </ol>	-
Narrow band squelch level 9 on	<ol style="list-style-type: none"> <li>1. Enter computer modulation mode</li> <li>2. Set the channel to the current modulation frequency.</li> <li>3. Enter modulation mode "SQL9 Open (N)", and click "start", and change to the next frequency after the value is stable.</li> <li>4. Modulate the frequency of narrow band and wide band in turn.</li> </ol>	-
Narrow band squelch level 9 off	<ol style="list-style-type: none"> <li>1. Enter computer modulation mode.</li> <li>2. Set the channel to the current modulation mode.</li> <li>3. Enter the modulation mode "SQL9 Close(N)", and click "start", and change to the next frequency after the value is stable.</li> <li>4. Modulate the frequency of narrow band and wide band in turn.</li> </ol>	-

Narrow band squelch level 1 on	<ol style="list-style-type: none"> <li>1. Enter computer modulation.</li> <li>2. Set the channel to the current modulation mode.</li> <li>3. Enter the modulation mode "SQL1 Open(N)", and click "start", and change to the next frequency after the value is stable.</li> <li>4. Modulate the frequency of narrow band and wide band in turn.</li> </ol>	-
Narrow band squelch level 1 off	<ol style="list-style-type: none"> <li>1. Enter computer modulation.</li> <li>2. Set the channel to the current modulation mode.</li> <li>3. Enter the modulation mode "SQL1 Close(N)", and click "start", and change to the next frequency after the value is stable.</li> <li>4. Modulate the frequency of narrow band and wide band in turn.</li> </ol>	-
Wide band squelch level 9 on	<ol style="list-style-type: none"> <li>1. Enter computer modulation mode.</li> <li>2. Set the channel to the current modulation mode.</li> <li>3. Enter the modulation mode "SQL9 Open(W)", and click "start", and change to the next frequency after the value is stable.</li> <li>4. Modulate the frequency of narrow band and wide band in turn.</li> </ol>	-
Wide band squelch level 9 off	<ol style="list-style-type: none"> <li>1. Enter computer modulation mode.</li> <li>2. Set the channel to the current modulation mode,</li> <li>3. Enter modulation mode "SQL9 Close(W)", and click "start", and change to the next frequency after the value is stable.</li> <li>4. Modulate the frequency of narrow band and wide band in turn.</li> </ol>	-
Wide band squelch level 1 on	<ol style="list-style-type: none"> <li>1. Enter the computer modulation mode.</li> <li>2. Set the channel to the current modulation mode.</li> <li>3. Enter the modulation mode "SQL1 Close(N)", and click "start", and change to the next frequency after the value is stable.</li> <li>4. Modulate the frequency of narrow band and wide band in turn.</li> </ol>	-
Wide band squelch level 1 off	<ol style="list-style-type: none"> <li>1. Enter the the computer modulation mode.</li> <li>2. Set the channel to the current modulation mode,</li> <li>3. Enter the modulation mode "SQL1 Close(N)", and click "start", and change to the next frequency after the value is stable.</li> <li>4. Modulate the frequency of narrow band and wide band in turn.</li> </ol>	-



Rx distortion	Observe the distortion value,	<3%
Rx SNR	Observe SNR value	W: >45dB N: >40dB
CTCSS/CDC SS	-	Can transmit
BER Test	1. Set the output range of 3920 as -118dBm. 2. Enter BER test mode. 3. Click "Start", and observe BER.	EER≤5%

## 7. Main Technical Functions and Specifications

<b>General Specification</b>	
<b>Frequency Range</b>	UHF: 400-470MHz VHF:136-174MHz
<b>Channel Capacity</b>	16
<b>Channel Spacing</b>	12.5kHz/20kHz/25kHz
<b>Weight</b>	11.5kg
<b>Dimension(H*B*D)</b>	138mm*62mm*38mm
<b>Environment Index</b>	
<b>Operating Temperature</b>	-30℃~+60℃
<b>Storage Temperature</b>	-40℃~+85℃
<b>Rx Parameter</b>	
<b>Frequency Stability</b>	±1.5ppm
<b>Analog Rx Sensitivity</b>	-118dBm(12dB)/-121dBm(12dB)
<b>Digital Rx Sensitivity</b>	-120dBm(5%)
<b>Intermodulation</b>	ETSI: 70dB TIA603: 75dB

<b>Adjacent Channel Selectivity</b>	ETSI/TIA603: 60dB@12.5kHz, 70dB @20/25kHz
<b>Spurious Response Rejection</b>	ETSI/TIA603: 70dB
<b>Conducted Spurious Emission</b>	-57dBm
<b>Impedance</b>	ETSI: 84dB    TIA603: 80dB
<b>Rated Audio Distortion</b>	<3%
<b>Hum and noise</b>	-40dB@12.5kHz/-43dB@20kHz/-45dB@25kHz
<b>Audio Response</b>	+1dB ~ -3dB
<b>Tx Parameter</b>	
<b>Frequency Stability</b>	$\pm 1.5$ ppm
<b>Tx Power</b>	Low: 25W, high: 40W
<b>Hum and noise</b>	-40dB@12.5kHz/-43dB@20kHz/-45dB@25kHz
<b>Conducted Radiated Emission</b>	-36dBm@<1GHz, -30dBm@>1GHz
<b>Adjacent Channel Power</b>	60dB@12.5kHz, 70dB @20/25kHz
<b>FM Modulation</b>	11K0F3E @12.5kHz, 14K0F3E @20kHz, 16K0F3E @25kHz
<b>4FSK Modulation</b>	12.5kHz(Only data): 7K60FXD 12.5kHz(data+speech): 7K60FXE
<b>Modulation Limiting</b>	$\pm 2.5$ kHz@12.5kHz, $\pm 4$ kHz@20kHz, $\pm 5$ kHz@25kHz
<b>Audio Response</b>	+1dB~-3dB
<b>Audio Distortion</b>	3%
<b>Vocoder</b>	AMBE++

<b>Digital Protocol</b>	ETSI TS 102 361-1, -2, -3
<b>GPS Index</b>	
<b>TTF(cold start)Time to First Fix</b>	<1 minute
<b>TTF(hot start)Time to First Fix</b>	<10 seconds
<b>Horizontal Accuracy</b>	<10 meters

## 8. Maintenance and Test Equipment

<b>Equipment</b>	<b>Major Specification</b>
RF Signal Generator	Frequency Range: 10MHz~3GHz Modulation: frequency modulation and external modulation. Output: $-127\text{dBm}/0.1\mu\text{V}$ - $> -47\text{dBm}/1\text{mV}$
Power meter	Input Impedance: $50\Omega$ Operating Frequency: 100MHz~1000MHz Measurement Range: about 10W
Deviation Meter	Frequency Range: 100MHz~1000MHz
DVM	Measurement Range: DC 10mV~20V Input Impedance: minimum circuit load high input impedance
Oscilloscope	30 ~100MHz
High Sensitivity Frequency Counter	Frequency Range: 100 ~1000MHz Frequency Stabilization : 0.2ppm or lower
Ammeter	5A
Audio voltmeter	Measurement Range: 50Hz~10KHz Voltage Range: 1mV~10V

Audio Generator	Measurement Range: 50Hz~5KHz or higher Output: 0~1V
Spectrum Tester	Capacity: 3% or lower at 1KHz Input Level: 50mV~10Vms
Spectrum Analyzer	Measurement Range: 100~3GHz or higher
5 $\Omega$ dummy load	100W
Voltage Stabilization Power Supply	Output Voltage: 5V~30V; Current: 20A
Integrated Tester	HP8921, IFR3920

## 9. Troubleshooting

No.	Problems	Causes and Solution
1	Short coverage	<ol style="list-style-type: none"> <li>1. Check the duplexer isolation, and whether the insertion loss meets the requirement.</li> <li>2. Check if there is any feeder connecting damage or abnormality.</li> <li>3. Check if the antenna frequency range matches with the repeater, and check if the antenna is broken.</li> <li>4. Check if there is high power radio antenna beside the repeater</li> </ol>
2	Unable to repeat	<ol style="list-style-type: none"> <li>1. Check if the settings such as terminal frequency, CTCSS, CDCSS, color code, repeater slot are correct.</li> <li>2. Check if there is interference on the uplink frequency.</li> <li>3. Beyond the communication scope.</li> </ol>
3	Unable to receive	<ol style="list-style-type: none"> <li>1. Bad antenna contact. Please fix the antenna tightly.</li> <li>2. Inconsistent frequency between Tx and Rx. Please select the same frequency.</li> <li>3. Beyond the communication scope.</li> </ol>
4	Rx green light is on without being able to repeat	Check if the settings such as terminal frequency, CTCSS, CDCSS, color code, repeater slot are correct.

5	GPS cannot locate.	<ol style="list-style-type: none"> <li>1. Check if the GPS settings are right. If not, Please reset it.</li> <li>2. The antenna may be put in a close place, please put it in a open place and relocate.</li> </ol>
6	LED lights fail to lightup on the the front panel.	<ol style="list-style-type: none"> <li>1. Check 13.6VDC input or 100-220VAC input and the connector status on the power board.</li> <li>2. Check the protective tube inside the socket if it is AC input.</li> <li>3. Check the baseband board input voltage 13.6V and 3V3_OMAP indicator light (LED6).</li> <li>4. Check the status of front board interface and the flat cable.</li> </ol>
7	Fails to be powered on.	<ol style="list-style-type: none"> <li>1. Check the power indicator on the front panel.</li> <li>2. Check 13.6VDC input or 100-220VAC.</li> <li>3. Check the baseband board input voltage 13.6V and 3V3_OMAP indicator (LED6).</li> <li>4. Check the DIP switch (J4) code location on the side of baseband board, and it should be in the start mode normally (1, 2, 3, off).</li> <li>5. Check the baseband board OMAP 24M clock(Y2).</li> <li>6. Connect the serial port (J23), and check the programming printing information. Chec k if the program is loaded successfully based on the print information and if the chip is initialized correctly.</li> </ol>
8	The lights on the baseband fail to light up.	Check if the DC input port voltage is 13.2V, check whether DCDC (U1) input is 13.2V if the voltage is right, if not, please change the fuse F1. Or check if U1 output is 5V, if not, check U1 periphery or change U1. Or check PMU (U2) or change U2.
9	The alarm red light is on or blinking on the front panel after powering on.	<ol style="list-style-type: none"> <li>1. Check the flat cable between Tx module and Rx module.</li> <li>2. Check Tx module interface (J17) and Rx module interface(J15).</li> <li>3. Check if the baseband board 12.8MHz clock output interface (J6 or J7) is normal.</li> </ol>
10	FPGA operating LED is abnormal.	<ol style="list-style-type: none"> <li>1. Check the status of the four lights (LED2, LED3, LED4, LED5) beside the baseband board FPGA (U14), and check the operating status of OMAP and FPGA. Normally, 20 seconds after powering on, LED3 lights up, and LED2 and LED4 blinks simultaneously, indicating the program is loaded successfully from NAND; after another 40 seconds, LED3 and LED4 Lights up, and LED2and LED5 blinks simultaneously, indicating CPU and FPGA are started. If the program keeps failing on loading or starting, please connect to the JTAG port (J2) to connect to the OMAP simulator inspection program or reburn the program. If the burning</li> </ol>

		<p>programming cannot be completed, changing NAND FLASH (U7) for a second modulation and changing the parameter settings is suggested.</p> <p>2. Check the DC power supply of the processor unit below: 3V3_OMAP 1V2_OMAP 1V8_DDR</p> <p>3. Check the DC power supply of the FPGA unit below. VCCINT(1.2V) VCCD_PLL(1.2V) VCCA(2.5V) VCCIO(3.3V)</p> <p>4. Check the baseband board 12.8M clock (Y5) and 24M clock(Y2).</p>
11	Network connection Fails	<p>1. Check the cable connecting status.</p> <p>2. Check the internet card chip power.</p> <p>3. Check the 50M clock of the internet card chip.</p>
12	No voice repeated	<p>Please check Pin2 of transmit unit connector (J17). If there is no modulation signal, please check reference voltage VREF (2.048V) of DAC output from U29. If the VREF voltage is abnormal, please change U29. If VREF is normal, please check DAC (U24).</p>
13	No voice outside the mode.	<p>1. Check the connecting status of ACCY connecting cable and connector (U9).</p> <p>2. Check the 18.432MHz clock of CODEC and power of 3VE_A, 3V3_OMAP. Please input 1KHz and 50mV testing audio signal on the TXAF test point of baseband board, and check the transmitting deviation from Comprehensive test instrument. If the deviation is abnormal, please change CODEC chip (U30).</p>
14	Abnormal Programming	<p>1. Check the connecting status of network connector (J12) and network cable.</p> <p>2. Check the network card running status of PC.</p> <p>3. Check 50M clock(J23) of network connector on baseband.</p> <p>4. Check prompt content on the programming running print information and make the corresponding judgment.</p>

# Appendix1 400-470MHz UHF Band Spare Part List

## Table1 Parts List (Rx Module Section)

Part No.	Accessory Name	Description	Quantity	Location
6PM7-4067-HRB	DR650-02 Rx board	DR650-02-RX-130304.PC B, 4 layers, 1.6MM thickness, 194X90mm, FR-4, no frequency distinction	1	
3FW1-42932-302320	R fuse	429003/433003/466003, 3216, 3A/32V	1	CB5000
5FT1-LTWC450G	E ceramic filter	LTWC450G	1	CF3000
5FT1-LTWC450H	E ceramic filter 7200	LTWC450H	1	CF3001
2CT1-TS32-160-100M	R tantalum capacitor	3216, 10 $\mu$ F $\pm$ 20%, 16V, TS series (level A)	28	C1000, C1005, C1014, C1019, C1020, C1025, C1030, C1031, C1057, C1058, C4024, C4029, C4040, C4045, C4047, C4052, C6002, C6008, C6011, C3029, C3030, C3046, C3067, C3094, C3097, C3109, C3112, C3113
2CC1-16-C0G500-101J	R flake multi-layer capacitor	1608, 100P $\pm$ 5%, 50V, C0G	60	C1001, C1004, C1010, C1015, C1018, C1021, C1024, C1026, C1029, C1034, C1035, C1037, C1039, C1042, C1044, C1046, C1049, C1051, C1053, C1056, C1059, C1063, C1064, C1104, C1105, C1112, C1119, C2008, C2010, C2012, C2017, C3003, C3004, C3027, C3031, C3040, C3042, C3047, C3082,

				C3091, C3095, C3110, C4021, C4022, C4025, C4028, C4034, C4035, C4036, C4037, C4038, C4039, C4041, C4044, C4048, C4051, C4056, C4059, C4060, C4061
2CC1-16-X7R50 0-103K	R flake multi-layer capacitor	1608, 10nF±10%, 50V, X7R	57	C1002, C1003, C1016, C1017, C1022, C1023, C1027, C1028, C1036, C1038, C1040, C1041, C1043, C1045, C1047, C1048, C1050, C1052, C1080, C1082, C3028, C3032, C3043, C3048, C3053, C3078, C3096, C3098, C3111, C4000, C4001, C4002, C4003, C4005, C4008, C4012, C4014, C4017, C4026, C4027, C4032, C4033, C4042, C4043, C4049, C4050, C4054, C4057, C5000, C5001, C5002, C5004, C5006, C5007, C5008, C6004, C6013
2CC1-16-C0G50 0-471J	R flake multi-layer capacitor	1608, 470P±5%, 50V, C0G	11	C3070, C1006, C1007, C1008, C1012, C1032, C1033, C1067, C1089, C1090, R3037
2CT1-TS32-6R3- 150M	R tantalum capacitor	3216, 15µF±20%, 6.3V, TS series (level A))	3	C1009, C1011, C1013
2CC1-16-C0G50 0-6R0C	R flake multi-layer capacitor	1608, 6P±0.25P , 50V, C0G	7	C1054, C1055, C2030, C2032, C3023, C3024, C3025
2CC1-16-C0G50 0-5R0B	flake multi-layer capacitor	1608, 5P±0.1P, 50V, C0G	11	C4062, C1060, C1061, C1062, C1076, C1111, C3010, C3011, C3013, C3014, C3015
2CC1-16-Y5V16 0-104Z	flake multi-layer capacitor	1608, 100nF+80%/-20%, 16V, Y5V	25	C1065, C1078, C1081, C1083, C1106, C1113, C2009, C2011, C2013, C2014, C2038, C3041, C3045, C3049, C3055, C3071, C3079, C3081, C3086, C3087, C3089,



				C3090, C3092, C3101, C3103
2CT1-TS32-350-R10M	R tantalum capacitor	3216, 0.1 $\mu$ F $\pm$ 20%, 35V, TS series (level A)	3	C1069, C3100, C1071
2CT1-TS32-350-R33M	R tantalum capacitor	3216, 0.33 $\mu$ F $\pm$ 20%, 35V, TS series (level A)	1	C1070
2CC1-16-X7R50 0-102K	R flake multi-layer capacitor	1608, 1000P $\pm$ 10%, 50V, X7R	21	C1072, C1092, C1093, C1097, C3033, C3034, C3035, C3036, C3037, C3038, C3044, C3073, C3075, C3093, C3099, C3102, C6001, C6003, C6010, C6012, C3076
2CT1-TS32-100-2R2M	R tantalum capacitor	3216, 2.2 $\mu$ F $\pm$ 20%, 10V, TS series (level A)	1	C1075
2CC1-16-C0G50 0-4R0B	flake multi-layer capacitor	1608, 4P $\pm$ 0.1P, 50V, C0G	4	C3000, C3005, C3006, C3019
2CC1-16-C0G50 0-8R0C	R flake multi-layer capacitor	1608, 8P $\pm$ 0.25P, 50V, C0G	4	C1079, C1108, C1068, C4007
2CC1-16-C0G50 0-470J	R flake multi-layer capacitor	1608, 47P $\pm$ 5%, 50V, C0G	49	C1084, C1099, C2024, C3007, C3008, C3009, C3039, C4011, C6021, C6022, C6023, C6024, C6025, C6027, C6028, C6029, C6030, C6031, C6032, C6033, C6034, C6035, C6037, C6038, C6039, C6040, C6042, C6043, C6044, C6045, C6046, C6047, C6048, C6049, C6050, C6051, C6052, C6053, C6054, C6055, C6056, C6058, C4013, C6059, C6060, C6061, C6062, C6064, C6065
2CC1-16-C0G50 0-100D	R flake multi-layer capacitor	1608, 10P $\pm$ 0.5P, 50V, C0G	3	C1085, C1086, C1100
2CC1-16-X7R50 0-271K	R flake multi-layer capacitor	1608, 270P $\pm$ 10%, 50V, X7R	2	C1087, C1088
2CC1-16-C0G50 0-680J	R flake multi-layer	1608, 68P $\pm$ 5%, 50V, C0G	3	C1091, C3056, C4053

	capacitor			
2CC1-16-C0G50 0-180J	R flake multi-layer capacitor	1608, 18P±5%, 50V, C0G	2	C1094, C3104
2CC1-16-C0G50 0-300J	R flake multi-layer capacitor	1608, 30P±5%, 50V, C0G	2	C1095, C1096
2CC1-16-C0G50 0-1R0B	flake multi-layer capacitor	1608, 1P±0.1P, 50V, C0G	10	C1101, C1103, C1116, C1117, C6020, C6026, C6036, C6041, C6057, C6063
2CC1-16-C0G50 0-390J	R flake multi-layer capacitor	1608, 39P±5%, 50V, C0G	2	C1102, C1118
2CC1-16-C0G50 0-820J	R flake multi-layer capacitor	1608, 82P±5%, 50V, C0G	2	C2020, C2026
2CC1-16-C0G50 0-121J	R flake multi-layer capacitor	1608, 120P±5%, 50V, C0G	2	C2021, C2023
2CC1-16-C0G50 0-620J	flake multi-layer capacitor	1608, 62P±5%, 50V, C0G	2	C2022, C2025
2CC1-16-C0G50 0-120J	R flake multi-layer capacitor	1608, 12P±5%, 50V, C0G	4	C2031, C3106, C1114, C1115
2CC1-16-C0G50 0-3R5C	R flake multi-layer capacitor	1608, 3.5P/3.6±0.25P, 50V, C0G	2	C3020, C1110
2CC1-16-C0G50 0-1R5B	flake multi-layer capacitor	1608, 1.5P±0.1P, 50V, C0G	1	C1109
2CC1-16-C0G50 0-2R0B	flake multi-layer capacitor	1608, 2P±0.1P, 50V, C0G	4	C2019, C3001, C3026, C3060
2RS1-16-000O	R flake multi-layer capacitor	1608, 0Ω	17	R1017, R1018, R1029, R2010, L2012, C3012, L3015, R3027, R3028, R3031, R3038, R3042, R4003, R6012, R6013, R6040, R6041
2CC1-16-C0G50 0-220J	R flake multi-layer capacitor	1608, 22P±5%, 50V, C0G	1	C3050
2CC1-16-C0G50 0-221J	R flake multi-layer	1608, 220P±5%, 50V, C0G	4	C3052, C3057, C3084, C3088

	capacitor			
2CC1-16-X7R50 0-331K	flake multi-layer capacitor	1608, 330P±10%, 50V, X7R	5	C3054, C3068, C3108, C3114, C3115
2CC1-16-C0G50 0-150J	R flake multi-layer capacitor	1608, 15P±5%, 50V, C0G	3	C3064, C3107, C3072
2CC1-16-X7R50 0-182K	R flake multi-layer capacitor	1608, 1800P±10%, 50V, X7R	1	C3077
2CC1-16-C0G50 0-160J	R flake multi-layer capacitor	1608, 16P±5%, 50V, C0G	1	C3080
2RE1-16-3301	Precision resistor	1608, 3.3K±1%	2	R3029, C3083
2CC1-16-X7R50 0-152K	flake multi-layer capacitor	1608, 1500P±10%, 50V, X7R	1	C3085
2CC1-16-Y5V50 0-104Z	flake multi-layer capacitor	1608, 0.1µF+80%/-20%, 50V, Y5V, replaced no: 2CC1-16-Y5V250-104Z	9	C4004, C4015, C4018, C4023, C4030, C4031, C4046, C4055, C4058
2CC1-16-C0G50 0-560J	R flake multi-layer capacitor	1608, 56P±5%, 50V, C0G	3	C4006, C4016, C3059
2CC1-16-C0G50 0-270J	R flake multi-layer capacitor	1608, 27P±5%, 50V, C0G	1	C4019
2CC1-16-C0G50 0-181J	flake multi-layer capacitor	1608, 180P±5%, 50V, C0G	1	C4020
2CE1-VS250-10 1M0607D	Aluminum electrolytic capacitor	SMD-6.3x7.7mm, 100uF/25V	1	C5003
2CT1-TS32-100- 220M	Tantalum capacitor	3216, 22µF±20%, 10V, TSn series (level A)	2	C5005, C6007
2CC1-16-Y5V25 0-105Z	flake multi-layer capacitor	1608, 1µF+80%/-20%, 25V, Y5V	3	R6004, C6014, C6015
1DS1-DA2S1010 0L	R switch diode	DA2S10100L	2	D1000, D1001
1DV1-HVC376B	R varactor (production halt)	HVC376B(B9)	26	D3001, D3002, D3003, D3004, D3005, D3006, D3007, D3008, D3009, D3010, D3011, D3012, D3013, D3014, D3015, D3016, D3017, D3018,

				D3019, D3020, D3021, D3022, D3023, D3024, D4000, D4001
1DS1-HSC277	R switch diode(producti on halt)	HSC277, 1608	4	D3025, D3026, D3027, D3028
1DS1-RB706F-40	R switch diode	Schottky diode RB706F-40, SOT-323	1	D3029
1DR1-MM3Z15VT1G	Electrostatic-preventive zener diode	MM3Z2V4T1],15V, W=1.2mm, L=2.5mm, H=1.0mm, leadfree	1	D5000
5FE1-BLM11A601S	R EMI suppression filter	1608, BLM11A601S/BLM18AG601S(0138-05)	44	L1000, L1001, L1003, L1004, L1008, L1009, L1010, L1012, L1014, L1018, L2001, L2002, L3019, FB4000, L6000, L6001, R6014, R6015, R6016, R6017, R6019, R6020, R6022, R6023, R6024, R6026, R6027, R6028, R6029, R6030, R6032, R6035, R6036, R6037, R6038, R6039, R6044, R6045, R6046, R6047, R6048, R6049, R6050, R6051
5XT3-JTBM450C24	R ceramic harmonic oscillator	Frequency detector, JTBM450C24, leadfree	1	FD3000
1IS1-SKY72310	PLL chip	SKY72310,24 pin QFN 4mmX4mm,leadfree(QFN-N24_B4x4-P0_5),leadfree	1	IC1000
1IS1-SPF5122Z	IC	SPF5122Z/2mm*2mm, 8PIN, 50MHz-4GHz	2	IC3000, IC3003
1IS1-GT3136	E patch IC	GT3136, SSOP16	1	IC3004
1IS1-SYM25DHW	Patch frequency mixer	SYM-25DHW+, 80to2500MHz, TTT167,Mini-Circuits, RoHS	1	IC3005
1IS1-TC75S51F	Patch single operational amplifier IC	TC75S51F, SSOP5-P-0.95	2	IC6001, IC6002
1IS1-PGA103	Broad band low noise amplifier	PGA-103+, 0.05to4GHz, SOT-89, PACKAGE, Mini-Circuits,RoHS	1	IC6003
1IM1-AT24C08C	E R analog	EEPROM,	1	IC6005

N-SH	commercial handheld radio and patch memorizer IC	AT24C08CN-SH(8-SOIC)		
2LW1-16UC-R33G	Patch winding conductor	1608, 330nH±2%(C1608BR33G), pb-free	10	L1005,L1006,L1011,L1015,L1023,L1024,L1026,L1027,L1028,L1030
2LL1-16-R82K	Laminated conductor	1608, 0.82uH±10%(MLF1608DR82K TA00)	2	L1007,L1029
2LL1-16-1R0K	R Laminated conductor	1608, 1uH±10%(MLF1608A1R0K)	2	L1025,L3013
2LW1-20UC-102J	Patch winding conductor	2012, 1uH±5%, ceramic core (C2012C-1R0J)	3	L2004, L3007, L3024
2LW1-16UC-120G	Patch winding conductor	1608, 12nH±2%, ceramic core (C1608CB-12NG)	1	L2006
2LW1-20UC-180J	R patch winding conductor	2012, 18nH±5%, ceramic core (C2012C-18NJ)	2	L2009, L2010
2RS1-20-000O	R flake resistor	2012, 0Ω	4	L2011, L2013, L3003, L3004
2LH1-R401R5-R03-05	R patch air core inductor	Wire diameter φ0.40, internal diameter φ1.5, 3 circles, pin height 0.5ml	2	L3000, L3002
2LH1-R401R5-R04-05	R patch air core inductor	Wire diameter φ0.40, internal diameter φ1.5, 4 circles, pin height 0.5mm	7	L3001, L3006, L3008, L3009, L3010, L3011, L3012
2LW1-25UC-103J	R patch winding inductor	2520, 10uH±5%, ceramic core (FLM2520-100J)	4	L3005, L4002, L4003, L1022
2LW1-16UC-271G	patch winding inductor	1608, 270nH±2%, ceramic core (C1608CB-R27G-RF)	2	L3016, L3021
2RS1-16-271J	R flake resistor	1608, 270Ω±5%	1	L3018
2LL1-16-R56K	R laminated inductor	1608, 560nH±10%(MLF1608DR56K)	2	L3022, L3023
2LW1-20UC-331J	patch winding inductor	2012, 330nH±5%, ceramic core (high frequency)	3	L4001, L1019, L1020
2LL1-16-3R3K	R laminated inductor	1608, 3.3uH±10%(MLF1608A3R3K TA00)	1	L4004

2LW1-25UC-332 K	patch winding inductor	2520, 3.3 $\mu$ H $\pm$ 10%, ceramic core (NL252018T-3R3K/NLV25 T-3R3K)	1	L4005
5FE1-BLM21P30 0S	R patch EMI suppressi on filter	2012, BLM21P300S/BLM21PG3 00S(0149-05)	1	L5000
1IS1-XC6209F30 2PR	Patch voltage stabilization IC	XC6209F302PR, SOT-89-5, 3.0V stable voltage	2	Q1000, Q4002
1TT1-2SC4617- R	R patch triode	2SC4617-R(BR), EMT3	2	Q1001, Q1005
1IS1-XC6209F50 2PR	Patch voltage stabilization IC	XC6209F502PR, SOT-89-5, 5.0V stable voltage	6	Q1002, Q1004, Q3000, Q3003, Q3005, Q4003
1IS1-XC6209F33 2PR	Patch voltage stabilization IC	XC6209F332PR, SOT-89-5, 3.3V stable voltage	3	Q1003, Q1006, Q4004
1TT1-2SC5006	patch triode	2SC5006	1	Q1007
1TF1-2SJ243	R patch FET	2SJ243-SMD	2	Q1008, Q1010
1TT1-2SC3356- R24	R patch triode	2SC3356-R24, SOT23, NPN	7	Q1009, Q1011, Q2002, Q3001, Q3002, Q3004, Q4000
1TT1-DTC114YE	patch triode	Digital triode DTC114YE-SMD	2	Q4001, Q5000
2RS1-16-472J	R flake resistor	1608, 4.7K $\pm$ 5%	8	R3033, R1006, R3021, R1000, R1001, R3019, R3044, R3047
2RS1-16-392J	R flake resistor	1608, 3.9K $\pm$ 5%	3	R1002, R1015, R3043
2RS1-16-682J	R flake resistor	1608, 6.8K $\pm$ 5%	2	R1003, R1043
2RS1-16-680J	R flake resistor	1608, 68 $\Omega$ $\pm$ 5%	2	R1004, R1044
2RE1-16-1200	Patch precision resistor	1608, 120 $\Omega$ $\pm$ 1%	5	C4009, C4010, R1021, R1005, R1025
2RS1-16-103J	R flake resistor	1608, 10K $\pm$ 5%	19	R6007, R6009, R1007, R1011, R1030, R1031, R1032, R1033, R1034, R1035, R1036, R1037, R1039, R1040, R1041, R3017, R4002, R4007, R4008

2RE1-16-1000	Patch precision resistor	1608, 100Ω±1%	11	R3002, R3003, R1020, R1008, R1009, R1010, R1013, R1014, R1016, R1022, R1024
2RE1-16-47R0	Patch precision resistor	1608, 47Ω±1%	1	R1019
2RS1-16-102J	R flake resistor	1608, 1K±5%	7	R1023, R1028, R1042, R3018, R3036, R4004, R4009
2RS1-16-124J	R flake resistor	1608, 120K±5%	1	R1026
2RS1-16-822J	R flake resistor	1608, 8.2K±5%	2	R2007, R5003
2RS1-16-270J	R flake resistor	1608, 27Ω±5%	1	R2009
2RS1-16-221J	R flake resistor	1608, 220Ω±5%	2	R2011, R2012
2RS1-16-510J	R flake resistor	1608, 51Ω±5%	1	R2018
2RS1-16-104J	R flake resistor	1608, 100K±5%	13	R3005, R3006, R3007, R3008, R3009, R3010, R3011, R3012, R3013, R3014, R3015, R3016, R4006
2RS1-16-821J	R flake resistor	1608, 820Ω±5%	1	R3022
2RS1-16-473J	R flake resistor	1608, 47K±5%	8	R3023, R3025, R5000, R5001, R6042, R6043, R6052, R6053
2RS1-16-182J	R flake resistor	1608, 1.8K±5%	2	R3024, R3026
2RS1-16-363J	R flake resistor	1608, 36K±5%	2	R3030, R3032
2RS1-16-223J	R flake resistor	1608, 22K±5%	4	R3039, R3040, R3045, R3046

2RS1-16-184J	R flake resistor	1608, 180K±5%	1	R3041
2RS1-16-364J	flake resistor	1608, 360K±5%	1	R3049
2RS1-16-562J	R flake resistor	1608, 5.6K±5%	2	R3050, R6000
2RS1-16-153J	R flake resistor	1608, 15K±5%	2	R3051, R6005
2RS1-16-560J	R flake resistor	1608, 56Ω±5%	2	R3052, L4000
2RS1-16-511J	flake resistor	1608, 510Ω±5%	1	R4000
2RS1-16-203J	R flake resistor	1608, 20K±5%	1	R4001
2RS1-16-513J	R flake resistor	1608, 51K±5%	1	R6001
2RS1-16-273J	R flake resistor	1608, 27K±5%	2	R6008, R6010
2RS1-16-362J	R flake resistor	1608, 3.6K±5%	1	R6011
1TC1-UMC4	R patch compound tube	UMC4, NPN/PNP compound tube	2	U1000, U3000
1IS1-AD9864	IF digital system	AD9864, LFCSP-N48_B7X6_75_P0_5, pb-free	1	U4000
1IS1-LM2941S	Patch specialized IC	LM2941S/TO-236, 5PIN, pb-free	1	U5000
5FQ1-LFCN-400	Low pass filter	LFCN-400, 8.5W, DC to 400MHz, FV1206, Mini-Circuits	1	U5002
5OT1-12R8-CEC 3-0503	R patch temperature compensated crystal oscillator	NT5032SA/NT5032SC, 12.8MHz±2.5PPm, 5.0*3.2*1.6mm	1	X1000
5FC1-DSF51R6 M-0705	R patch crystal filter, PT568/78/72/	DSF753SBF, 51.65MHz±4KHz/3dB, 7.0*5.0*1.3,	2	Z3000, Z3001



	62/65/68/DR5 5/DM58/3208/ V68/E66	DP77/CD37/RD47/AP57		
2LW1-20UC-120 J	patch winding inductor	2012, 12nH±5%, ceramic core (C2012C-12NJ)	1	L1016
1DV1-1SV305	R patch varactor	1SV305	8	D1002, D1003, D1004, D1005, D1006, D1007, D1008, D1009
2LW1-16UC-180 J	R patch winding inductor	1608, 18nH±5%, ceramic core (C1608CB-18NJ)	1	L1013
2LL1-16-R22K	R laminated inductor	1608, 0.22µH±10%(MLF1608D R22K TA00)	1	L3017
2CC1-16-C0G50 0-151J	R flake multi-layer capacitor	1608, 150P±5%, 50V, C0G	1	C3058
2RS1-16-561J	R flake resistors	1608, 560Ω±5%	1	R4005
2CC1-16-C0G50 0-2R5B	R R flake multi-layer resistor	1608, 2.5P/2.4P±0.1P, 50V, C0G	1	C1073
2LW1-20UC-180 G	patch winding inductor	ceramic core LQW2UAS18NG00 0805 18nH±2%	1	L1017
2CC1-16-C0G50 0-3R0B	flake multi-layer capacitor	1608, 3P±0.1P, 50V, C0G	2	C3002, C2018
2RS1-16-820J	flake resistor	1608, 82Ω±5%	1	R3000
3CR7-SMA-50K WE-2	RF coaxial connector	SMA-50KWE-2, 5PIN, 90 degrees, 23mm long. pitch: 2.54mm	2	J3000, J3002
3CB3-A2548WV- 2X13P	Board-board connector	2*13 socket, 180 degrees, spacing 2.54mm, 40.64X9X9.1mm, manufacturer: JOINT TECH	1	J6000

## Table2 Parts List (Tx Module Section)

Part No.	Accessory Names	Description	Quantity	Location
3FW1-42932-30 2320	R patch fuse	429003/433003/466003, 3216, 3A/32V	1	CB400

1DR1-MM3Z12V T1G	Electrostatic-p roof zener diode	MM3Z12VT1G, 3V, SOD323, pb-free	1	D400
1DS1-HSC277	R patch switch diode (production halt)	HSC277, 1608	1	D100
1DV1-1SV278	R patch varactor	1SV278(T1)	2	D105, D110
1DV1-1SV305	R patch varactor	1SV305	8	D101, D102, D103, D104, D106, D107, D108, D109
1IS1-LM2941S	Patch specialized IC	LM2941S/TO-236, 5PIN, Low dropout voltage regulator, pb-free	1	U400
1IS1-SKY72310	PLL chip	SKY72310, 24 pin QFN 4mmX4mm pb-free(QFN-N24_B4x4- P0_5), pb-free	1	IC100
1IS1-SPF5122Z	Patch specialized IC	SPF5122Z/2mm*2mm, 8PIN, 50MHz-4GHz low noise amplifier, pb-free	1	IC304
1IS1-TC75S51F	Patch single operational amplification IC	TC75S51F, SSOP5-P-0.95	2	IC300, IC301
1IS1-XC6209F30 2PR	Patch voltage stabilization IC	XC6209F302PR, SOT-89-5, stable 3.0V voltage	1	IC101
1IS1-XC6209F33 2PR	Patch voltage stabilization IC	XC6209F332PR, SOT-89-5, stable 3.3V voltage	1	IC103
1IS1-XC6209F50 2PR	Patch voltage stabilization IC	XC6209F502PR, SOT-89-5, stable 5.0V voltage	4	IC102, IC104, IC105, IC302
1TC1-UMC4	R patch compound tube	UMC4, NPN/PNP compound tube	1	U100
1TF1-2SJ243	R patch FET	2SJ243-SMD	1	Q104
1TT1-2SC3356- R24	R patch triode	2SC3356-R24, SOT23, NPN	3	Q105, Q106, Q202
1TT1-2SC4617- R	R patch triode	2SC4617-R(BR), EMT3	1	Q101
1TT1-DTC114YE	patch triode	Digital triode DTC114YE-SMD	2	Q204, Q400
1TT1-FMMT717	R patch triode	FMMT717A, PNP,	1	Q203

TA		SOT23		
2CC1-16-C0G50 0-100D	R flake multi-layer capacitor	1608, 10P±0.5P, 50V, C0G	2	C188, C189
2CC1-16-C0G50 0-101J	R flake multi-layer capacitor	1608, 100P±5%, 50V, C0G	64	C161, C166, C167, C182, C184, C186, C199, C208, C212, C214, C216, C224, C228, C234, C239, C242, C246, C255, C289, C291, C295, C297, C300, C301, C302, C303, C304, C305, C306, C307, C308, C309, C310, C311, C312, C315, C316, C317, C320, C321, C322, C323, C340, C341, C344, C345, C102, C106, C111, C113, C117, C119, C123, C124, C138, C140, C142, C144, C146, C150, C151, C153, C157, C160,
2CC1-16-C0G50 0-102J	flake multi-layer capacitor	1608, 1000P±5%, 50V, C0G	8	C175, C240, C325, C329, C332, C334, C342, R333
2CC1-16-C0G50 0-120J	R flake multi-layer capacitor	1608, 12P±5%, 50V, C0G	3	C131, C132, C230
2CC1-16-C0G50 0-121J	R flake multi-layer capacitor	1608, 120P±5%, 50V, C0G	1	C244
2CC1-16-C0G50 0-180J	R flake multi-layer capacitor	1608, 18P±5%, 50V, C0G	1	C171
2CC1-16-C0G50 0-1R0B	flake multi-layer capacitor	1608, 1P±0.1P, 50V, C0G	10	C129, C133, C135, C169, C177, C179, C313, C314, C318, C319
2CC1-16-C0G50 0-430J	R flake multi-layer capacitor	1608, 43P±5%, 50V, C0G	1	C221
2CC1-16-C0G50	R flake	1608, 47P±5%, 50V,	2	C220, C256

0-470J	multi-layer capacitor	C0G		
2CC1-16-C0G50 0-471J	R flake multi-layer capacitor	1608, 470P±5%, 50V, C0G	4	C105, C107, C108, C127
2CC1-16-C0G50 0-4R0C	R flake multi-layer capacitor	1608, 4P±0.25P, 50V, C0G	3	C128, C168, C170
2CC1-16-C0G50 0-5R0B	flake multi-layer capacitor	1608, 5P±0.1P, 50V, C0G	4	C130, C163, C164, C165
2CC1-16-C0G50 0-620J	flake multi-layer capacitor	1608, 62P±5%, 50V, C0G	4	C225, C232, C233, C257
2CC1-16-C0G50 0-6R0C	R flake multi-layer capacitor	1608, 6P±0.25P, 50V, C0G	5	C155, C156, C183, C231, C235
2CC1-16-C0G50 0-820J	R flake multi-layer capacitor	1608, 82P±5%, 50V, C0G	4	C136, C181, C222, C226
2CC1-16-C0G50 0-8R0C	R flake multi-layer capacitor	1608, 8P±0.25P, 50V, C0G	1	C176
2CC1-16-C0G50 0-9R0C	R flake multi-layer capacitor	1608, 9P±0.25P, 50V, C0G	1	C137
2CC1-16-X7R50 0-103K	R flake multi-layer capacitor	1608, 10nF±10%, 50V, X7R	29	C101, C103, C116, C118, C122, C125, C139, C141, C143, C145, C147, C152, C154, C245, C253, C290, C292, C296, C298, C326, C335, C343, C400, C401, C402, C404, C406, C407, C408
2CC1-16-X7R50 0-332K	flake multi-layer capacitor	1608, 3300P±10%, 50V, X7R	1	C336
2CC1-16-X7R50 0-333K	R flake multi-layer capacitor	1608, 33nF±10%, 50V, X7R	1	C327
2CC1-16-Y5V16 0-104Z	flake multi-layer capacitor	1608, 100nF+80%/-20%, 16V, Y5V	19	C110, C112, C114, C158, C159, C162, C185, C187, C195, C196, C209, C213,

				C215, C217, C227, C229, C238, C241, C243
2CC1-16-Y5V50 0-474Z	flake multi-layer capacitor	1608, 470nF+80%/-20%, 50V, Y5V	1	R344
2CE1-VS250-10 1M0607D	Patch aluminum electrolytic capacitor	SMD-6.3x7.7mm, 100uF/25V	1	C403
2CT1-TS32-100- 2R2M	R patch tantalum capacitor	3216, 2.2 $\mu$ F $\pm$ 20%, 10V, TS series (level A)	1	C178
2CT1-TS32-160- 100M	R patch tantalum capacitor	3216, 10 $\mu$ F $\pm$ 20%, 16V, TS series (level A)	22	C100, C104, C115, C120, C121, C126, C192, C252, C254, C282, C283, C284, C285, C286, C287, C288, C293, C294, C299, C328, C333, C405
2CT1-TS32-350- R10M	R patch tantalum capacitor	3216, 0.1 $\mu$ F $\pm$ 20%, 35V, TS series (level A)	1	C172
2CT1-TS32-350- R33M	R patch tantalum capacitor	3216, 0.33 $\mu$ F $\pm$ 20%, 35V, TS series (level A)	1	C173
2CT1-TS32-6R3- 150M	R patch tantalum capacitor	3216, 15 $\mu$ F $\pm$ 20%, 6.3V, TS series (level A)	1	C109
2LL1-16-R82K	Laminated inductor	1608, 0.82uH $\pm$ 10%(MLF1608D R82K TA00)	2	L105, L117
2LW1-16UC-120 G	Patch winding inductor	1608, 12nH $\pm$ 2%, ceramic core (C1608CB-12NG)	1	L205
2LW1-16UC-180 G	Patch winding inductor	1608, 18nH $\pm$ 2%, ceramic core (C1608CB-18NG)	2	L113, C237
2LW1-16UC-R33 G	Patch winding inductor	1608, 330nH $\pm$ 2%(C1608BR33 G), pb-free	6	L103, L104, L111, L115, L116, L120
2LW1-20UC-102 J	Patch winding inductor	2012, 1 $\mu$ H $\pm$ 5%, ceramic core (C2012C-1R0J)	1	L214
2LW1-20UC-120 GM	Patch winding inductor	ceramic core LQW2UAS12NG00 ;,	1	L119

		12nH±2%		
2LW1-20UC-180 J	R Patch winding inductor	2012, 18nH±5%, ceramic core (C2012C-18NJ)	2	L209, L210
2LW1-20UC-331 J	Patch winding inductor	2012, 330nH±5%, ceramic core (high frequency)	2	L106, L118
2LW1-20UC-8R2 J	Patch winding inductor	2012, 8.2nH±5%, ceramic core (C2012C-8N2J)	1	L107
2LW1-25UC-103 J	R Patch winding inductor	2520, 10µH±5%, ceramic core (FLM2520-100J)	1	L122
2RE1-16-1000	Patch precision resistor	1608, 100Ω±1%	9	R105, R106, R113, R115, R117, R119, R120, R121, R128
2RE1-16-1001	Patch precision resistor	1608, 1K±1%	2	R134, R135
2RE1-16-1200	Patch precision resistor	1608, 120Ω±1%	2	R108, R129
2RE1-16-1801	Patch precision resistor	1608, 1.8K±1%	1	C339
2RE1-16-47R0	Patch precision resistor	1608, 47Ω±1%	1	R124
2RE1-16-8201	R Patch precision resistor	1608, 8.2K±1%	2	R342, R403
2RS1-16-000O	R Flake resistor	1608, 0Ω	23	R122, R123, R125, R130, R131, R137, R138, C191, R210, L211, R313, R314, R315, R316, R319, R320, R325, R326, R334, R335, R346, R348, R350
2RS1-16-103J	R Flake resistor	1608, 10K±5%	9	R114, R132, R133, R140, R141, R142, R143, R144, R145
2RS1-16-104J	R Flake resistor	1608, 100K±5%	6	R100, R103, R107, R111, R118, R127
2RS1-16-123J	R Flake resistor	1608, 12K±5%	2	R337, R343

2RS1-16-124J	R Flake resistor	1608, 120K±5%	2	R339, R341
2RS1-16-220J	R Flake resistor	1608, 22Ω±5%	1	R218
2RS1-16-221J	R Flake resistor	1608, 220Ω±5%	2	R211, R212
2RS1-16-270J	R Flake resistor	1608, 27Ω±5%	1	R209
2RS1-16-302J	Flake resistor	1608, 3K±5%	2	R104, R116
2RS1-16-472J	R Flake resistor	1608, 4.7K±5%	2	R101, R109
2RS1-16-473J	R Flake resistor	1608, 47K±5%	5	R110, R220, R345, R400, R401
2RS1-16-511J	Flake resistor	1608, 510Ω±5%	1	R219
2RS1-16-563J	R Flake resistor	1608, 56K±5%	1	R207
2RS1-16-682J	R Flake resistor	1608, 6.8K±5%	2	R102, R112
2RS1-20-000O	R Flake resistor	2012, 0Ω	2	L212, L213
5FE1-BLM11A601S	R patch EMI suppression filter	1608, BLM11A601S/BLM18AG601S(0138-05)	28	L100, L101, L102, L108, L109, L110, L112, L114, L121, L123, L202, L207, L300, R301, L301, R302, R303, R304, R305, R306, R307, R308, R309, R310, R311, R312, R329, R351
5FE1-BLM21P300S	R patch EMI suppression filter	2012, BLM21P300S/BLM21PG300S(0149-05)	1	L400
5FQ1-LFCN-400	Low pass filter	LFCN-400, 8.5W, DC to 400MHz, FV120, Mini-Circuits	1	U402
5OT1-12R8-CEC3-0503	R patch temperature compensated crystal oscillator	NT5032SA/NT5032SC, 12.8MHz±2.5PPm, 5.0*3.2*1.6mm	1	X100
6PM7-4067-HTB	DR650-02Tx board	DR650-DVC0-TXBORA D-20130319.PCB, 1.6MM thick, FR-4, 70X194M, 4 layers	1	
2RE1-16-2200	Patch precision resistor	1608, 220Ω±1%	1	R126

3CB3-A2548WV-2X10P	Board-to-board connector	2*10 socket, spacing 2.54mm, 33.02X9X9.1mm, black, manufacturer:JOINT TECH	1	J300
3CR7-SMA-50KWE-2	RF coaxial connector	SMA-50KWE-2, 5PIN plug-in unit, 90 degrees, 23mm long.pitch:2.54mm	1	J200

### Table3 Parts List (Power Amplification Section)

Part No.	Accessory Names	Description	Quantity	Location
3CB1-DC002	STR-U the power amplifier board power supply socket	DC-002, combination key, plastic pedestal+two copper patches, pb-free	1	J302
2RV3-22ZR-10D	R plug-in unit piezoresistor	22ZR-10D	1	R306
3CR7-SMA-50KWE-2	Rf coaxial connector	SMA-50KWE-2, 5PIN plug-in unit, 90 degrees, 23mm long.pitch:2.54mm	1	J100
3CB3-A2548WV-2X05P	Board-to-board connector	A2548WV-2X05P, 180 degrees, 2.54mm spacing, 20.32mmX9mmX9.1mm,	1	J300
1IS3-DS18B20	IC	temperature sensor, 3.0V-5.5Vpower supply, -55°C--125°C, TO-92	1	IC101
3FW1-42932-302320	R patch fuse	429003/433003/466003, 3216, 3A/32V	1	CB300
2CE1-VS250-101M0607D	Patch aluminum electrolytic capacitor	SMD-6.3x7.7mm, 100uF/25V	3	C100, C105, C203
2CC1-16-C0G500-101J	R flake multi-layer capacitor	1608, 100P±5%, 50V, C0G	37	C101, C103, C106, C108, C110, C112, C113, C114, C116, C121, C122, C123, C124, C137, C139, C150, C161, C164,



				C167, C300, C301, C302, C303, C304, C305, C306, C307, C308, C309, C310, C311, C312, C313, C314, C315, C316, C317
2CC1-16-Y5V16 0-104Z	flake multi-layer capacitor	1608, 100nF+80%/-20%, 16V, Y5V	10	C102, C104, C107, C109, C115, C129, C138, C140, C142, C143
2CT1-TS32-6R3- 100M	Patch tantalum capacitor	3216, 10 $\mu$ F $\pm$ 20%, 6.3V, TS series (level A)	3	C111, C136, C166
2CC1-16-C0G50 0-160J	R flake multi-layer capacitor	1608, 16P $\pm$ 5%, 50V, C0G	1	C117
2CC1-32-C0G10 2-2R0J	R flake multi-layer capacitor	3216, 2P $\pm$ 0.25P, 1000V, C0G	3	C118, C132, C135
2CC1-32-C0G10 1-102J	flake multi-layer capacitor	3216, 1000P $\pm$ 5%, 100V, C0G, GRM3195C2A102JA01 D	3	C125, C126, C160
2CC1-16-C0G50 0-2R0B	flake multi-layer capacitor	1608, 2P $\pm$ 0.1P, 50V, C0G	2	C127, C130
2CC1-32-C0G10 2-4R0J	R flake multi-layer capacitor	3216, 4P $\pm$ 0.25P, 1000V, C0G	1	C133
2CC1-32-C0G10 2-5R0J	R flake multi-layer capacitor	3216, 5P $\pm$ 5%, 1000V, C0G	1	C134
2CC1-16-C0G50 0-471J	R flake multi-layer capacitor	1608, 470P $\pm$ 5%, 50V, C0G	8	C141, C145, C147, C152, C154, C155, C156, C157
2CC1-16-C0G50 0-5R0C	R flake multi-layer capacitor	1608, 5P $\pm$ 0.25P, 50V, C0G	2	C144, C146
2CC1-16-C0G50 0-102J	flake multi-layer capacitor	1608, 1000P $\pm$ 5%, 50V, C0G	1	C148
2CC1-16-C0G50 0-221J	R flake multi-layer capacitor	1608, 220P $\pm$ 5%, 50V, C0G	1	C149
2CC1-16-X7R50	R flake	1608, 10nF $\pm$ 10%, 50V,	10	C153, C162, C165,

0-103K	multi-layer capacitor	X7R		C200, C201, C202, C204, C206, C207, C208
2CT1-TS32-100-220M	Patch tantalum capacitor	3216, 22 $\mu$ F $\pm$ 20%, 10V, TS series (level A)	1	C205
1DR1-MM3Z15V T1G	Patch electrostatic-proof zener diode	MM3Z2V4T1 series, 15V, W=1.2mm, L=2.5mm, H=1.0mm, pb-free	3	D100, D101, D200
1DZ1-HZU5ALL	R patch voltage stabilization diode (production halts)	HZU5ALL, 2012, 5V	1	D102
1DS1-RB706F-40	R patch switch diode	Schottky tube RB706F-40, SOT-323	2	D103, D104
1DS1-HVC131	R patch switch diode (production halts)	HVC131(P1), 1608	1	D202
1IL1-NJM2904V	R patch linear IC	Dual calculation amplification NJM2904V, TSSOP-8	1	IC100
1IM1-AT24C08C N-SH	E R analog commercial portable and mobile patch memorizer IC	EEPROM, AT24C08CN-SH(8-SOIC )	1	IC6005
5FE1-BLM41P600SPT	R patch EMI suppression filter	EMI, FILTER, SMT, BLM41P600SPT, 1206, pb-free	3	L100, L101, L102
5FE1-BLM11A601S	R patch EMI suppression filter	1608, BLM11A601S/BLM18AG 601S(0138-05)	11	L103, L110, R300, R301, R302, R303, R304, R305, R308, R309, R310
2LW1-20UC-330GA	R patch winding inductor	2012, 33nH $\pm$ 2%(C2012C-33NG)	1	L104
2LL1-16-8N2D	Laminated inductor	1608, 8.2nH $\pm$ 0.5nH(MLG1608 B8N2DT)	2	L105, L106
2LH1-R903R0-L02-03	R patch air core inductor	wire diameter $\phi$ 0.9, internal diameter $\phi$ 3.0, 1.5 circles, back-roll, ,	3	L107, L108, L109

		pb-free		
2RS1-16-471J	R flake resistor	1608, 470Ω±5%	1	L111
2LH1-R903R0-L11-05	R patch air core inductor	wire diameterφ0.9, internal diameterφ3.0, 11 circles, pin height 0.5mm, back-roll	1	L112
2LL1-16-47NJ	R Laminated inductor	1608, 47nH±5%(MLG1608B47NJ)	2	L114, L115
5FE1-BLM21P300S	R patch EMI suppression filter	2012, BLM21P300S/BLM21PG300S(0149-05)	1	L200
1TT1-FMMT717TA	R patch triode	FMMT717A, PNP, SOT23	2	Q100, Q103
1TT1-DTC114YE	patch triode	Digital triode DTC114YE-SMD	3	Q101, Q104, Q200
1TT1-2SC3357	R patch triode	2SC3357(RE), SOT89(NEC)	1	Q102
2RS1-16-473J	R Flake resistor	1608, 47K±5%	9	R100, R118, R133, R200, R201, R6042, R6043, R6052, R6053
2RS1-16-561J	R Flake resistor	1608, 560Ω±5%	2	R101, R119
2RE1-16-8201	R patch precision resistor	1608, 8.2K±1%	2	R102, R203
2RS1-16-820J	Flake resistor	1608, 82Ω±5%	2	R105, R115
2RE1-16-1501	R patch precision resistor	1608, 1.5K±1%	1	R106
2RS1-16-270J	R Flake resistor	1608, 27Ω±5%	2	R108, R109
2RS1-16-221J	R Flake resistor	1608, 220Ω±5%	4	R110, R111, R112, R114
2RS1-16-000O	R Flake resistor	1608, 0Ω	8	R130, R141, R113, R128, R143, R146, R147, R311
2RS1-16-222J	R Flake resistor	1608, 2.2K±5%	1	R120
2RS1-16-103J	R Flake resistor	1608, 10K±5%	7	R121, R122, R123, R124, R125, R129, R307
2RS1-16-202J	R Flake resistor	1608, 2K±5%	1	R126
2RS1-16-104J	R Flake	1608, 100K±5%	1	R127

	resistor			
2RS1-16-821J	R Flake resistor	1608, 820Ω±5%	1	R131
2RS1-16-510J	R Flake resistor	1608, 51Ω±5%	1	R134
2RS1-16-512J	Flake resistor	1608, 5.1K±5%	3	R137, R138, R135
2RE1-16-1000	patch precision resistor	1608, 100Ω±1%	1	R142
1IS1-XC6701D3 32PR	3.3VLDO	28V high input voltage, fast speed and low consumption LDO with fast speed and low consumption, 3.3V output, SOT-89	1	U102
1IS1-LM2941S	Patch specialized IC	LM2941S/TO-236, 5PIN, low dropout voltage regulator, pb-free	1	U200
6PM7-4071-HPA	SEPURA power amplification board PCB	power amplification board PCB, four layers, FR4, 58.24X70, RFAMPLIFIER-2013071 9.PCB, pb-free	1	
2CC1-32-C0G50 1-1R0C	Flake multi-layer capacitor	3216, 1P±0.25%, 500V, C0G, GRM31M5C2H1R0CY2 1B	1	C119
1DR1-XBS053V 15R-1G	Patch schottky diode	XBS053V15R-1G, SOD-523, VR=20V, VF=0.40V, manufactured by TOREX, pb-free	1	D201
2CC1-32-C0G50 0-102J	Flake multi-layer capacitor	3216, 1000P±5%, 50V, C0G	1	L113

## Table4 Parts List (Baseband Mainboard)

Part No.	Accessory Names	Quantity	Location
3CB3-VH3096-2P	DC power socket	1	J1
3CB3-S6160BK1	Board-to-board connector	2	J2
3CR7-SMA-50KE	RF coaxial connectorw	3	J6, J7, J8
3CB3-A2548WV-2X05P	Board-to-board connector	4	J5, J18, J19, J23
3CB3-A2548WV-2X13P	Board-to-board connector	2	J9, J15

3CT3-KRJ003NL-8P	Crystal head RJ45 socket	1	J12
3CB3-A2548WV-2X10P	Board-to-board connector	1	J17
3CL3-PH-20002	Bar connector	1	J20
3CL3-PH-25402A	Bar connector	1	J27
2RV3-22ZR-10D	piezoresistor	1	R2
2CE3-GM350-102M1320	Aluminum electrolytic capacitor	2	C331, C522
3CL3-PH-20003	Bar connector	1	J21
2LI3-0911-331K	I-shaped inductor	3	L12, L16, L17
7MBC-4073-04A-W	Large shield	4	P1, P2, P4, P5
7MBC-4073-05A-W	Small shield	1	P3
6BLS-4814-03327U	Patch button battery	1	BT2
2CC1-16-X7R500-103K	Flake multi-layer capacitor	1	C1
2CC1-32-Y5V500-106Z	Flake multi-layer capacitor	23	C2, C6, C21, C24, C29, C30, C31, C109, C175, C182, C183, C226, C263, C277, C285, C286, , C251, C275, C288, , C506, C507, C512, C513
2CC1-16-Y5V500-104Z	Flake multi-layer capacitor	52	C3, C7, C8, C9, C12, C17, C19, C22, C27, C90, C91, , C95, C96, C97, C103, C105, C106, C110, C115, C116, C136, C244, C318, C429, C459, C262, C146, C147, , C170, C171, C172, C174, C177, C178, C180, C181, C194, C195, C205, C206, C225, C264, C265, C279, C282, C290, C291, C294, C297, C299, C302, C304,
2CC1-16-C0G500-101J	Flake multi-layer capacitor	32	C245, C517, C518, C519, C520, C521, C531, C532, C519, C520, C381, C385, C283, C284, C295, C300, C4, C35, C36, C37, C48, C60, C75, C148, C246, C309, C327, C345, C371, C374, C508, C514
2CE1-VS250-101M0607D	Patch aluminum electrolytic capacitor	7	C5, C13, C289, C316, C405, C406, C411
2CC1-32-Y5V100-226Z	Flake multi-layer capacitor	19	C523, C524, C525, C526, C527, C528, C529, C530, C10, C11, C16, C18, C26, C107, C111, C113, C142, C145, C428

2CC1-16-X7R500-102K	Flake multi-layer capacitor	3	C14, C20, C388
2CC1-16-C0G500-470J	Flake multi-layer capacitor	1	C15
2CC1-16-Y5V250-105Z	Flake multi-layer capacitor	50	C292, C293, C25, C66, C67, C68, C81, C82, C83, C100, C108, C114, C117, C122, C123, C124, C143, C144, C154, C155, C156, C187, C188, C189, C190, C191, C200, C201, C202, C203, C204, C266, C267, C268, C269, C271, C273, , C276, C278, C281, C287, C112, C137, C234, C235, C324, C332, C298, C511, C460
2CC1-16-X7R100-225K	Flake multi-layer capacitor	1	C28
2CC1-20-Y5V160-106Z	Flake multi-layer capacitor	18	C533, C534, C32, C33, C34, C101, C118, C119, C120, C121, C138, C139, C176, C179, , C242, C319, C325, C369
2CC1-16-C0G500-100D	Flake multi-layer capacitor	8	C38, C39, C49, C61, C76, C92, C93, C149
2CC1-16-X5R6R3-475K	Flake multi-layer capacitor	23	C384, C380, C50, C51, C52, C53, C62, C63, C64, C65, C77, C78, C79, C80, C150, C151, C152, C153, C198, C199, C218, C228, C236
2CC1-16-C0G500-270J	Flake multi-layer capacitor	1	C102
2CC1-16-C0G500-4R5C	Flake multi-layer capacitor	1	C104
2CC1-32-C0G102-102J	Flake multi-layer capacitor	1	C173
2CC1-16-C0G500-221J	Flake multi-layer capacitor	3	C184, C185, C186
2CC1-16-C0G500-330J	Flake multi-layer capacitor	29	C306, C382, C386, C207, C208, C209, C210, C213, C214, C215, C220, C221, C222, C223, C224, C247, C248, C249, C252, C255, C258, C259, C317, C326, C372, C375, C377, C509, C515
2CC1-16-X7R500-471K	Flake multi-layer capacitor	15	C387, C383, C280, C370, C373, C376, C378, C379, C407, C408, C409, C410, C427, C510, C516
2CC1-10-X7R160-104K	Flake multi-layer capacitor	126	C40, C41, C42, C43, C44, C45, , C54, C55, C56, C57,

			C58, C59, C69, C70, C71, C72, C73, C74, C84, C85, C86, C87, C88, C89, C94, C98, C99, C125, C126, C127, C128, C129, C130, C131, C132, C133, C134, C135, C140, C141, C157, C158, C159, C160, C161, C162, C163, C164, C165, C166, C167, C168, C169, C270, C461, C462, C463, C464, C465, C466, C467, C468, C469, C470, C471, C472, C473, C474, C475, C476, C477, C478, C479, C480, C481, C482, C483, C484, C485, C486, C487, C488, C489, C490, C491, C492, C493, C494, C495, C496, C497, C498, C499, C500, C430, C431, C432, C433, C434, C435, C436, C437, C438, C439, C440, C441, C442, C443, C444, C447, C504, C505, C448, C449, C450, C451, C452, C453, C454, C455, C456, C457, C458, C501, C502, C503
2CC1-10-C0G500-271J	Flake multi-layer capacitor	35	C46, C47, C227, C229, C230, C231, C232, C233, , C238, C239, C240, C315, C321, , C333, C334, C335, C336, C337, C338, C339, C340, C341, C342, C343, C344, , C346, C347, C348, C349, C350, C351, C352, C353, C354, C357
2CC1-10-C0G500-471J	Flake multi-layer capacitor	31	C389, C390, C391, C392, C393, C394, C395, C396, C397, C398, C399, C400, C401, C402, C403, C404, C412, C413, C414, C415, C416, C417, C418, C419, C420, C421, C422, C423, C424, C425, C426
1DG1-DSM3MA1	Patch normal diode	1	D2

1DR1-SMCJ20A	Patch diode	1	D1
1DR1-SS36	Patch commutation diode	1	D3
1DS1-DA2S10100L	Patch switch diode	4	D8, D11, D12, D13
1DS1-HVC131	Patch switch diode	2	D9, D15
1DP1-BV03C	TVS diode	1	D10
1DS1-DAN222	Patch switch diode	1	D14
1DR1-MMBZ20VALT1G	TVS diode	6	D16, D17, D18, D19, D20, D5
1TT1-2SA1641-S	Patch triode	1	Q42
1DS1-DA204U	Patch switch diode	2	D7, D21
5FE1-BLM15AG221SN1D	EMI suppression filter	50	FB1, FB2, FB3, FB4, FB5, FB17, FB18, , FB25, FB26, FB27, FB28, FB29, FB30, FB31, FB35, FB36, FB37, FB38, FB39, FB40, FB41, FB42, FB43, FB44, FB45, FB46, FB47, FB48, FB49, FB50, FB51, FB52, FB53, FB54, FB55, FB56, FB57, FB58, FB59, FB60, FB62, FB63, FB64, R77, R84, R85, R86, R87, R88, R89
5FE1-BLM41P600SPT	EMI suppression filter	7	L8, L10, L11, FB20, FB22, L14, L15
5FE1-BLM18PG181SN1	EMI suppression filter	16	FB6, FB7, FB8, FB9, FB10, FB11, FB12, FB13, FB14, FB15, FB19, FB21, FB24, FB61, FB33, FB34
2RS1-16-0000	Flake resistor	18	C241, C320, R208, R231, R332, R213, R217, FB16, R22, R24, R209, R210, R214, R224, R225, R94, R107, R109
3FW1-42932-302320	Patch fuse	1	F1
4PE1-16-F5	Patch LED	4	LED2, LED3, LED4, LED5
4PE1-16-F2	Patch LED	1	LED6
2LG1-NR8040T842-4R7S	Patch power inductor	1	L1
2LG1-SWPA4020-2R2S	Patch power inductor	4	L2, L3, L4, L6
2LW1-16UC-221J	Patch winding inductor	1	L5
2LW1-20UC-180J	Patch winding inductor	2	L7, L33
2LW1-20UC-220J	Patch winding inductor	2	L13, L32
2LW1-16UC-181J	Patch winding inductor	2	L22, L26
2LW1-16UC-221G	Patch winding inductor	1	L24
2LW1-16UC-271G	Patch winding inductor	1	L25
2LI1-1608-R47G	I-shaped inductor	2	L21, L23
2LW1-25UC-681JA	Patch winding inductor	1	L20



1TT1-DTC114YE	Patch triode	18	Q1, Q2, Q5, Q8, Q10, Q12, Q13, Q14, Q15, Q16, Q17, Q18, Q19, Q20, Q21, Q22, Q23, Q24
1TT1-MMBT3904	Patch triode	2	Q3, Q9
2RE1-16-49R9	Patch precision resistor	4	R160, R166, R167, R168
2RE1-16-1001	Patch precision resistor	2	R32, R33
2RE1-16-2001	Patch precision resistor	1	R4
2RS1-16-332J	Flake resistor	4	R179, R293, R294, R363
2RE1-16-4871	Patch precision resistor	1	R172
2RE1-16-8201	Patch precision resistor	1	R18
2RE1-16-1002	Patch precision resistor	3	R1, R120, R121
2RE1-16-4302	Patch precision resistor	2	R13, R366
2RE1-16-18R0	Patch precision resistor	3	R28, R29, R95
2RS1-16-303J	Flake resistor	1	R5
2RS1-16-100J	Flake resistor	2	R6, R302
2RS1-16-103J	Flake resistor	56	R7, R8, R9, R10, R14, R15, R16, R17, R19, R20, R21, R23, R25, R26, R53, R54, R56, R57, R163, R174, R175, R176, R177, R182, R183, R186, R187, R188, R189, R190, R192, R193, R195, R196, R197, R198, R232, R259, R118, , R199, R200, R201, , R206, R211, R228, R230, R295, R296, R298, R299, R301, R303, R327, R353, R355, R367
2RS1-16-510J	Flake resistor	1	R27
2RS1-16-472J	Flake resistor	10	C260, C261, R133, R134, R138, R140, R161, R169, R202, R203
2RS1-16-330J	Flake resistor	55	R123, R215, R218, R223, R237, R238, R239, R240, R241, R242, R243, R244, R245, R246, R247, R248, R249, R250, R251, R252, R254, R279, R280, R281, R282, R283, R285, R286, R288, R289, R146, R147, R148, R149, R164, R165, R171, R207, R229, R291, R305, R306, R307, R308, R309, R310, R311, R312, R313, R314, R315, R348,

			R350, R362, C296
2RS1-16-101J	Flake resistor	11	R142, R143, R59, R105, R106, R180, C272, R92, R93, C274, FB32
2RS1-16-681J	Flake resistor	1	R233
2RS1-16-473J	Flake resistor	2	R119, R300
2RS1-16-102J	Flake resistor	14	R91, R97, R98, R99, , R137, R156, R157, R158, R159, R219, R253, R304, R329, R333
2RS1-16-222J	Flake resistor	5	R122, R170, R290, R292, R364
2RS1-16-755J	Flake resistor	1	R173
2RS1-16-104J	Flake resistor	1	R205
2RS1-16-471J	Flake resistor	2	R220, R222
2RS1-10-000O	Flake resistor	4	R260, R51, R96, R41
2RS1-10-330J	Flake resistor	26	R64, R73, R74, R75, R76, R78, R79, R101, R102, R108, R36, R37, R39, R40, R42, R43, R126, R127, R135, R136, , R150, R151, R152, R153, R154, R155
2RS1-10-101J	Flake resistor	3	R103, R104, R111
2RS1-10-472J	Flake resistor	9	R60, R61, R62, R63, R34, R38, R80, R81, R145
2RS1-10-103J	Flake resistor	21	R45, R46, R47, R48, R49, R50, R65, R66, R67, R72, R114, R116, R124, R125, R128, R129, R130, R131, R132, R204, R115
1IS1-TPS54331DDA	Patch switch power IC	1	U1
1IS1-TPS65023	Power management chip	1	U2
1IS1-LM2941S	Patch specialized IC	1	U3
1IP1-OMAPL138BZWT3	Dual-core CPU	1	U4
1IM1-MT47H64M16	Patch memorizer IC	1	U6
1IM1-K9GAG08U0M-I	Patch memorizer IC	1	U7
1IS1-TPS2051BDGN	LDO power voltage regulator IC	1	U8
1IS1-RT9193-33PB	Patch voltage regulator IC	1	U12
1IS1-RT8008GB	Patch voltage transformer IC	1	U13
1IS1-EP4CE30F23I7N	Patch specialized IC	1	U14
1IS1-RT9193-25PB	Patch voltage regulator IC	1	U15
1IS1-DP83848I	Patch specialized IC	1	U17
1DR1-TPD4S012DRY	TVS diode	1	U19

1IS1-ADS1015	AD transformer IC	1	U22
1IS1-TLV5614	DA transformer chip	2	U24, U27
1IS1-LM4040B20IDBZT	Patch voltage regulator IC	1	U29
1IS1-TLV320AIC14	CODEC chip	1	U30
1IS1-TDA8541T	Audio power amplifier IC	1	U31
1IS1-MAX3232ESE	Patch dual-channel RS-232 wire driver/receiver IC	1	U32
1IL1-AD8031ARTZ	Patch linear IC	1	U38
1IM1-AT24C08CN-SH	memorizer IC	1	U23
1IS1-XC6209F302PR	Patch voltage stabilization IC	1	U20
1IS1-XC6209F332PR	Patch voltage stabilization IC	1	U5
1IS1-XC6209F502PR	Patch voltage stabilization IC	1	U26
5XT1-MC146-32R76K	Patch ceramic harmonic oscillator	1	Y1
5OC1-24R0-MML-3225	crystal oscillator	1	Y2
5OC1-50R0-MML-3225	crystal oscillator	1	Y3
5XC1-18R4-CEC5032SC H	Patch crystal oscillator	1	Y4
1TF1-ST2301	Patch FET	2	Q7, Q11
5OD1-12R8-AL3-3225	Pressure temperature compensated crystal oscillator	1	Y5
1MR3-MAX-6Q	GPS module	1	U9
2RE1-16-1801	Patch precision resistor	1	R365
2CC1-32-Y5V160-106Z	Flake multi-layer capacitor	2	C243, C237
2CC1-16-C0G500-7R0C	Flake multi-layer capacitor	2	C310, C328
2CC1-16-C0G500-9R0C	Flake multi-layer capacitor	2	C311, C445
2CC1-16-C0G500-150J	Flake multi-layer capacitor	2	C312, C329
2CC1-16-C0G500-240J	Flake multi-layer capacitor	2	C314, C446
2CC1-16-C0G500-390J	Flake multi-layer capacitor	2	C313, C330
2CC1-16-C0G500-820J	Flake multi-layer capacitor	3	C301, C303, C307
2CC1-16-C0G500-121J	Flake multi-layer capacitor	1	C308
2CC1-16-C0G500-151J	Flake multi-layer capacitor	1	C305
2RS1-16-301J	Flake resistor	1	R144
3SE1-SDIP-04	Patch DIP	1	J4
6PM7-4071-HBC	Repeater baseband board PCB	1	

## Table5 Parts List (Front Panel)

Part No.	Accessory Names	Quantity	Location
3CB3-A2548WV-2X05P	Plug-in Board-to-board connector	1	J1
4PE3-0705-F4	Plug-in unit LED	8	LED1, LED2, LED3, LED4, LED5, LED6, LED7, LED9
4PE3-0705-F2	Plug-in unit LED	1	LED8
2CC1-16-Y5V500-104Z	Flake multi-layer capacitor	1	C1
5FE1-BLM18PG181SN1	Patch EMI suppression filter	1	FB1
1TT1-DTC114YE	Patch triode	8	Q1, Q2, Q3, Q4, Q5, Q6, Q7, Q8
2RS1-16-330J	Flake resistor	8	R1, R2, R3, R4, R5, R6, R7, R8
2RS1-16-102J	Flake resistor	1	R16
2RS1-16-101J	Flake resistor	8	R9, R10, R11, R12, R13, R14, R15, R17
6PD7-4071-HFB	Repeater PCB	1	

## Table6 Parts List (Power Board)

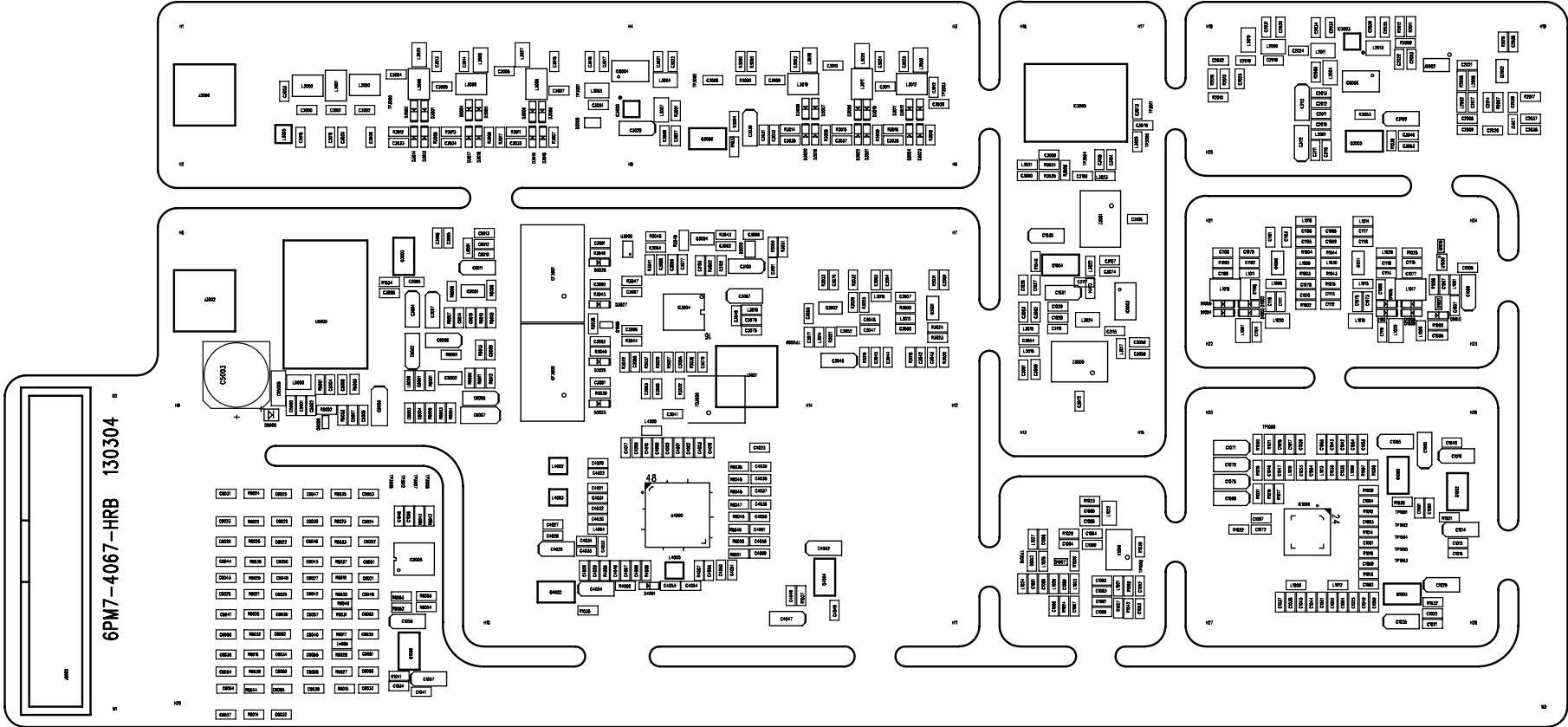
Part No.	Part Name	Quantity	location
2CE3-GM350-102M1320	Plug-in unit aluminum electrolytic capacitor	2	C1, C2
3SJ3-G8P-1C4P-12VDC	Plug-in unit power electric relay	2	U1, U2
3WPC-KF65-4P	Plug-in unit connector terminal	1	J1
3WPC-KF65-2P	Plug-in unit connector terminal	2	J2, J3
3CL3-PH-25402A	Bar connector	2	J4, J5
5FE1-BLM18PG181SN1	Patch EMI suppression filter	1	R1
2RS1-16-471J	Flake resistor	1	R3
1DZ1-LM3Z18VT1G	Patch voltage stabilization diode	1	D1
1DS1-DA2S10100L	Patch switch diode	1	D2
1TT1-MMBT3904	Patch triode	2	Q1, Q2
2RS1-16-103J	Flake resistor	1	R5
2RS1-16-102J	Flake resistor	1	R6
2CC1-16-X7R500-103K	Flake multilayer capacitor	1	C3

6PD7-4071-HWB	STR-U repeater power board PCB	1	
---------------	--------------------------------	---	--

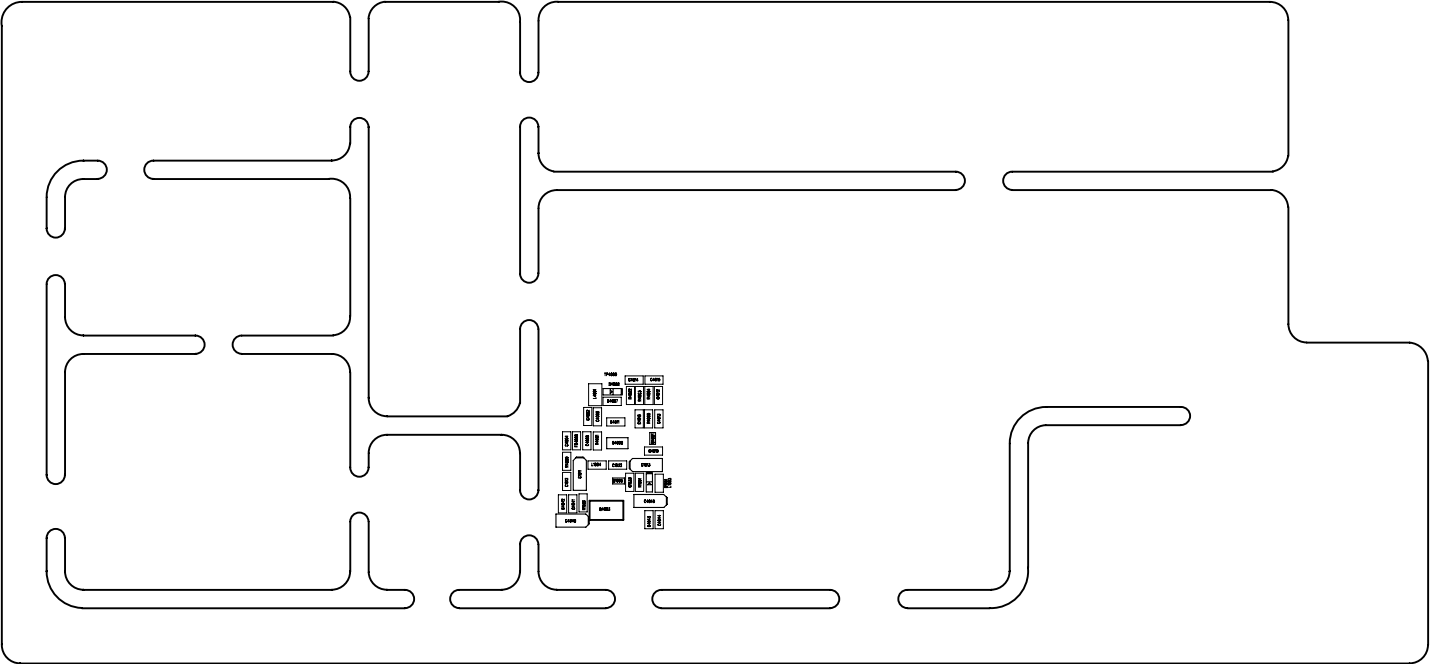
## Table7 Parts List (Accessory Board)

Part No.	Accessory Names	Quantity	Location
3WPC-VGA-26PB	26 pins VGA	1	J9
3CB3-A2548WV-2X13P	Board-to-board connector	1	J10
6PD7-4071-HL1A	STR-U repeater accessory board	1	

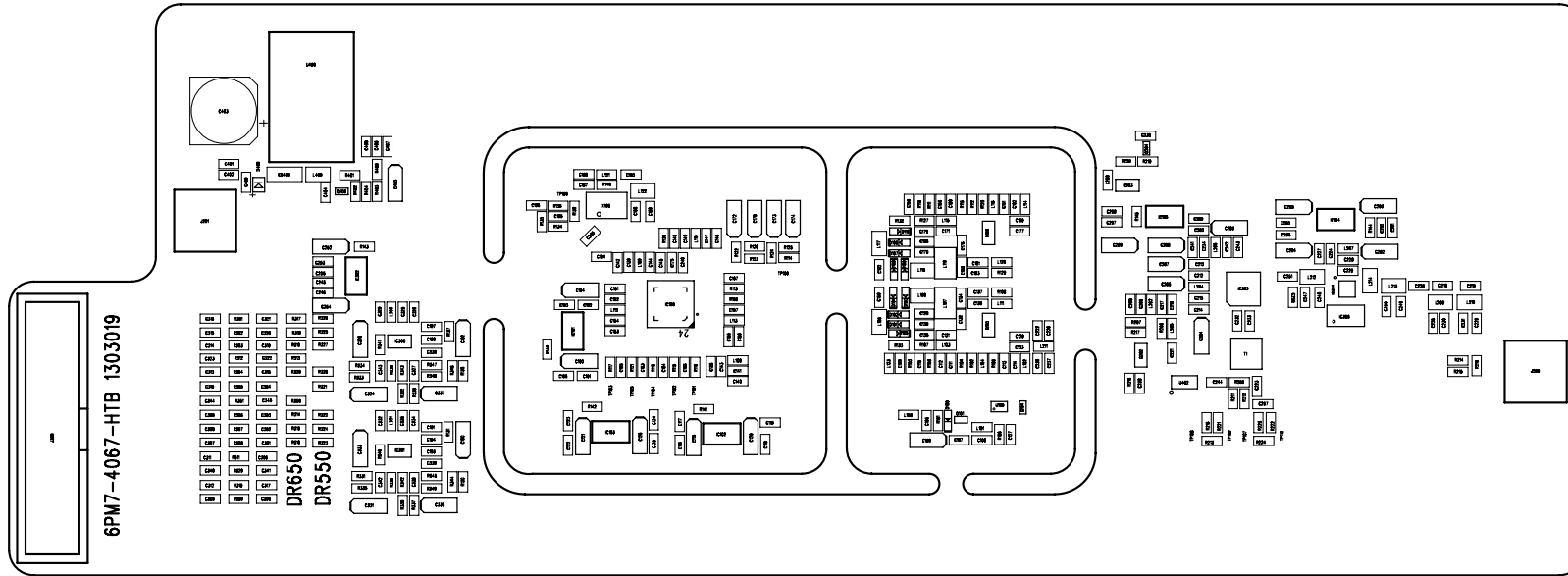
# Figure 1 Rx Module Top Board PCB View



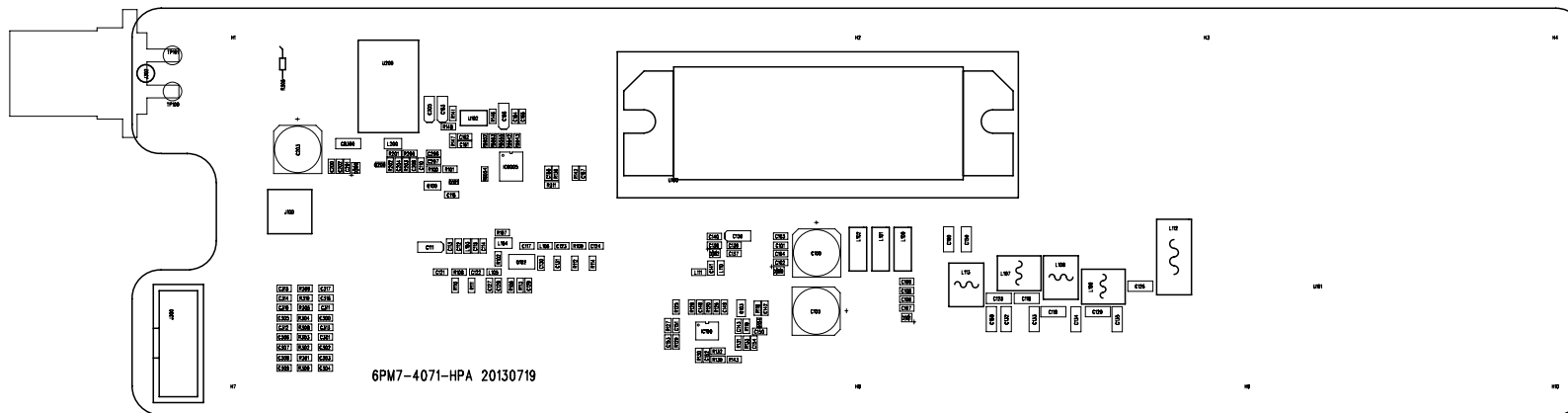
**Figure 2 Rx Module Bottom Board PCB View**



**Figure 3 Tx Module Top Board PCB View**

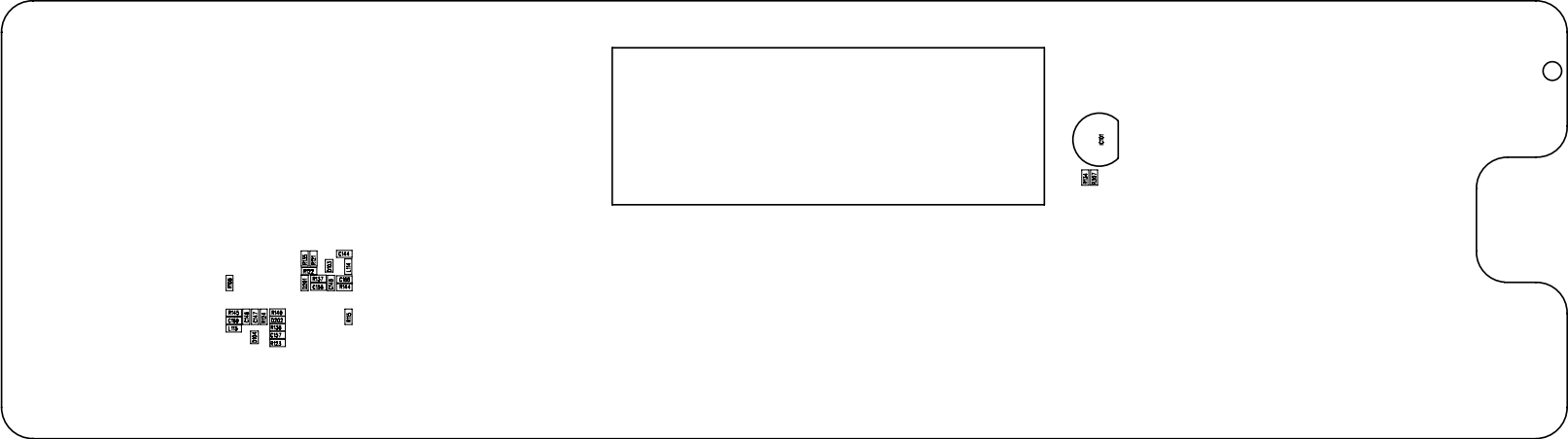


**Figure 4 Power Amplifier Module Top Board PCB View**



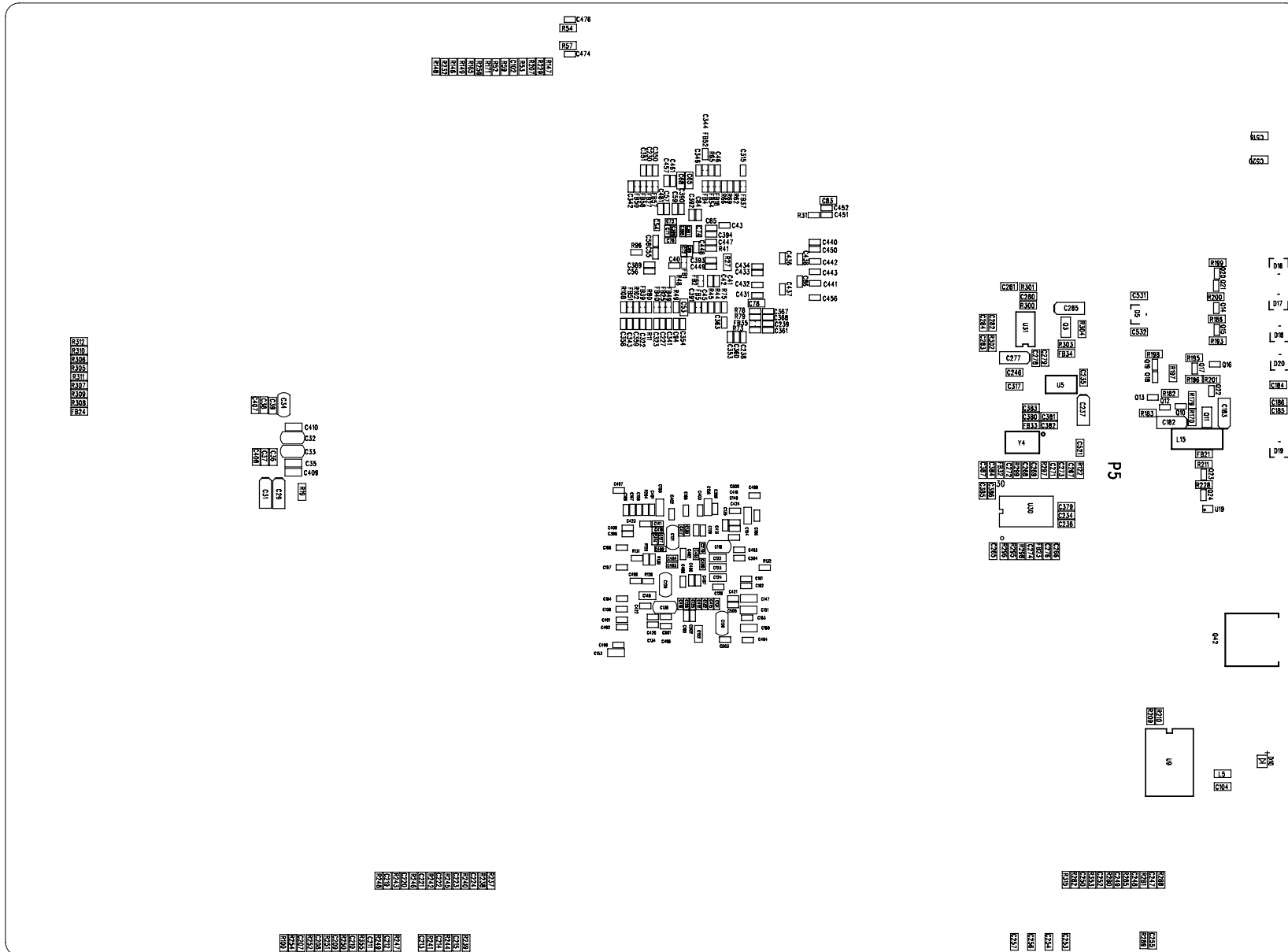


**Figure 5 Power Amplifier Module Bottom Board PCB View**

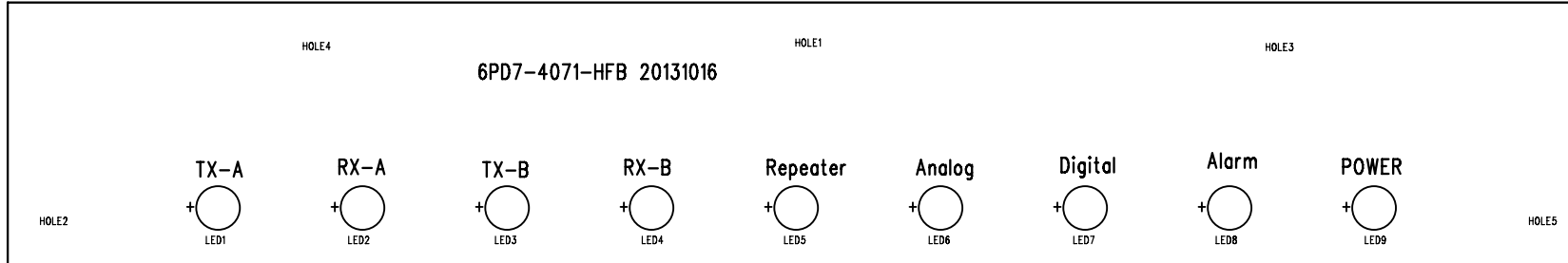




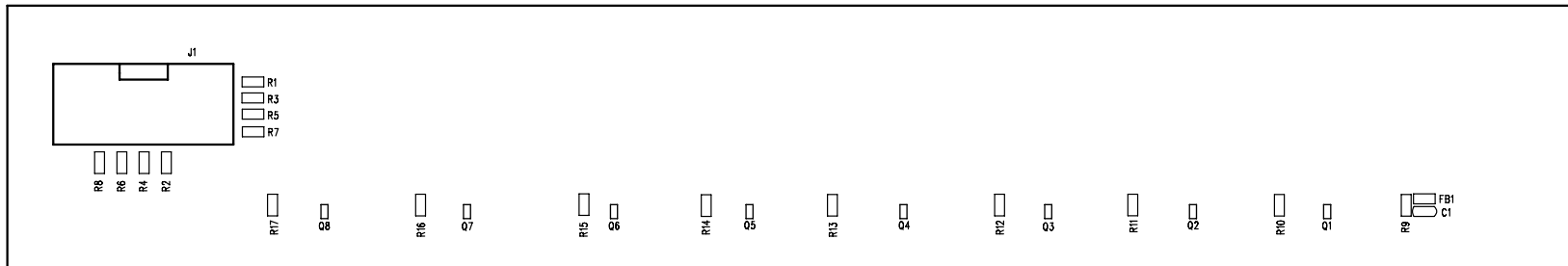
# Figure 7 Baseband Mainboard Bottom Board PCB View



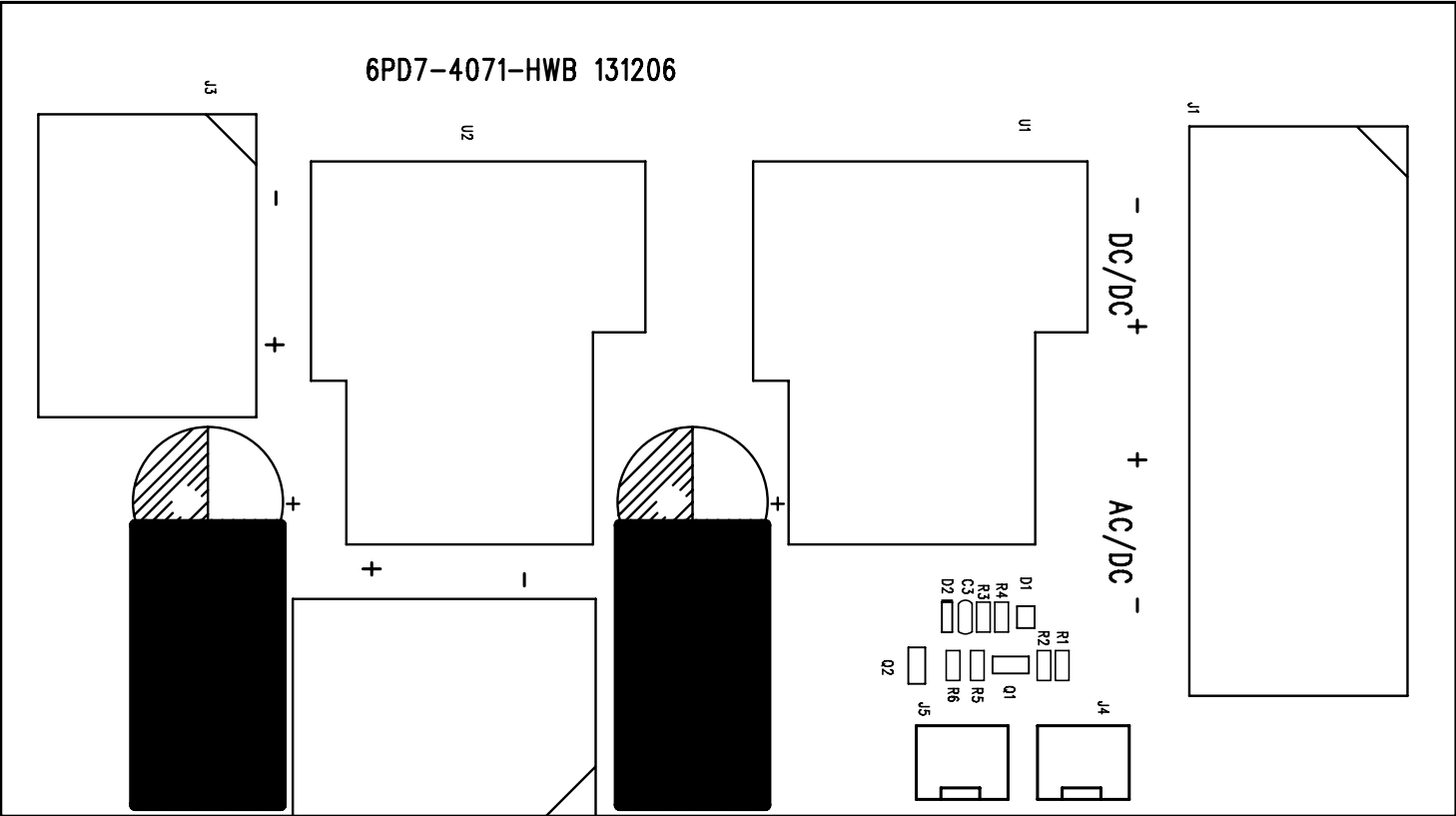
### Figure 8 Front Panel Top Board PCB View



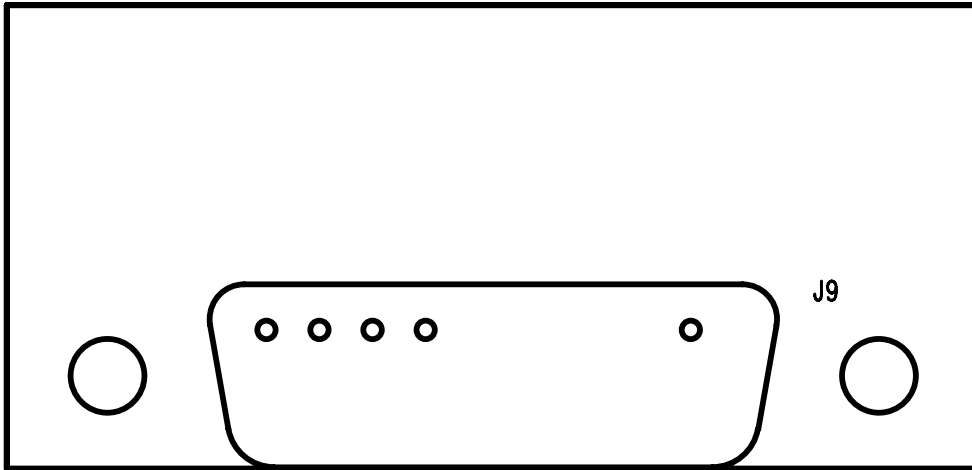
### Figure 9 Front Panel Bottom Board PCB View



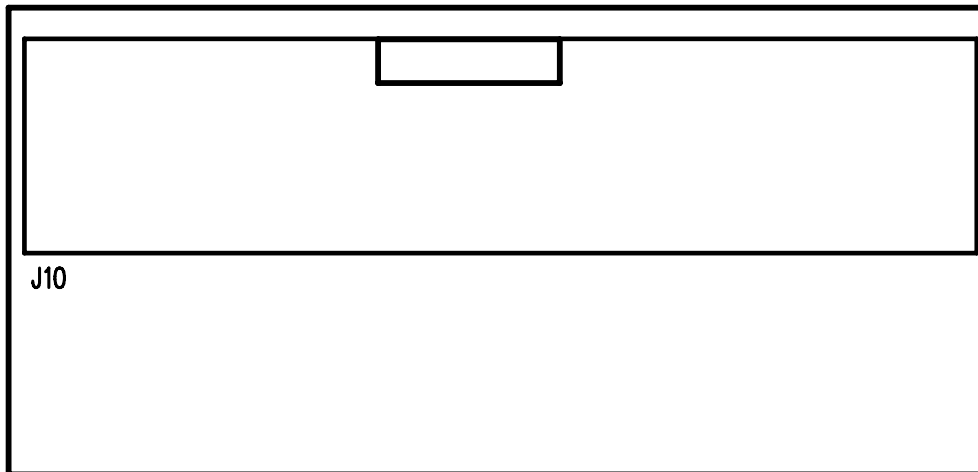
# Figure 10 Power Board Top Board PCB View



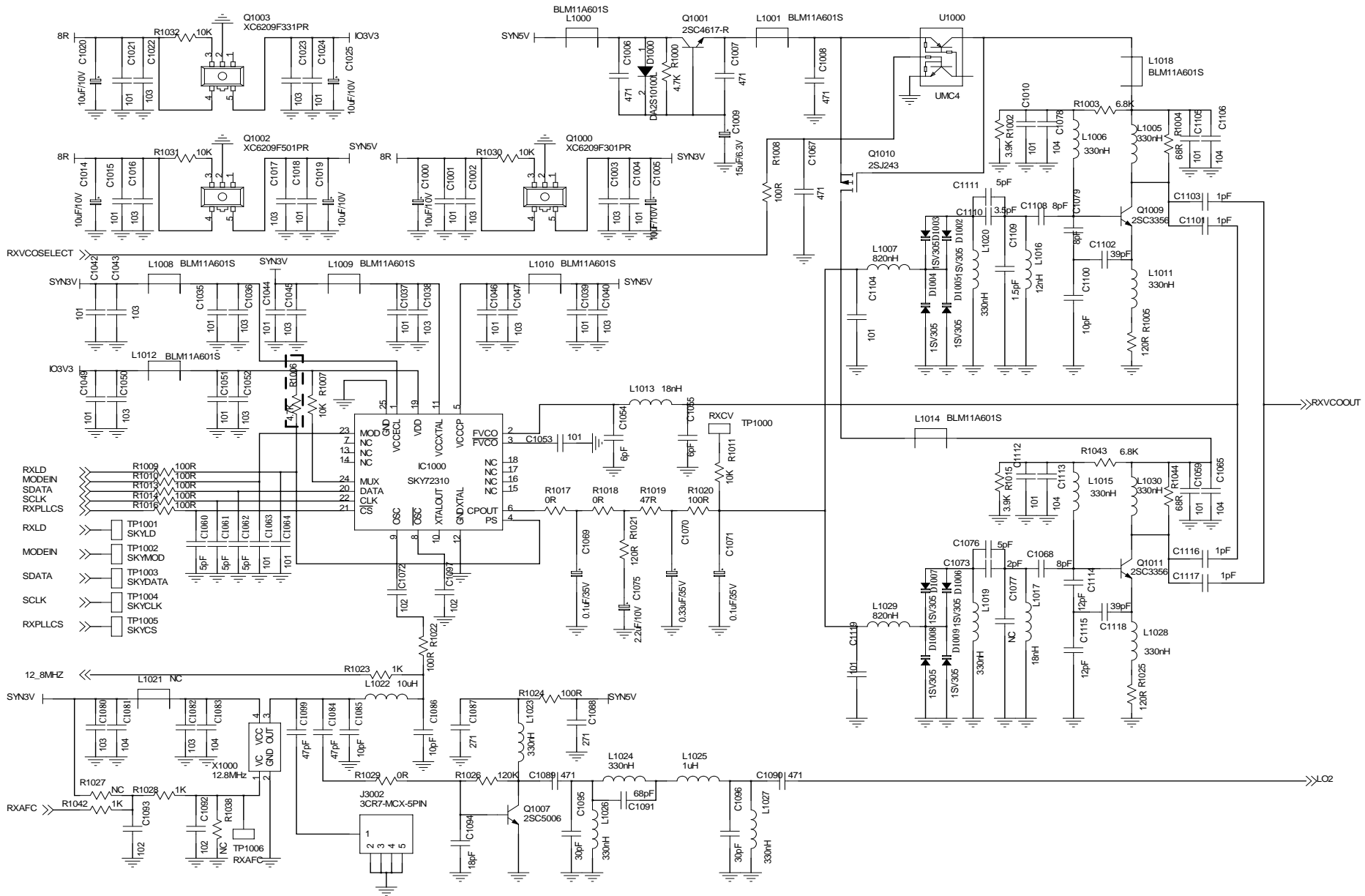
**Figure 11 Accessory Board Top Board PCB View**



**Figure 12 Accessory Board Bottom Board PCB View**



# Figure 13 Rx Module Schematic Diagram

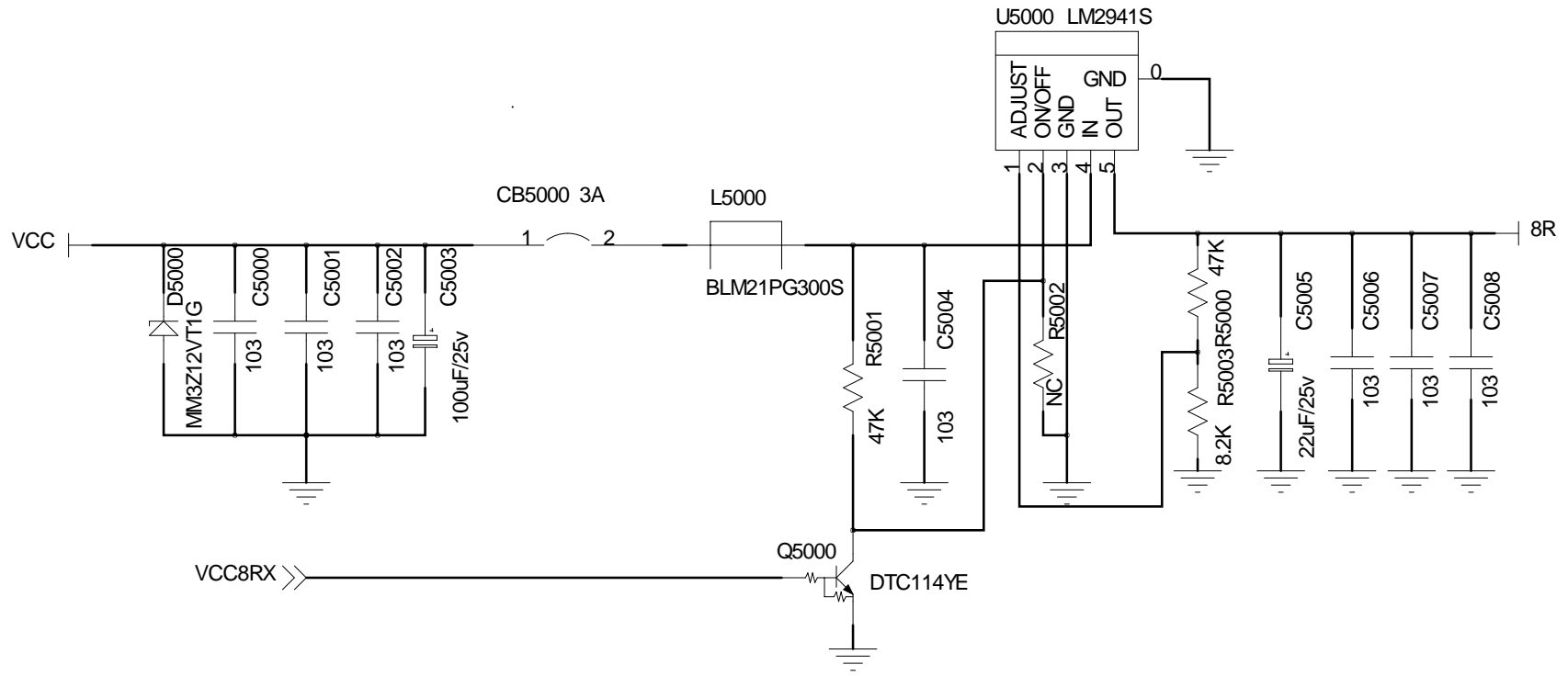


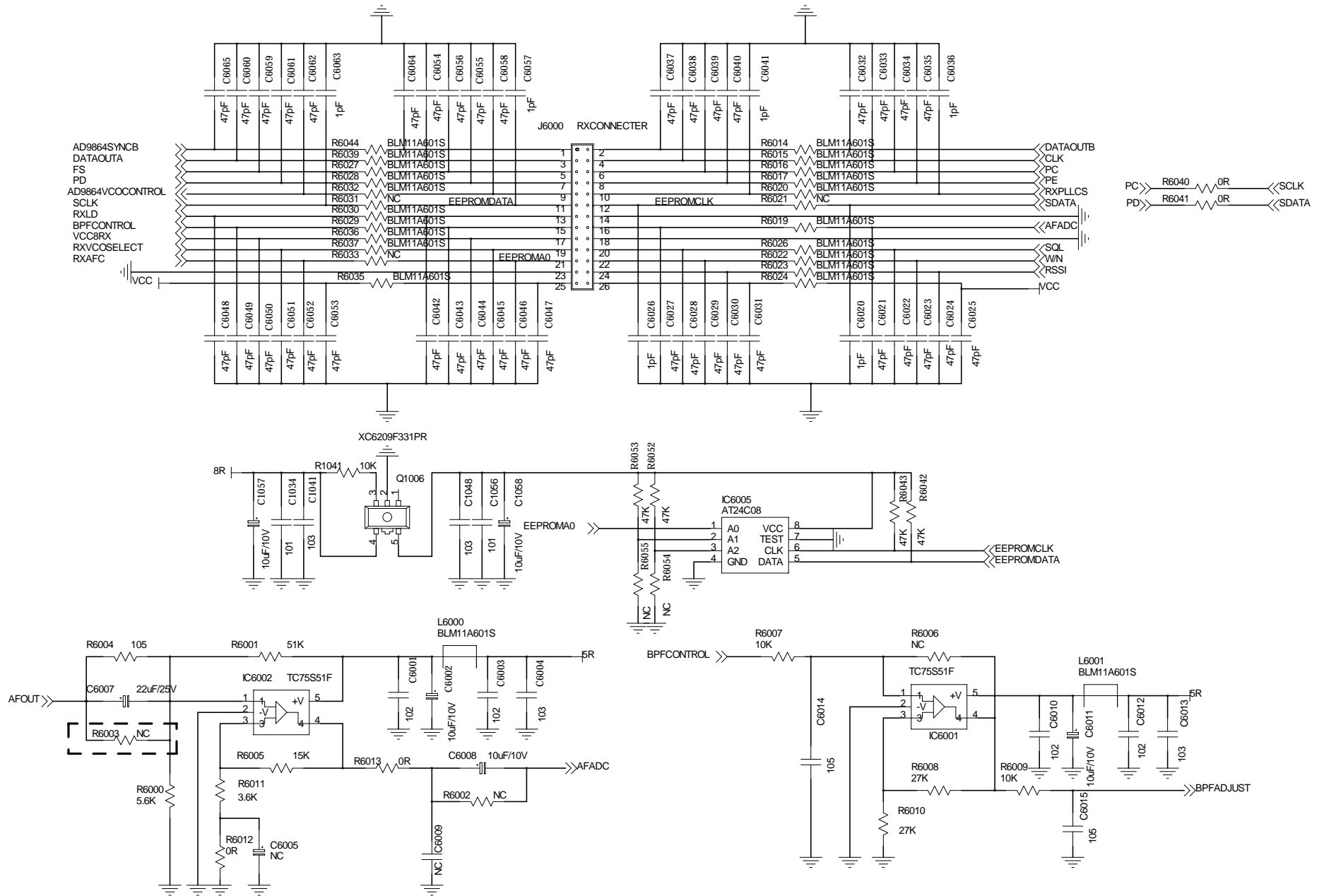


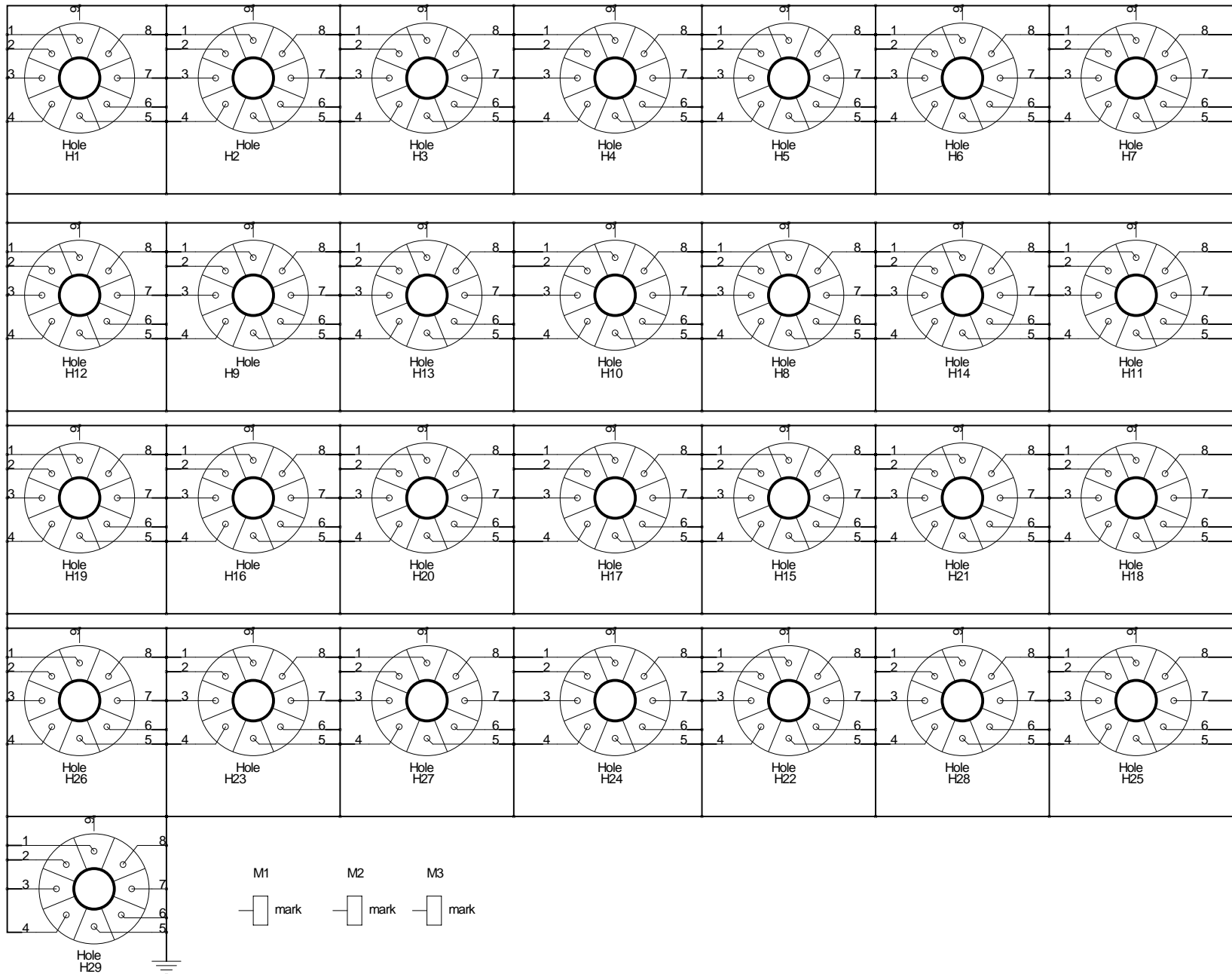




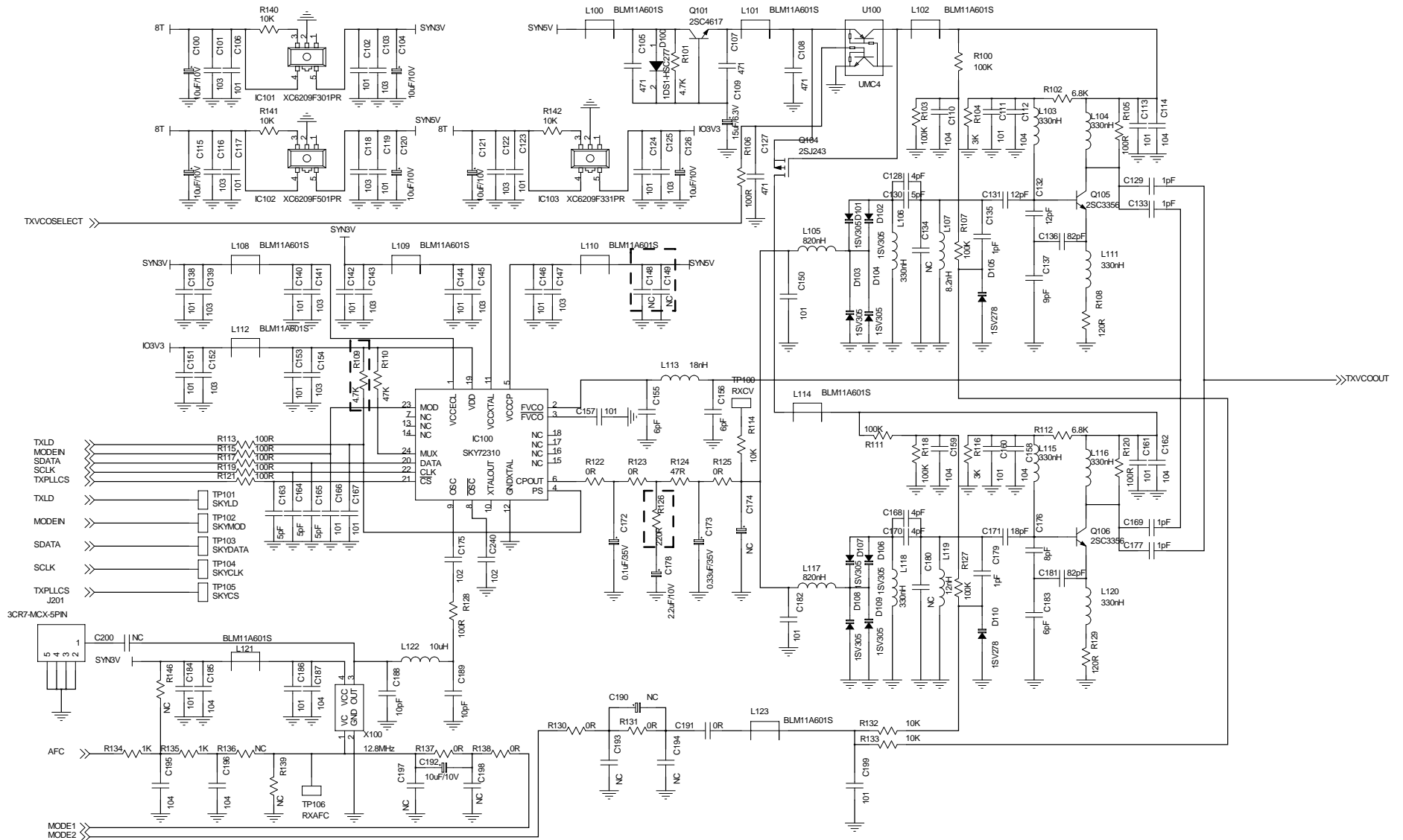


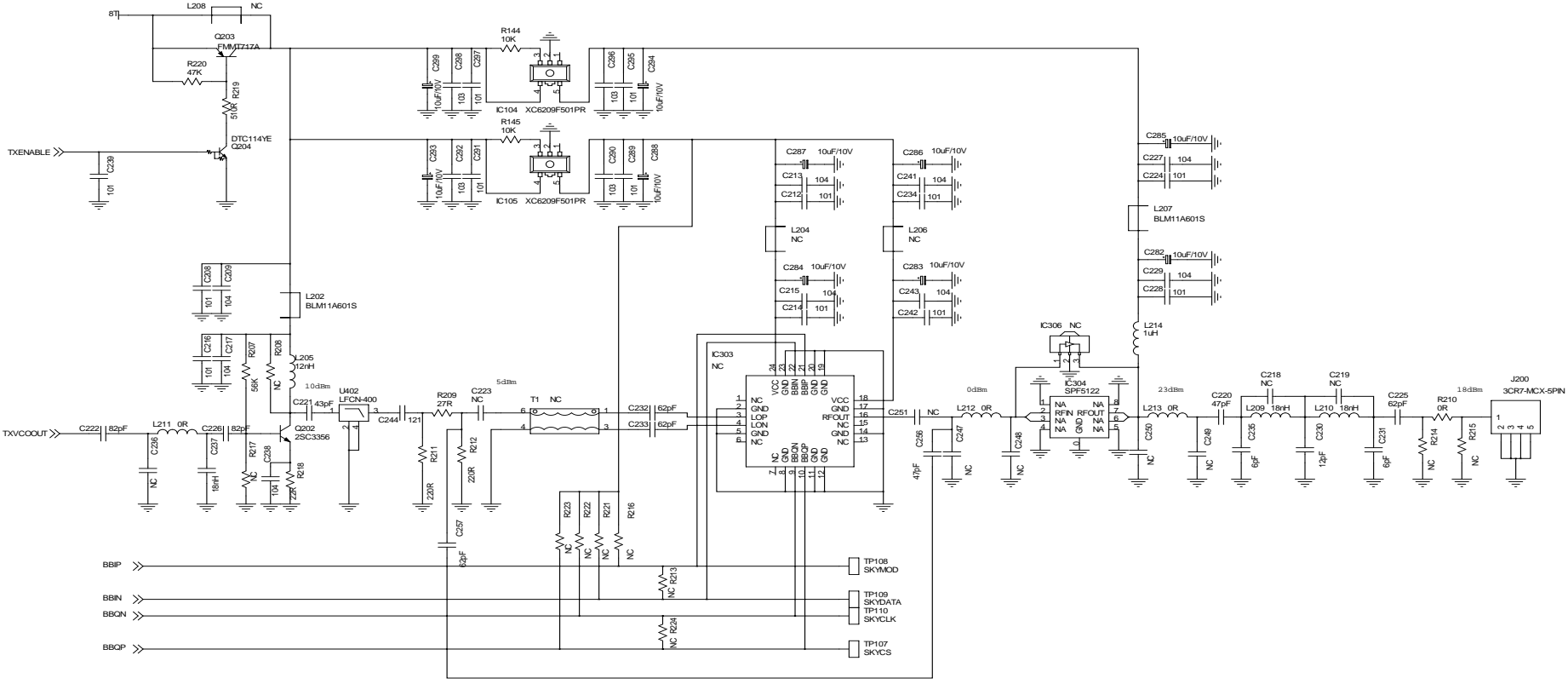


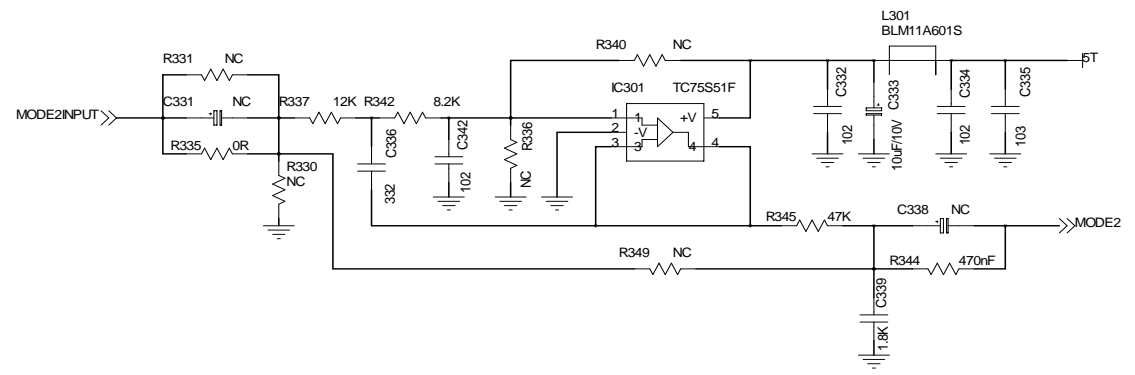
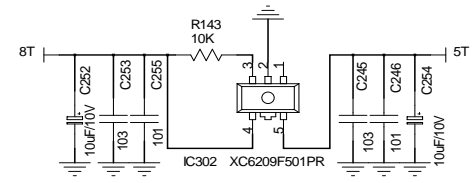
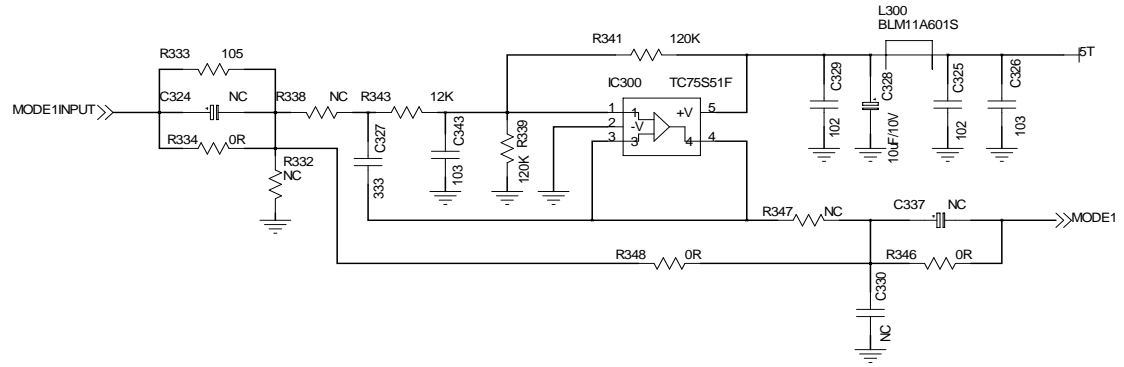
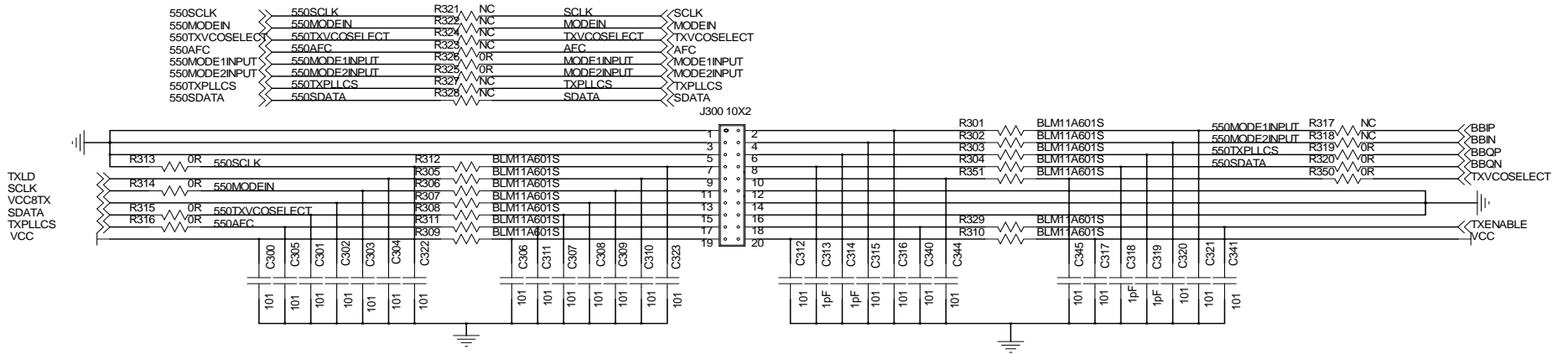




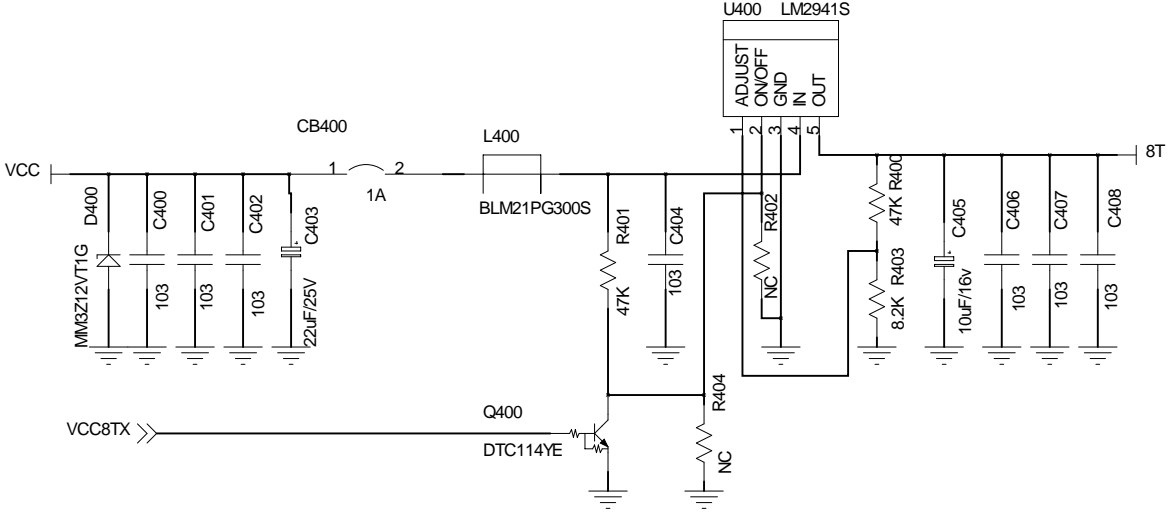
# Figure 14 Tx Module Schematic Diagram

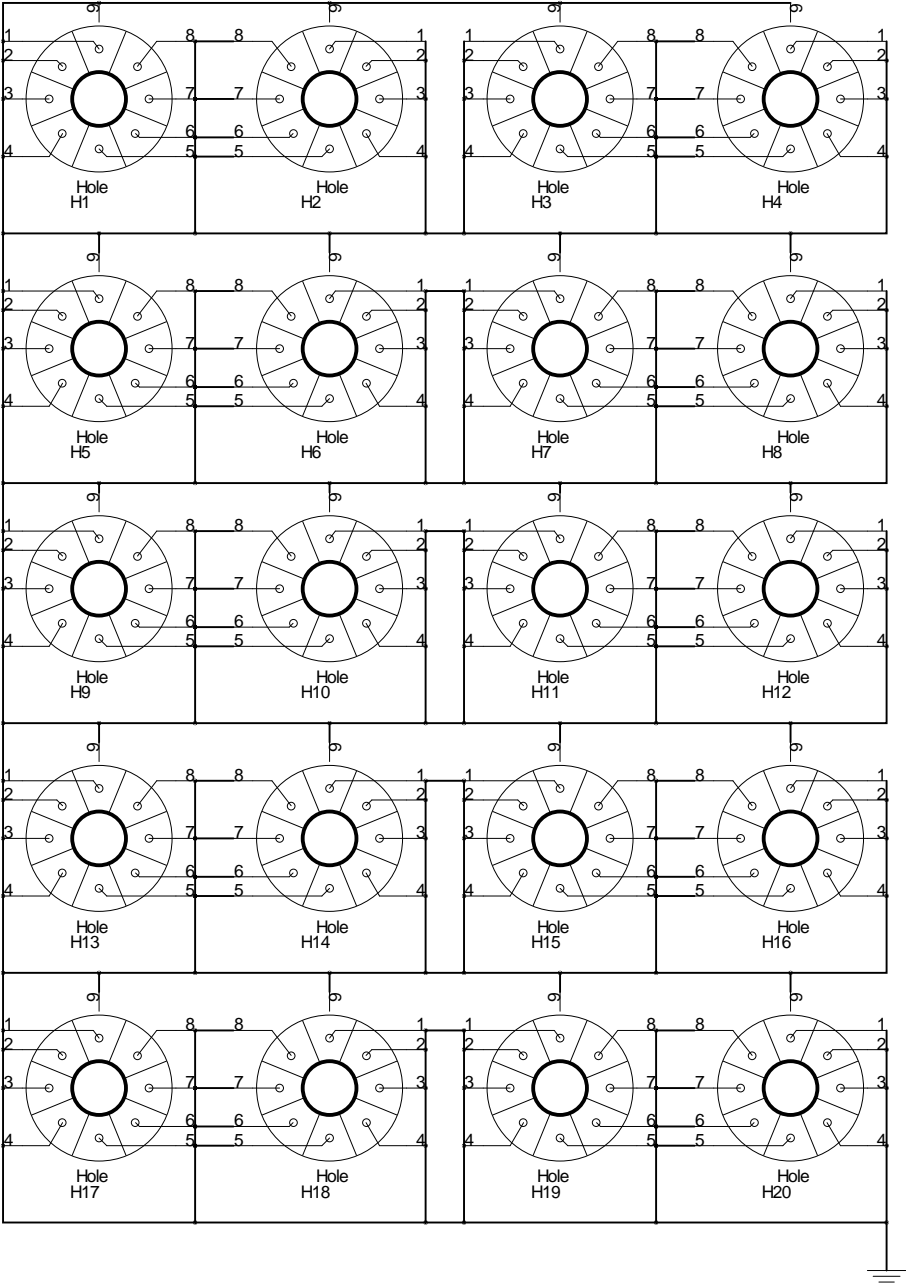






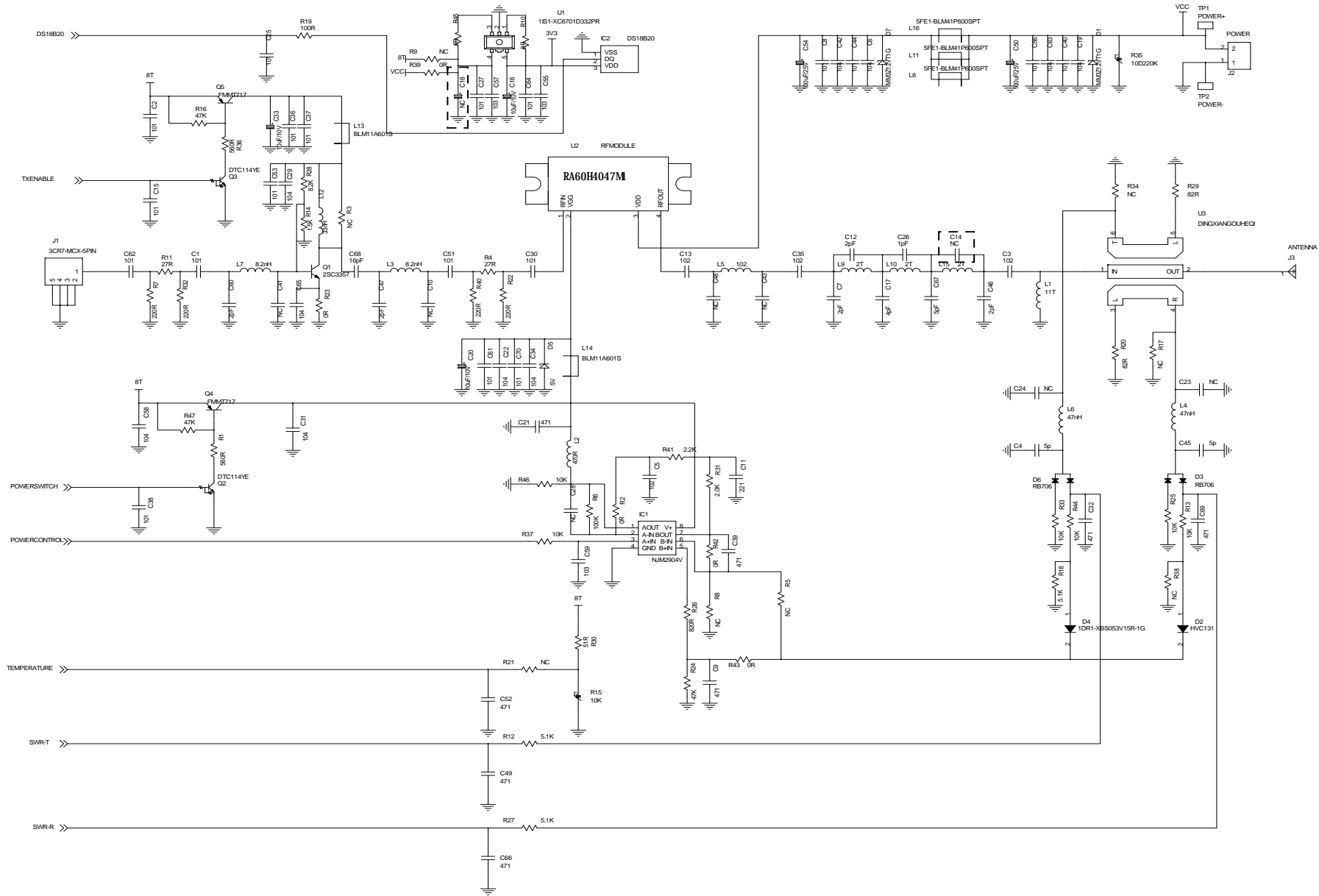


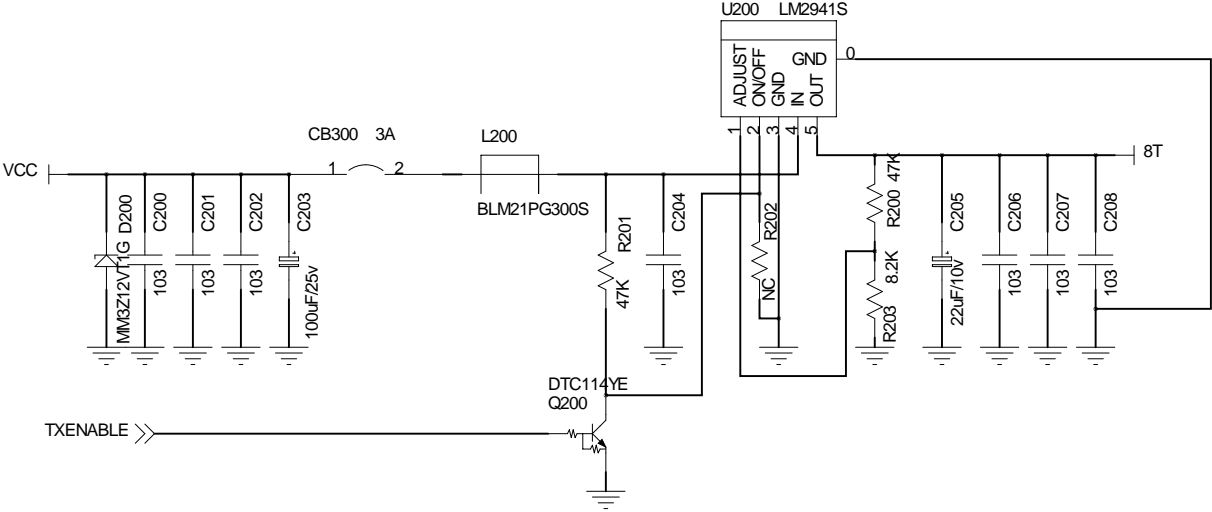




- H21
- MARK H22
- MARK H23
- MARK

# Figure 15 Power Amplifier Module Schematic Diagram





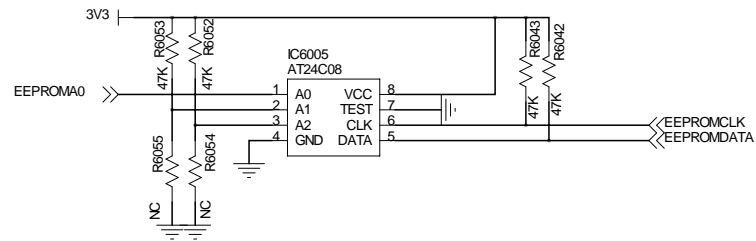
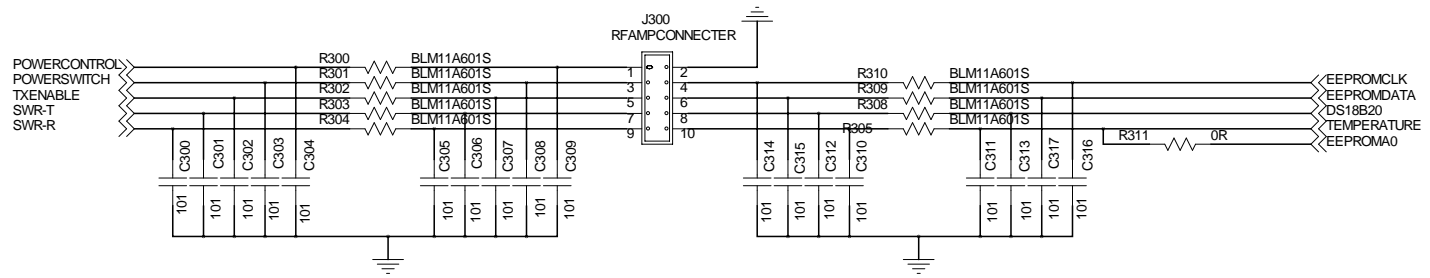
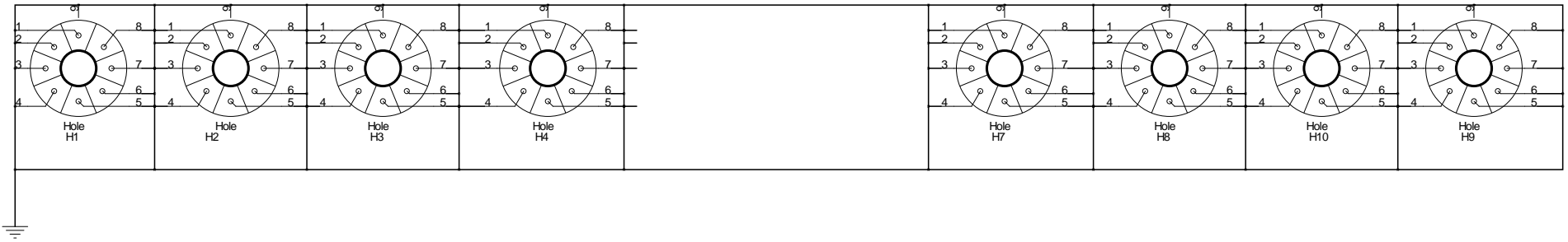
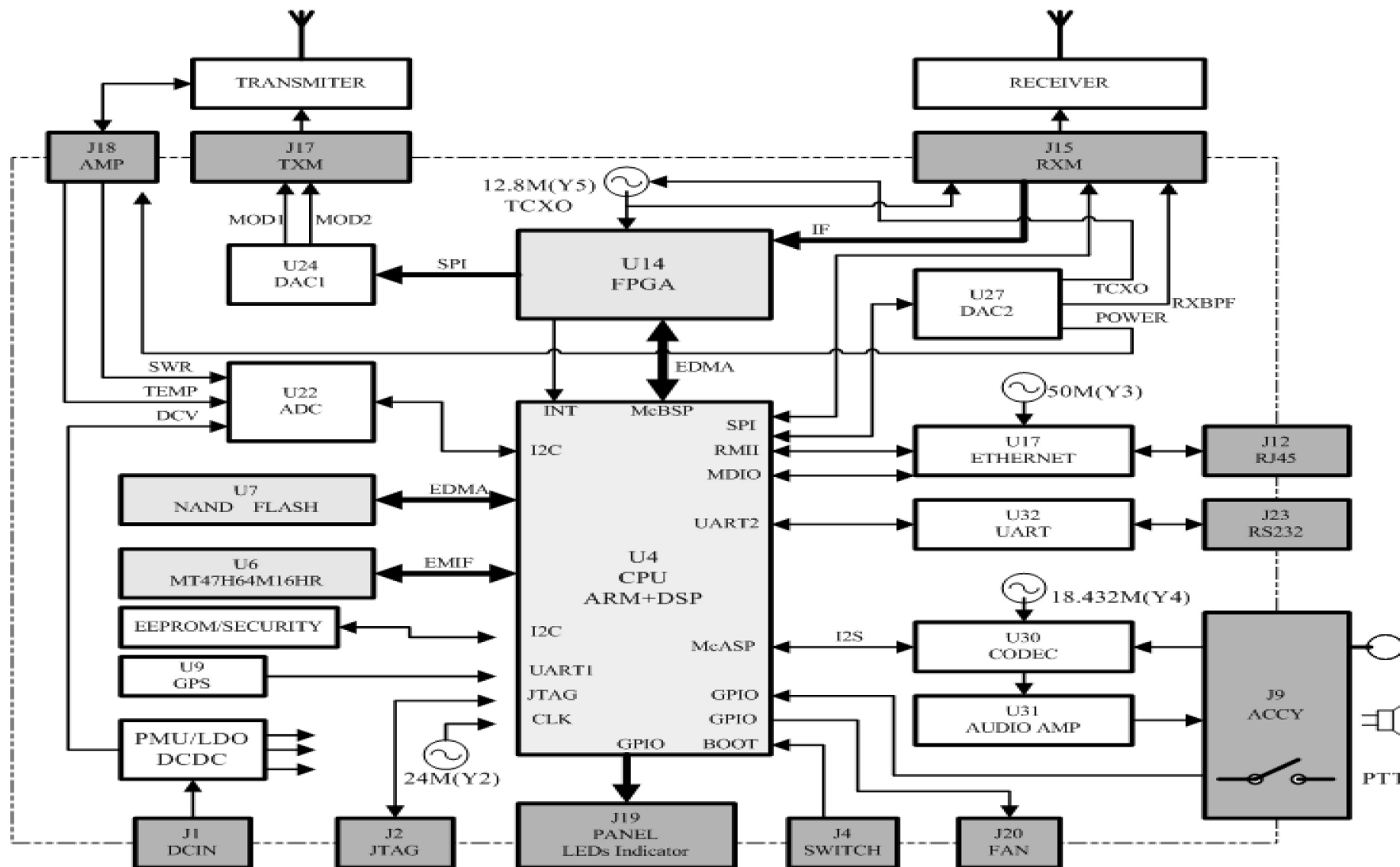
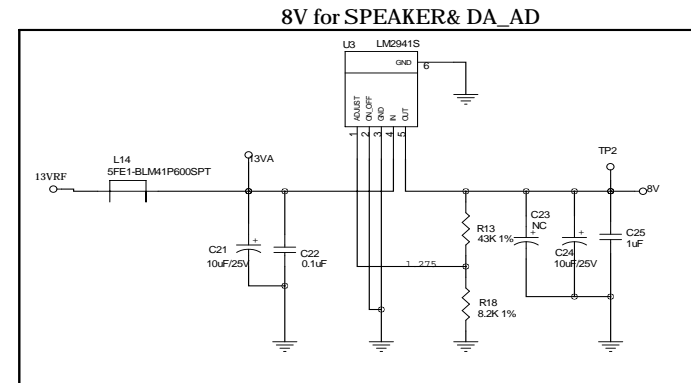
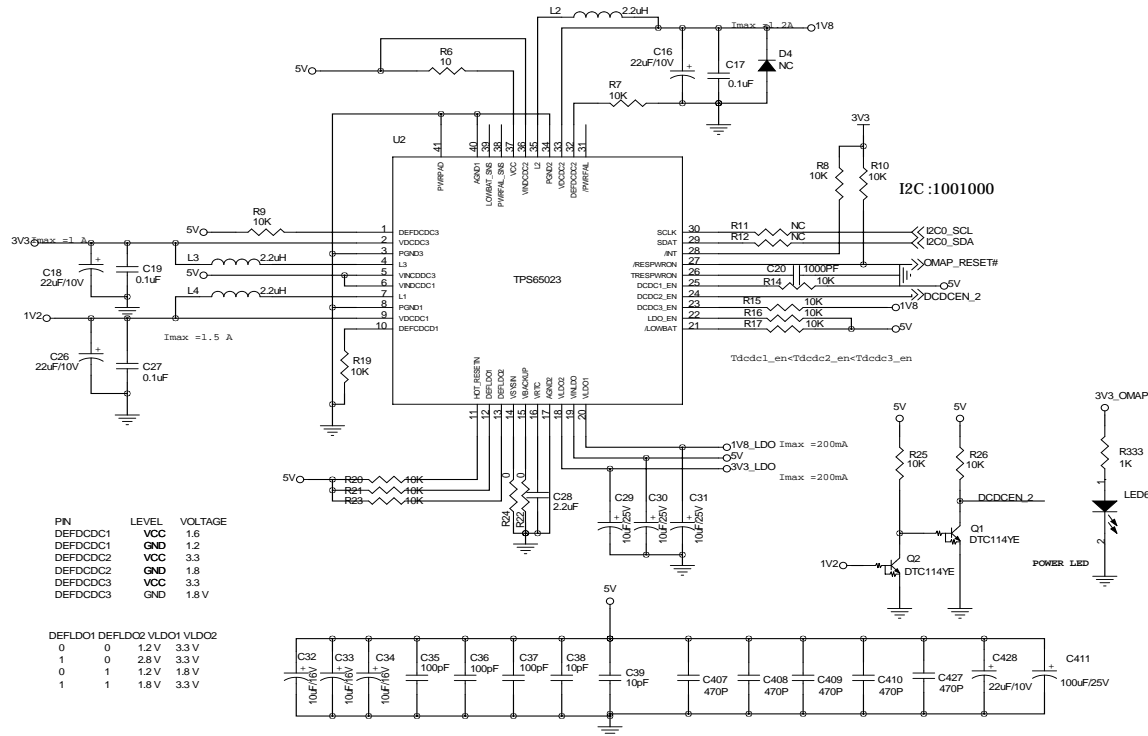
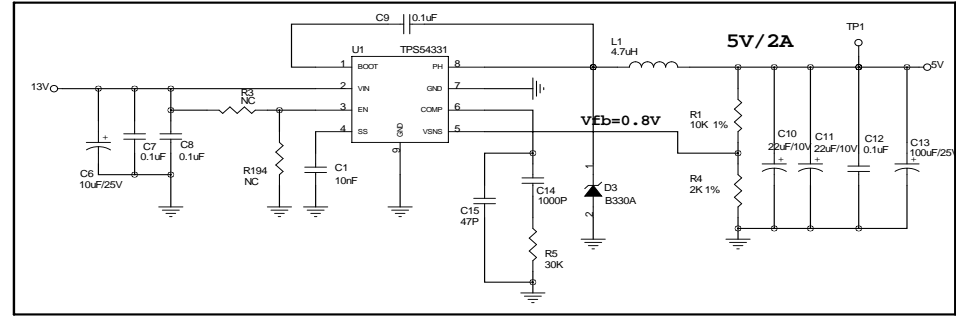
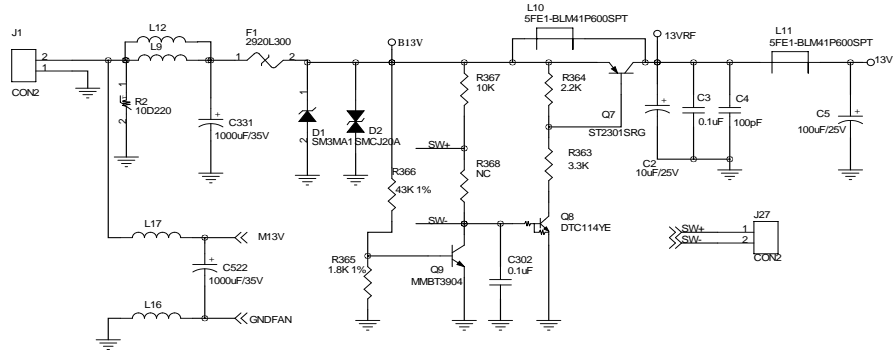


Figure 16 Baseband Mainbaord Schematic Diagram



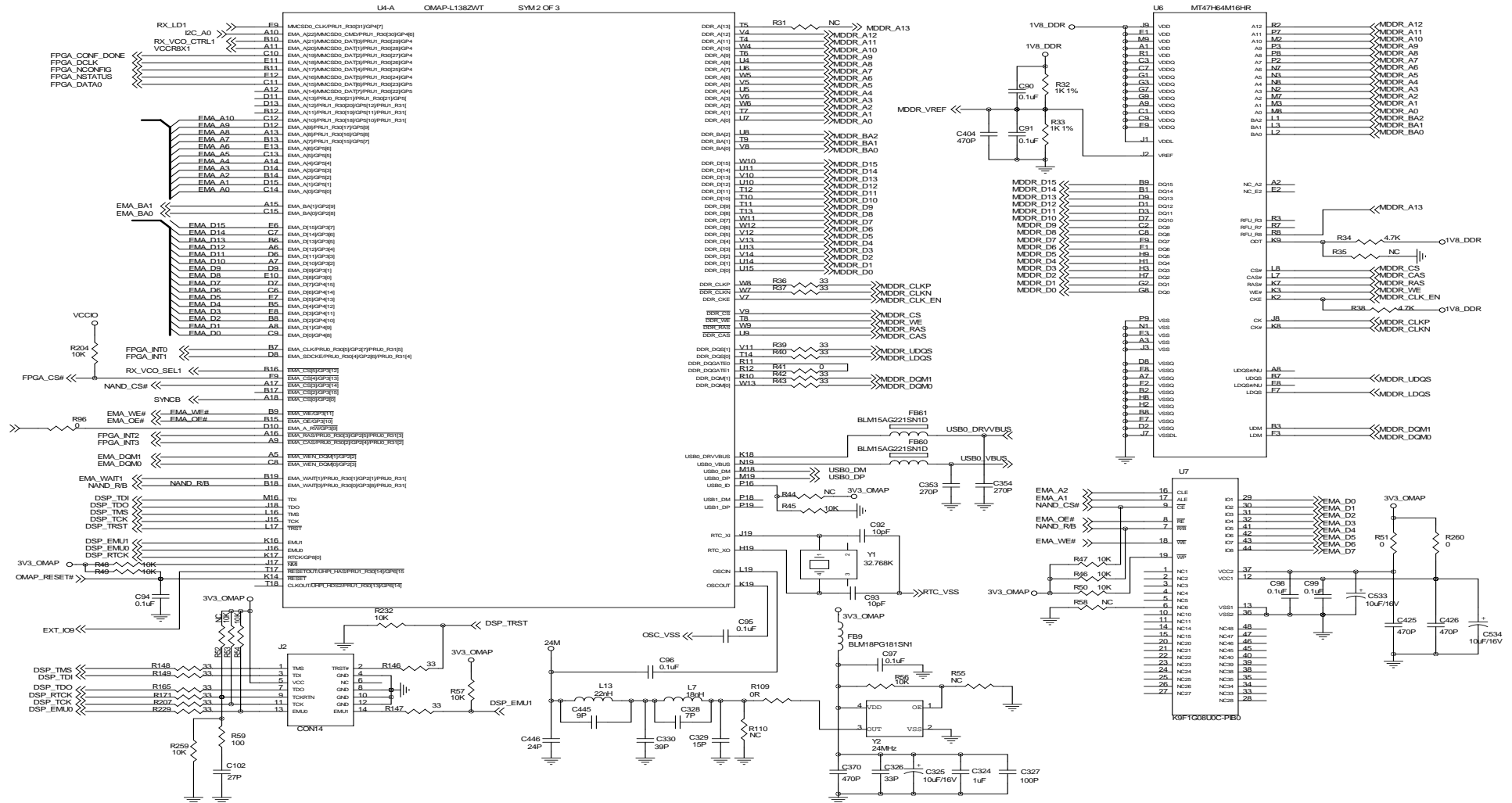


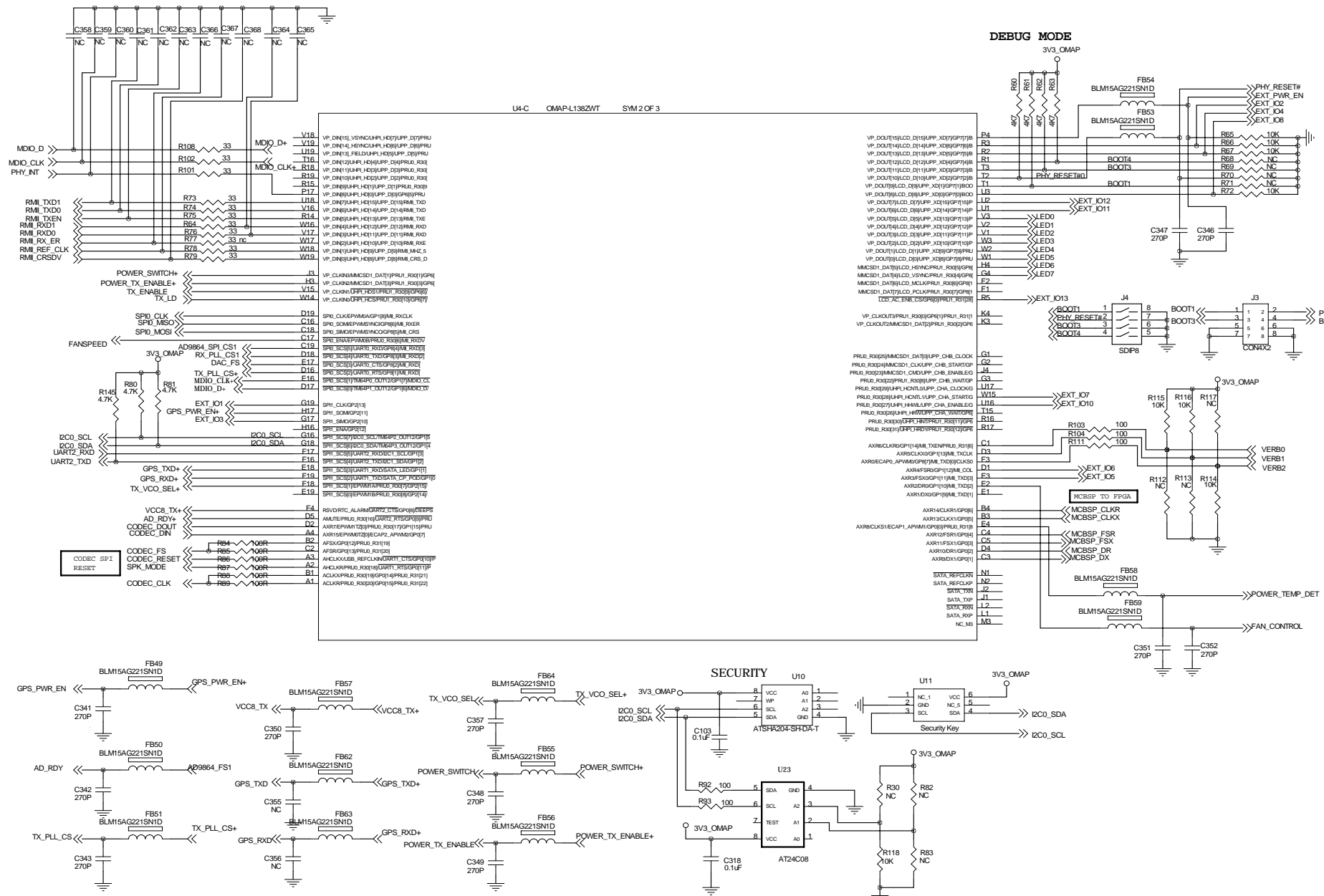
All capacitor not specified is 50V,value tolerance is 20%  
 All resistor not specified value tolerance is 5%

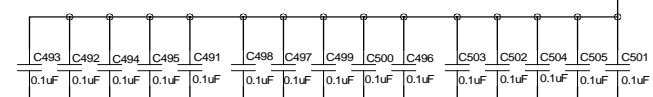
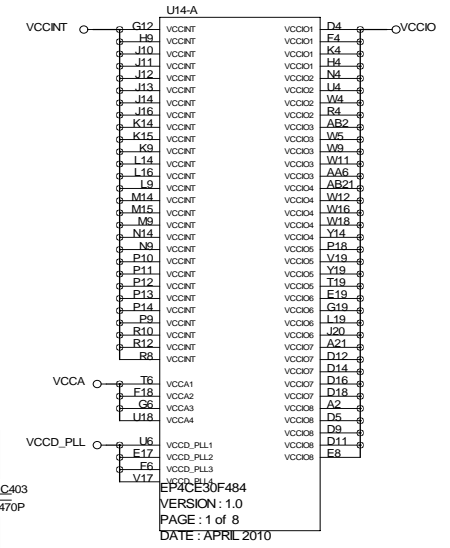
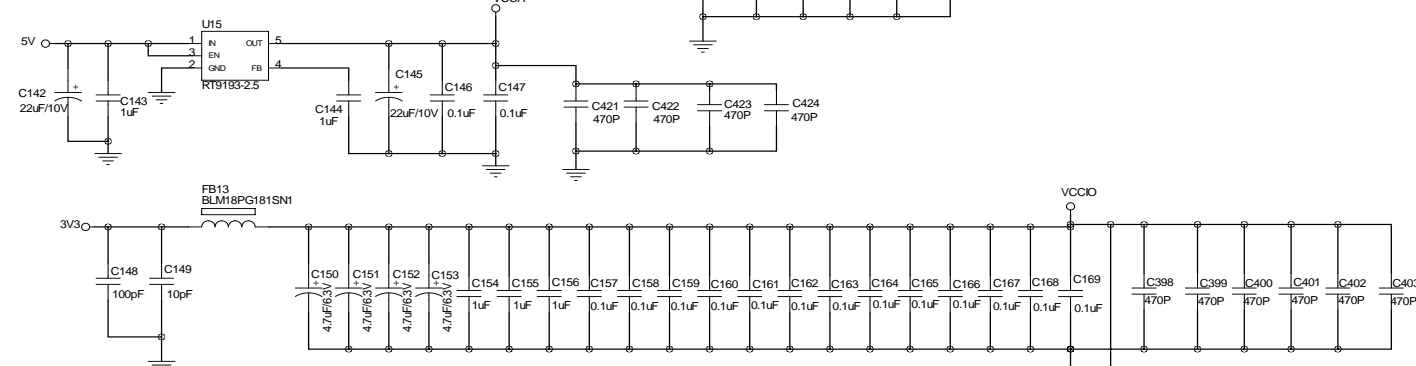
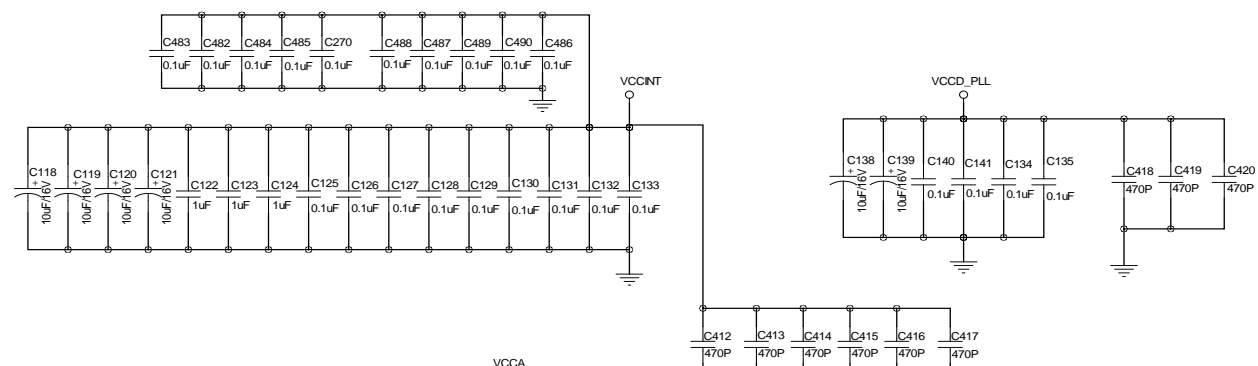
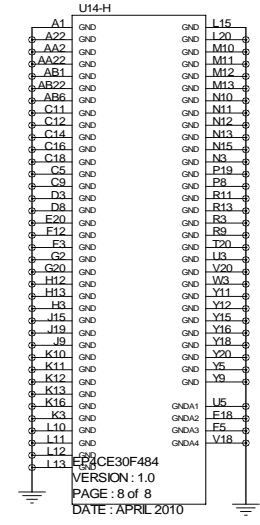
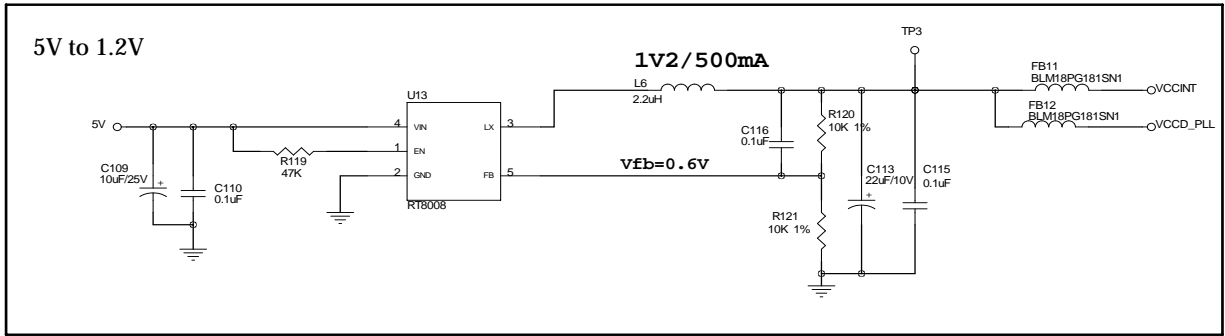


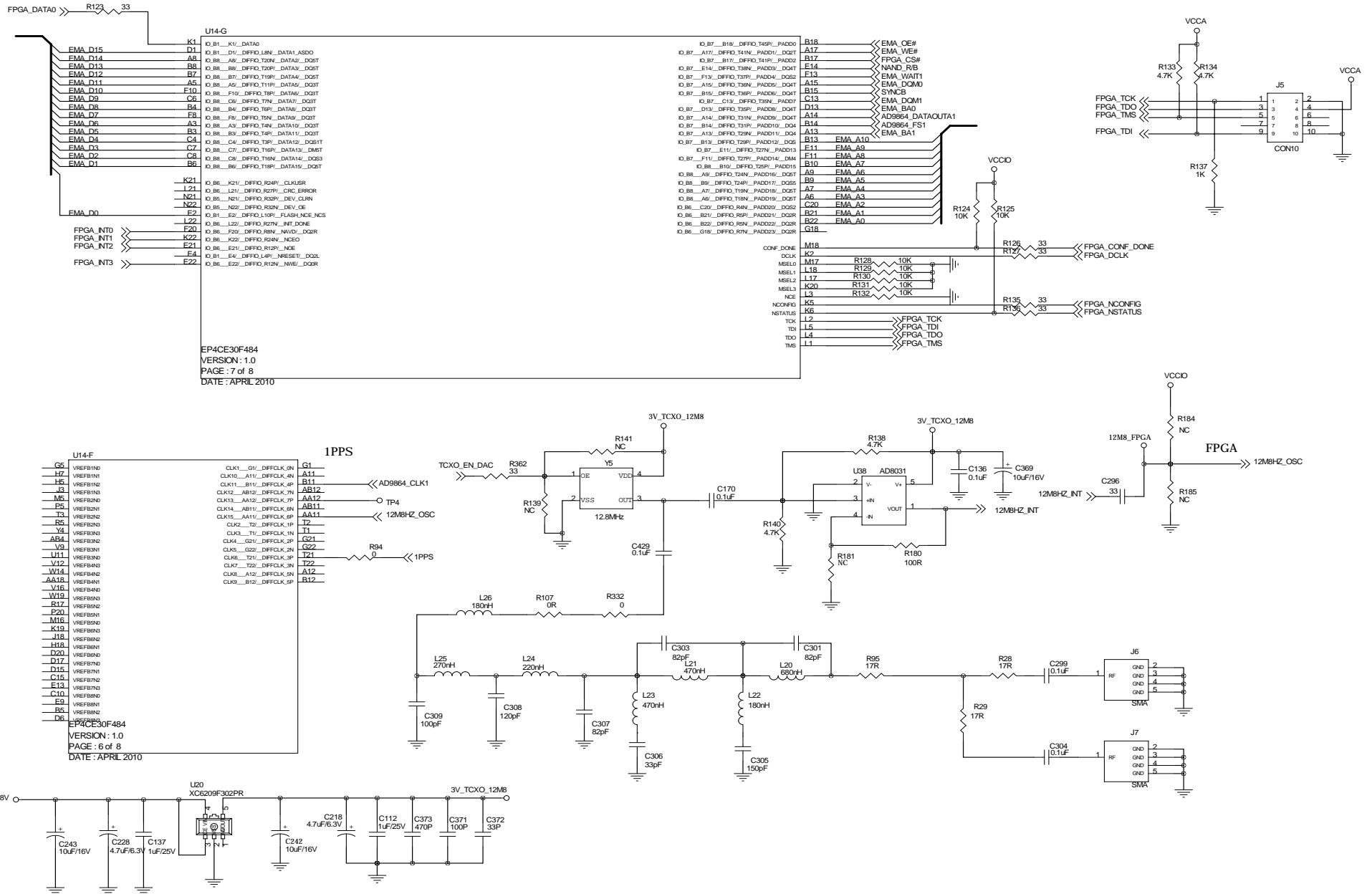


# TR850 Service Manual



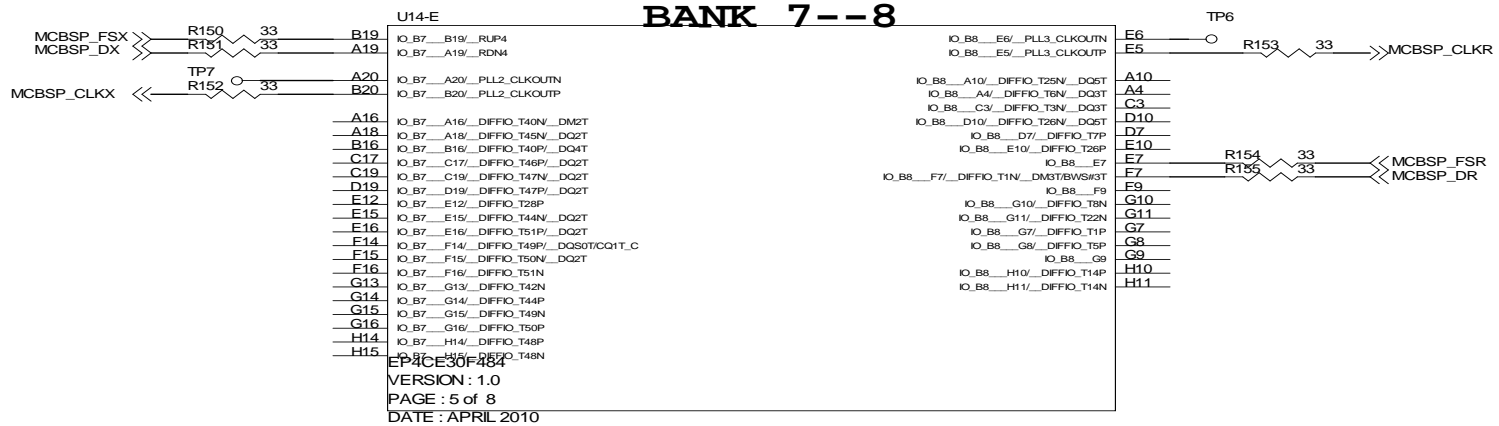
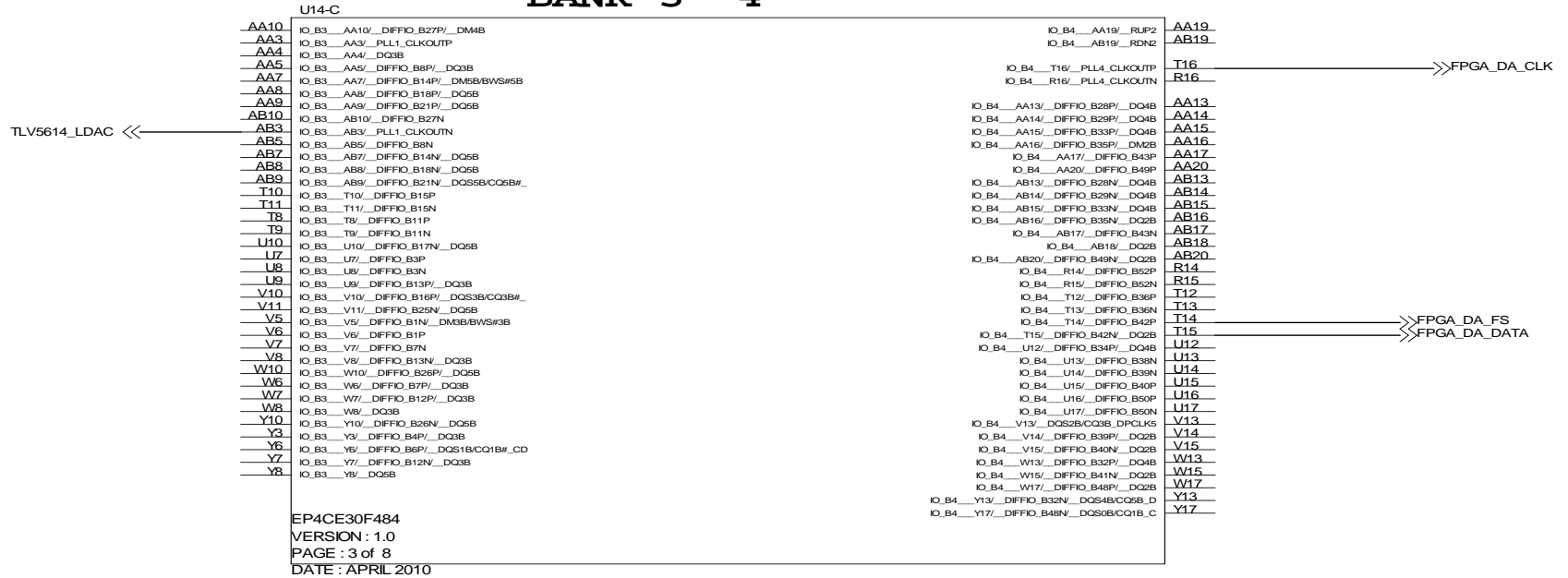






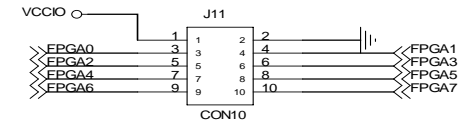
PLL1 used to AD

BANK 3--4



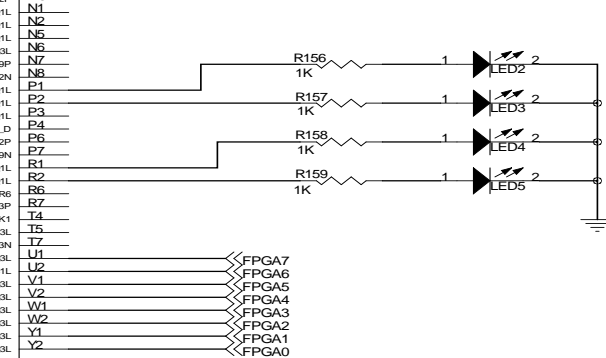
U14-D		BANK 5--6	
T17	IO_B5_T17/_RUP3	IO_B6_C21/_DIFFIO_R6P/_DO2R	C21
T18	IO_B5_T18/_RDN3	IO_B6_C22/_DIFFIO_R6N/_DO2R	C22
AA21	IO_B5_AA21/_DIFFIO_R56P/_DM3R/BWS#3R	IO_B6_D21/_DIFFIO_R5P	D21
M19	IO_B5_M19/_DIFFIO_R30P/_DQ1R	IO_B6_D22/_DIFFIO_R5N/_DM2R	D22
M20	IO_B5_M20/_DIFFIO_R30N/_DQ1R	IO_B6_F17/_DIFFIO_R2N/_DO2R	F17
M21	IO_B5_M21/_DIFFIO_R31P/_DQ1R	IO_B6_F19/_DIFFIO_R8P/_DO2R	F19
M22	IO_B5_M22/_DIFFIO_R31N/_DQ1R	IO_B6_F21/_DIFFIO_R18P/_DO2R	F21
N16	IO_B5_N16/_DIFFIO_R40P	IO_B6_F22/_DIFFIO_R18N/_DO2R	F22
N17	IO_B5_N17/_DIFFIO_R33N	IO_B6_G17/_DIFFIO_R2P	G17
N18	IO_B5_N18/_DIFFIO_R33P/_DQ51R/CQ1R#	IO_B6_H16/_DIFFIO_R10P	H16
N19	IO_B5_N19/_DIFFIO_R36P	IO_B6_H17/_DIFFIO_R7P	H17
N20	IO_B5_N20/_DIFFIO_R36N/_DQ1R	IO_B6_H19/_DIFFIO_R13P/_DO2R	H19
P15	IO_B5_P15/_DIFFIO_R46N	IO_B6_H20/_DIFFIO_R19N/_DO2R	H20
P16	IO_B5_P16/_DIFFIO_R46P	IO_B6_H21/_DIFFIO_R22P/_DO2R	H21
P17	IO_B5_P17	IO_B6_H22/_DIFFIO_R22N/_DO2R	H22
P21	IO_B5_P21/_DIFFIO_R38P/_DQ1R	IO_B6_J17/_DIFFIO_R10N	J17
P22	IO_B5_P22/_DIFFIO_R38N/_DQ1R	IO_B6_J21/_DIFFIO_R23P/_DM2R	J21
R18	IO_B5_R18/_DIFFIO_R42N	IO_B6_J22/_DIFFIO_R23N/_DQ53R/CQ1R_D	J22
R19	IO_B5_R19/_DIFFIO_R42P/_DM1R/BWS#1R	IO_B6_K17/_DIFFIO_R20N	K17
R20	IO_B5_R20/_DIFFIO_R44N/_DQ3R	IO_B6_K18/_DIFFIO_R20P/_DO2R	K18
R21	IO_B5_R21/_DIFFIO_R39P/_DQ1R		
R22	IO_B5_R22/_DIFFIO_R39N/_DQ1R		
U19	IO_B5_U19/_DIFFIO_R50P		
U20	IO_B5_U20/_DIFFIO_R50N/_DQ3R		
U21	IO_B5_U21/_DIFFIO_R43P/_DQ3R		
U22	IO_B5_U22/_DIFFIO_R43N/_DQ3R		
V21	IO_B5_V21/_DIFFIO_R45P/_DQ3R		
V22	IO_B5_V22/_DIFFIO_R45N/_DQ3R		
W20	IO_B5_W20/_DQ53R/CQ3R#_CDPCLK4		
W21	IO_B5_W21/_DIFFIO_R48P/_DQ3R		
W22	IO_B5_W22/_DIFFIO_R48N/_DQ3R		
Y21	IO_B5_Y21/_DIFFIO_R51P		
Y22	IO_B5_Y22/_DIFFIO_R51N/_DQ3R		

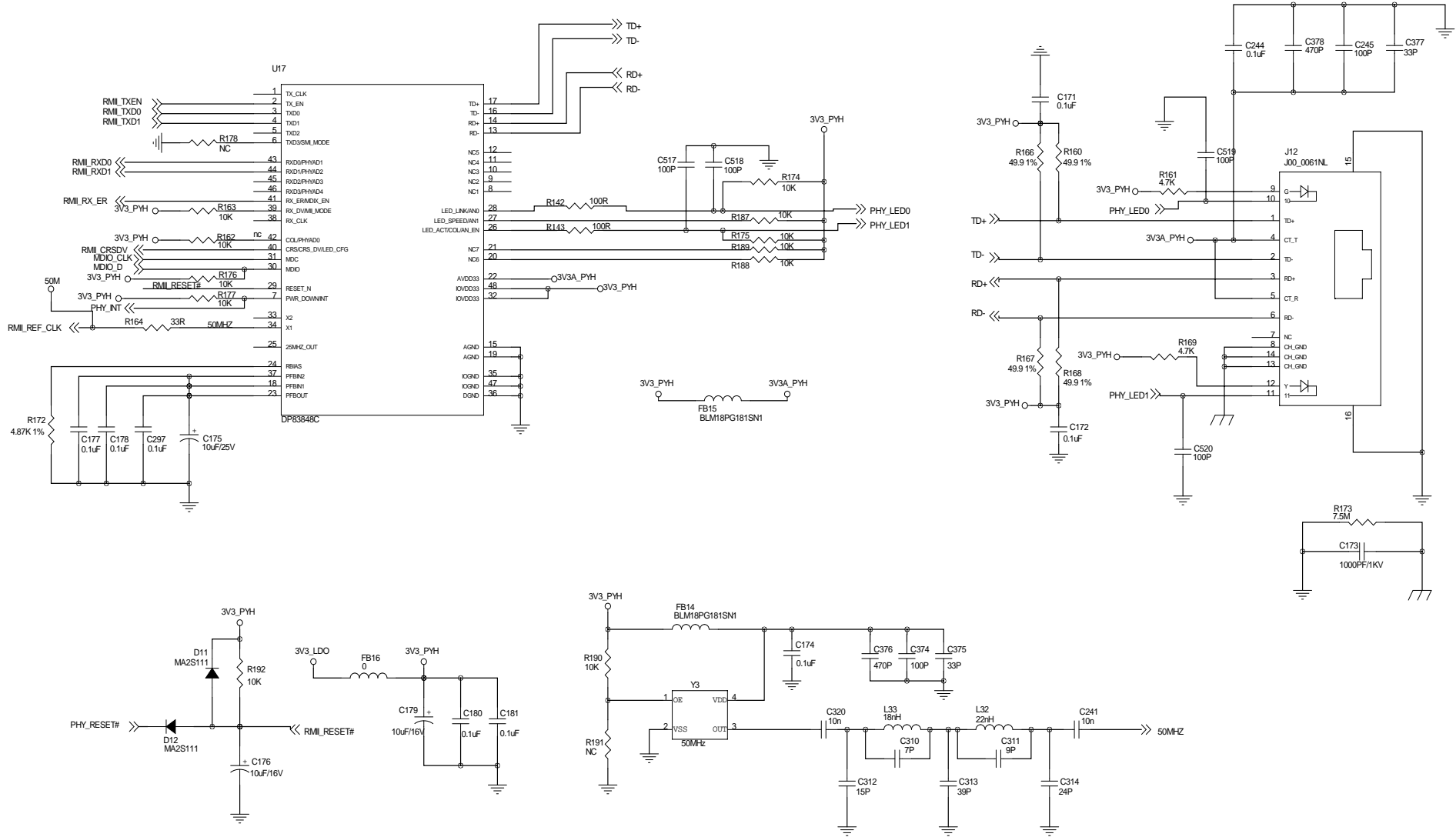
EP4CE30F484  
 VERSION : 1.0  
 PAGE : 4 of 8  
 DATE : APRIL 2010

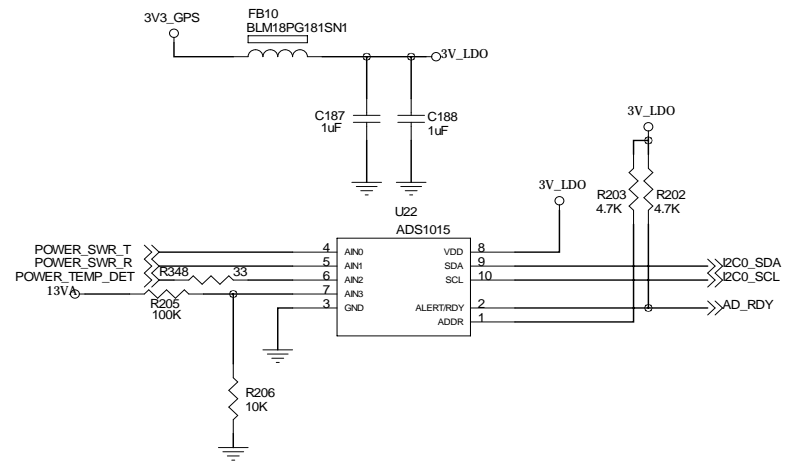
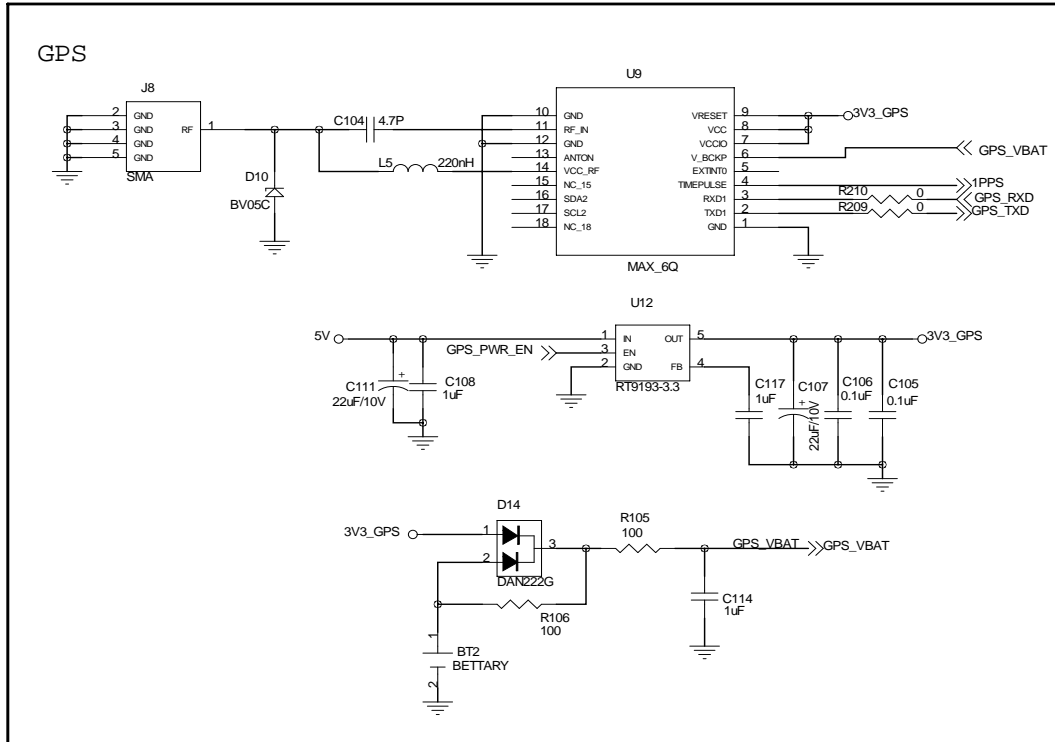


U14-B		BANK 1--2	
B1	IO_B1_B1/_DIFFIO_L2N/_DQ2L	IO_B2_V4/_RUP1	V4
B2	IO_B1_B2/_DIFFIO_L2P/_DQ2L	IO_B2_V3/_RDN1	V3
C1	IO_B1_C1/_DIFFIO_L7N/_DQ2L	IO_B2_AA1/_DIFFIO_L50N/_DQ3L	AA1
C2	IO_B1_C2/_DIFFIO_L7P/_DQ52L/CQ3L_CDP	IO_B2_L6/_DIFFIO_L26P/_DO0L	L6
D2	IO_B1_D2/_DIFFIO_L8P/_DQ2L	IO_B2_L7/_DIFFIO_L30N	L7
E1	IO_B1_E1/_DIFFIO_L10N	IO_B2_M1/_DIFFIO_L27N	M1
E3	IO_B1_E3/_DIFFIO_L4N/_DQ2L	IO_B2_M2/_DIFFIO_L27P/_DO0L	M2
F1	IO_B1_F1/_DIFFIO_L12N/_DO0L	IO_B2_M3/_DIFFIO_L28N/_DO1L	M3
F2	IO_B1_F2/_DIFFIO_L12P/_DM2L	IO_B2_M4/_DIFFIO_L28P/_DM0L	M4
G3	IO_B1_G3/_DIFFIO_L1N	IO_B2_M6/_DIFFIO_L26N/_DO0L	M6
G4	IO_B1_G4/_DIFFIO_L1P	IO_B2_M7/_DIFFIO_L41N	M7
H1	IO_B1_H1/_DIFFIO_L23N/_DO0L	IO_B2_M8/_DIFFIO_L42P	M8
H2	IO_B1_H2/_DIFFIO_L23P/_DO0L	IO_B2_N1/_DIFFIO_L29N/_DO1L	N1
H6	IO_B1_H6/_DIFFIO_L9P/_DQ2L	IO_B2_N2/_DIFFIO_L29P/_DO1L	N2
H8	IO_B1_H8/_DIFFIO_L14P	IO_B2_N5/_DO1L	N5
J1	IO_B1_J1/_DIFFIO_L24N/_DO0L	IO_B2_N6/_DIFFIO_L41P/_DO3L	N6
J2	IO_B1_J2/_DIFFIO_L24P/_DO0L	IO_B2_N7/_DIFFIO_L48P	N7
J4	IO_B1_J4/_DQ50L/CQ1L_DPCLK0	IO_B2_N8/_DIFFIO_L42N	N8
J5	IO_B1_J5/_DIFFIO_L18N	IO_B2_P1/_DIFFIO_L32N/_DO1L	P1
J6	IO_B1_J6/_DIFFIO_L19N/_DQ2L	IO_B2_P2/_DIFFIO_L32P/_DO1L	P2
J7	IO_B1_J7/_DIFFIO_L21P	IO_B2_P3/_DIFFIO_L34N/_DO1L	P3
J8	IO_B1_J8/_DIFFIO_L14N	IO_B2_P4/_DIFFIO_L34P/_DQ51L/CQ1L_D	P4
K7	IO_B1_K7/_DIFFIO_L21N	IO_B2_P6/_DIFFIO_L52P	P6
K8	IO_B1_K8/_DIFFIO_L20N	IO_B2_P7/_DIFFIO_L48N	P7
L8	IO_B1_L8/_DIFFIO_L20P	IO_B2_R1/_DIFFIO_L33N/_DO1L	R1
		IO_B2_R2/_DIFFIO_L33P/_DO1L	R2
		IO_B2_R7/_DIFFIO_L53P	R7
		IO_B2_T4/_DQ53L/CQ3L#_CDPCLK1	T4
		IO_B2_T5/_DM3L/BWS#3L	T5
		IO_B2_T7/_DIFFIO_L53N	T7
		IO_B2_U1/_DIFFIO_L36N/_DQ3L	U1
		IO_B2_U2/_DIFFIO_L35P/_DM1R/BWS#1L	U2
		IO_B2_V1/_DIFFIO_L38N/_DQ3L	V1
		IO_B2_V2/_DIFFIO_L38P/_DQ3L	V2
		IO_B2_W1/_DIFFIO_L44N/_DQ3L	W1
		IO_B2_W2/_DIFFIO_L44P/_DQ3L	W2
		IO_B2_Y1/_DIFFIO_L45N/_DQ3L	Y1
		IO_B2_Y2/_DIFFIO_L45P/_DQ3L	Y2

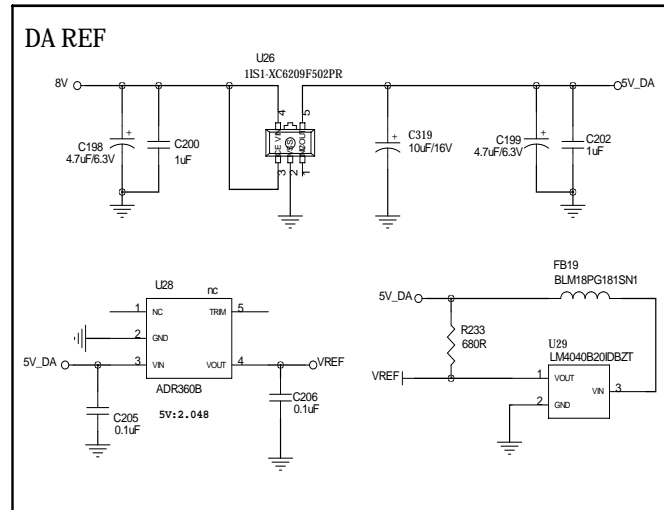
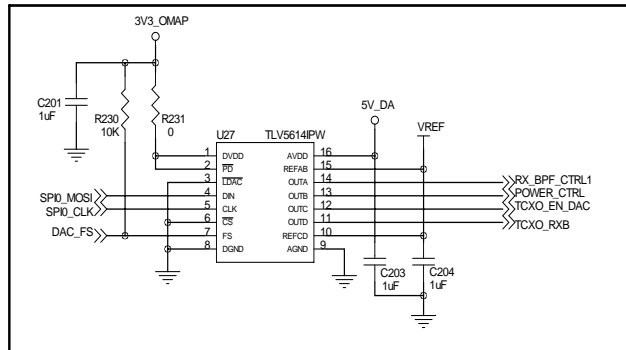
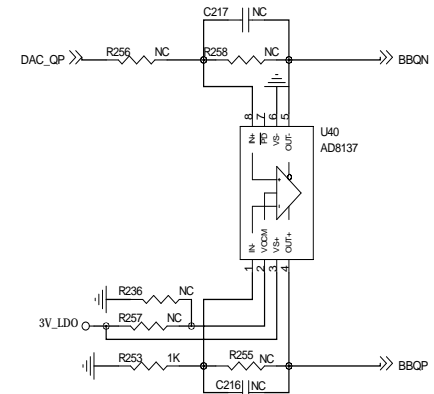
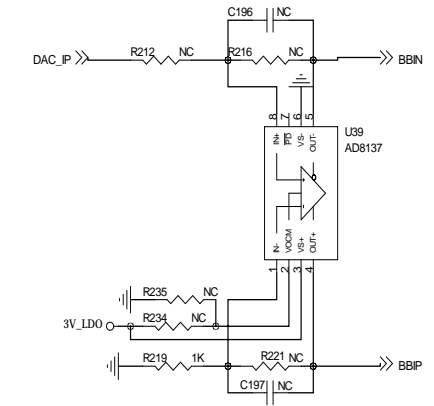
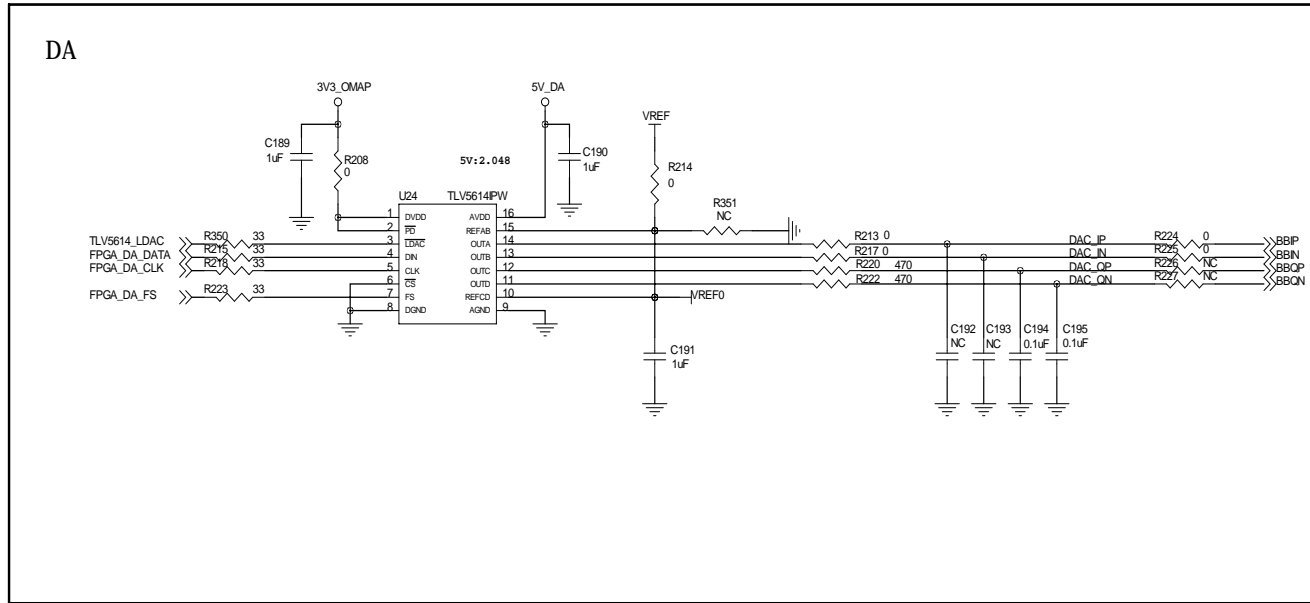
EP4CE30F484  
 VERSION : 1.0  
 PAGE : 2 of 8  
 DATE : APRIL 2010

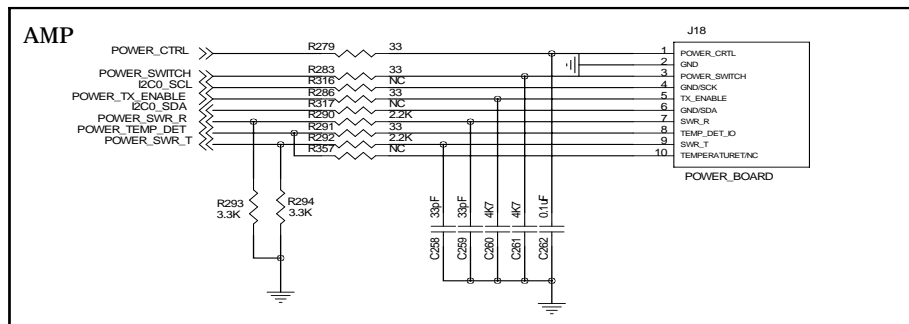
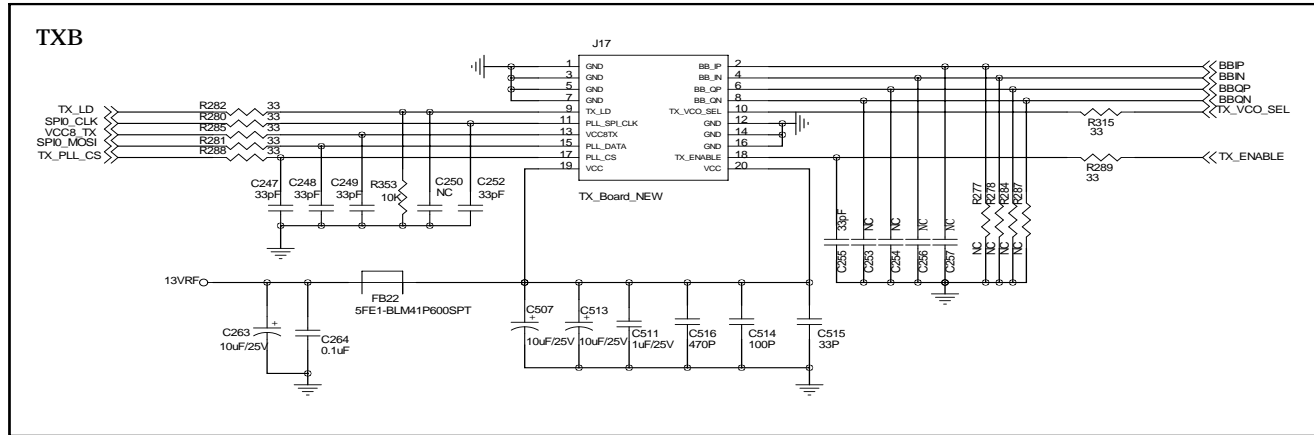
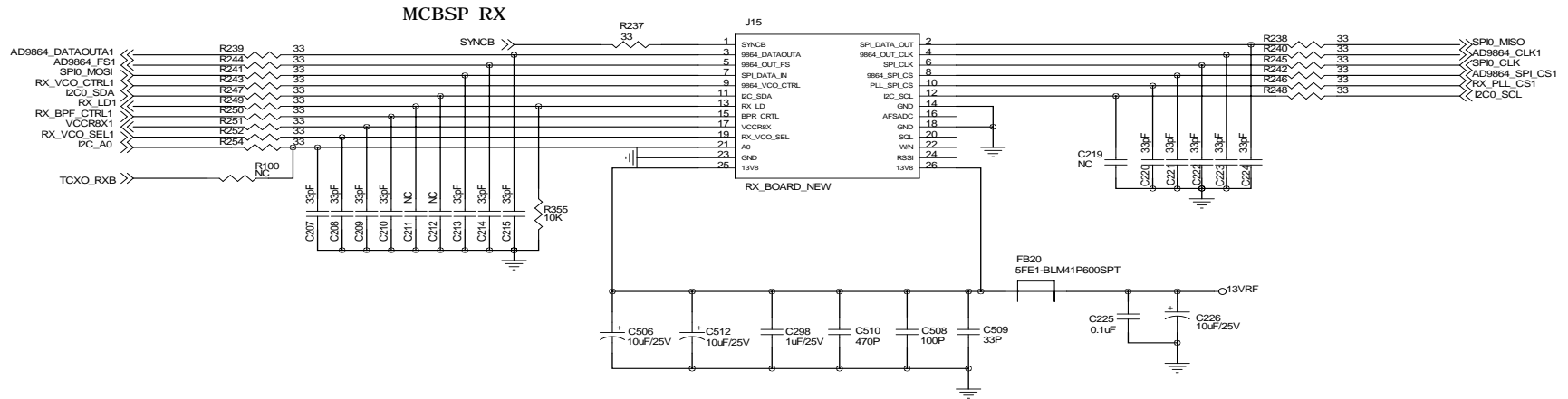


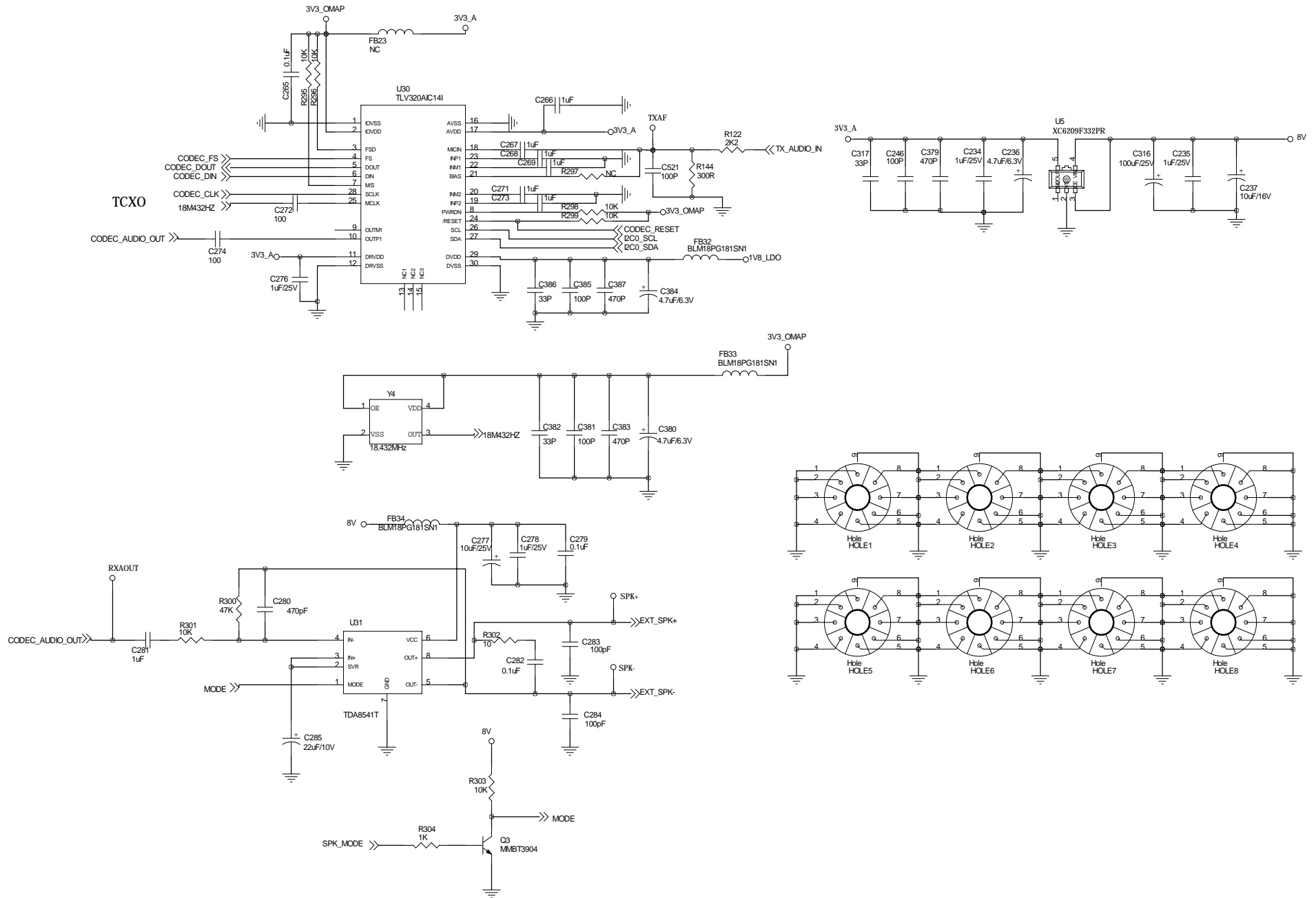


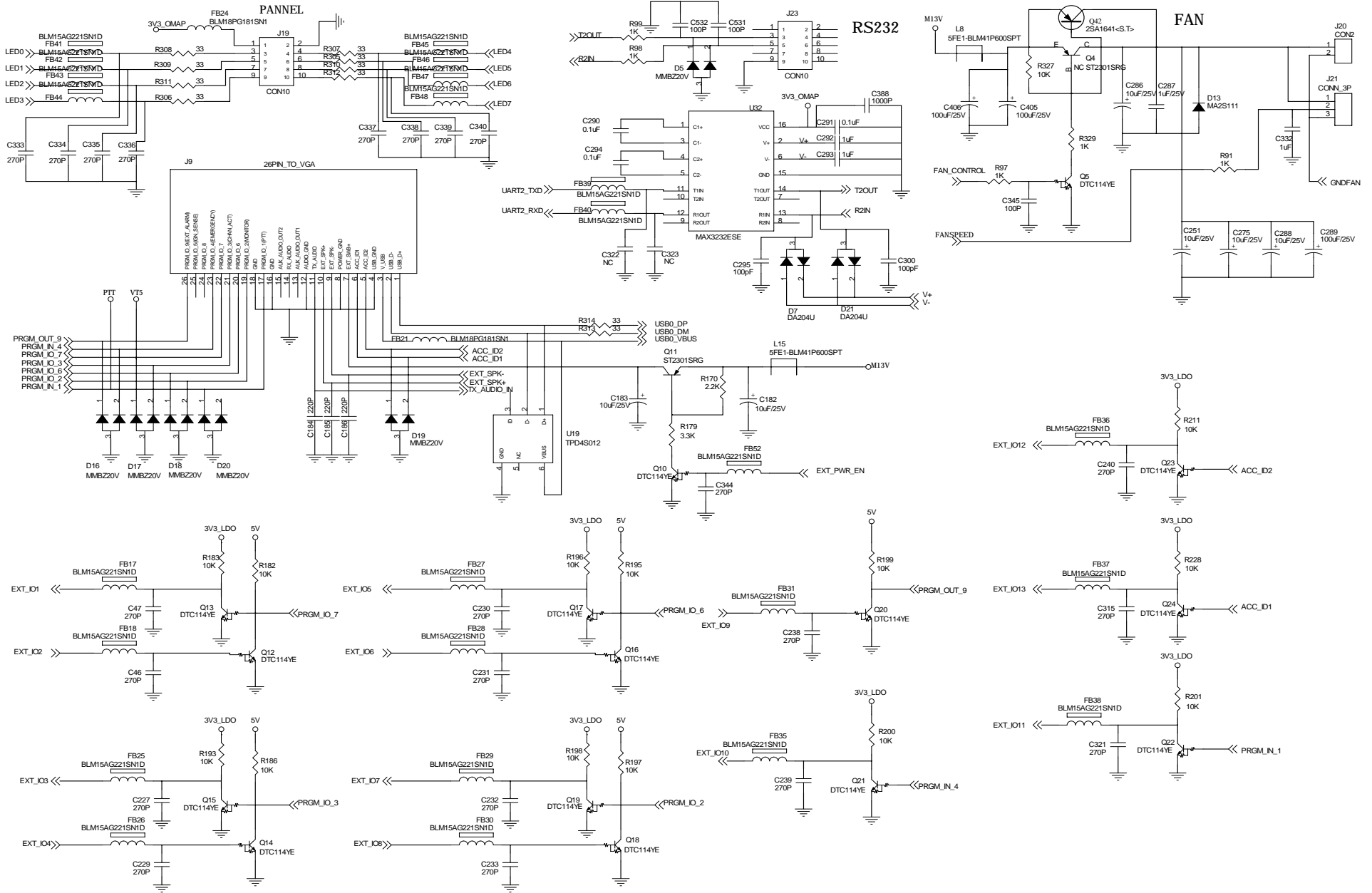




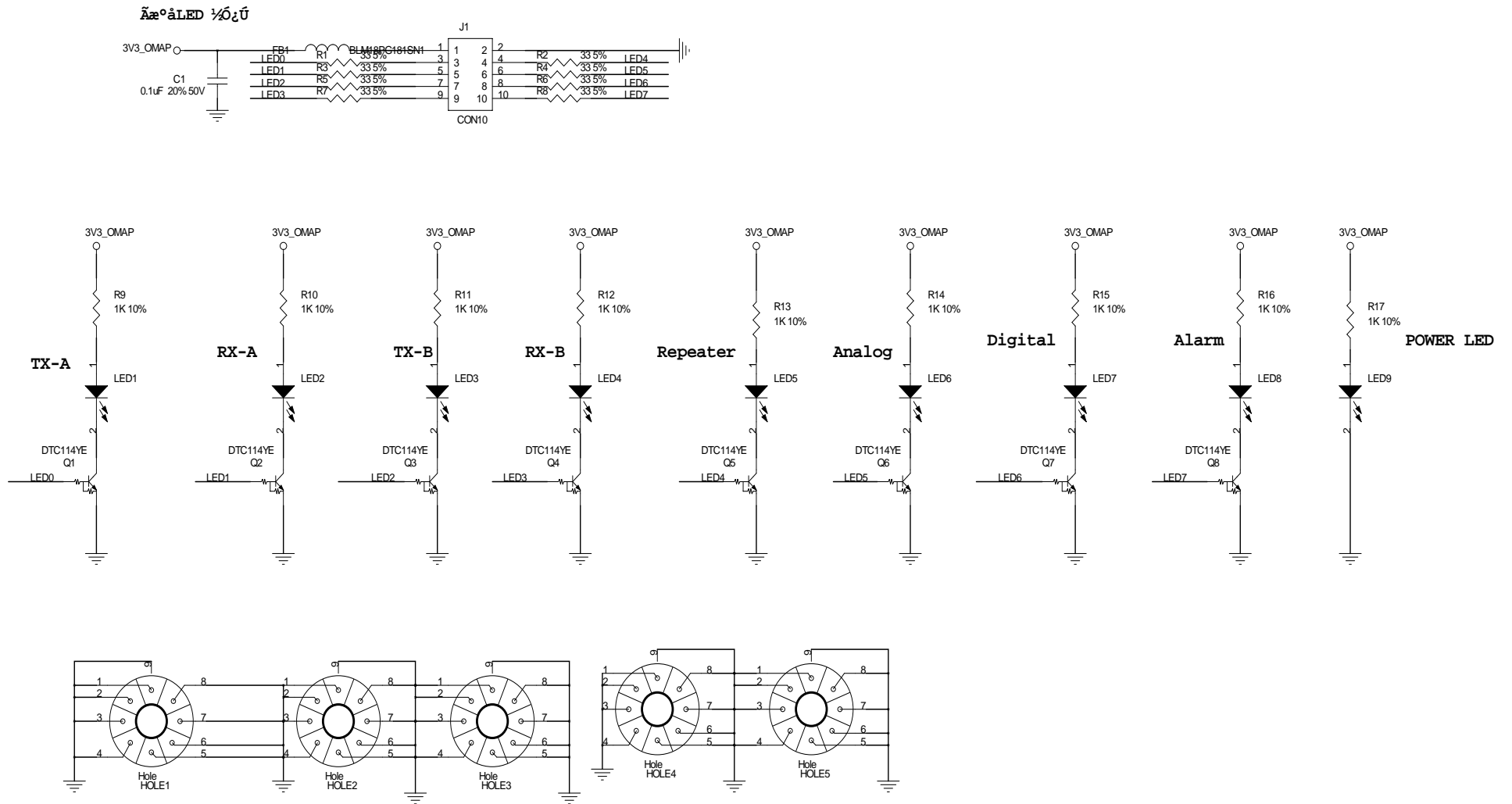




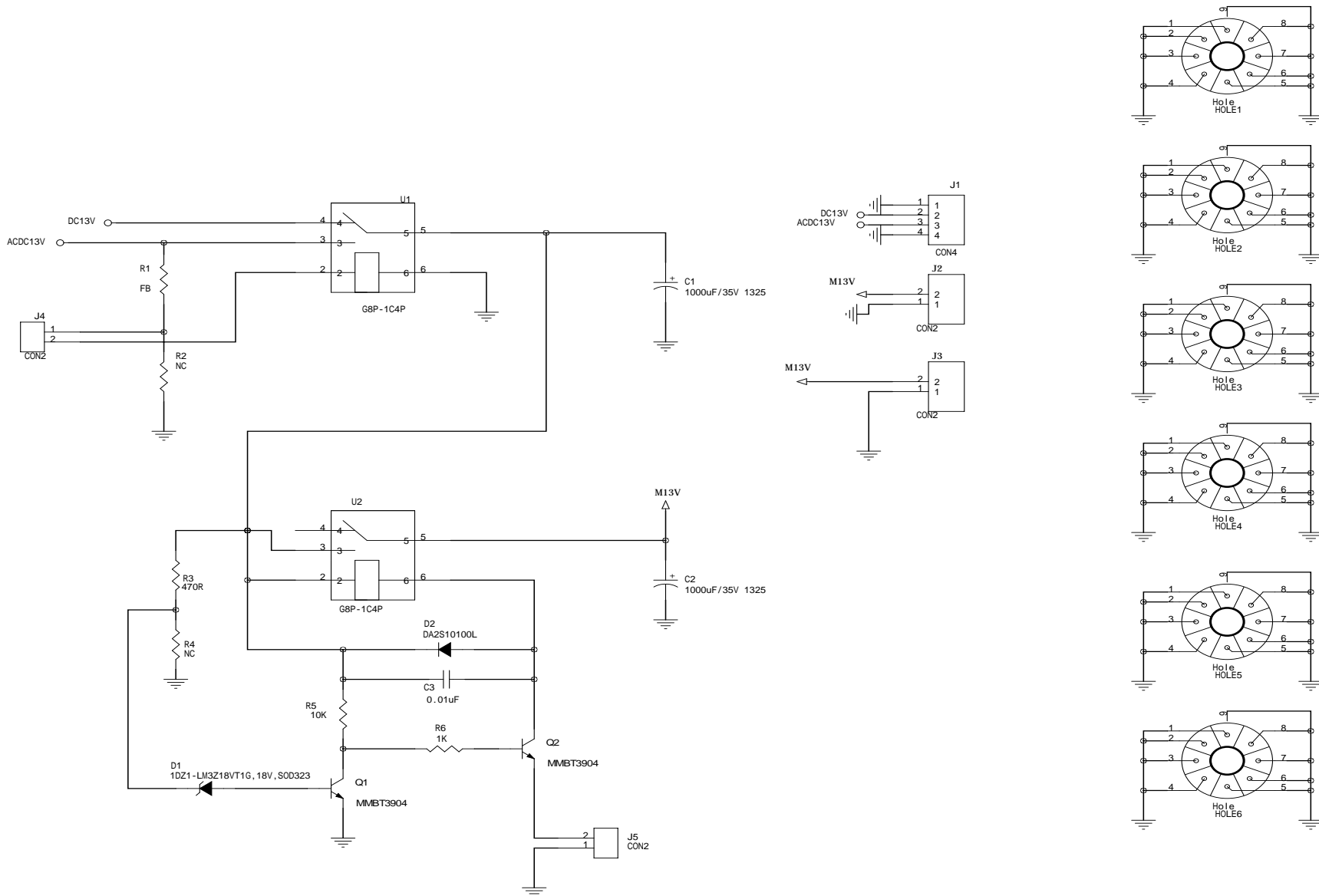




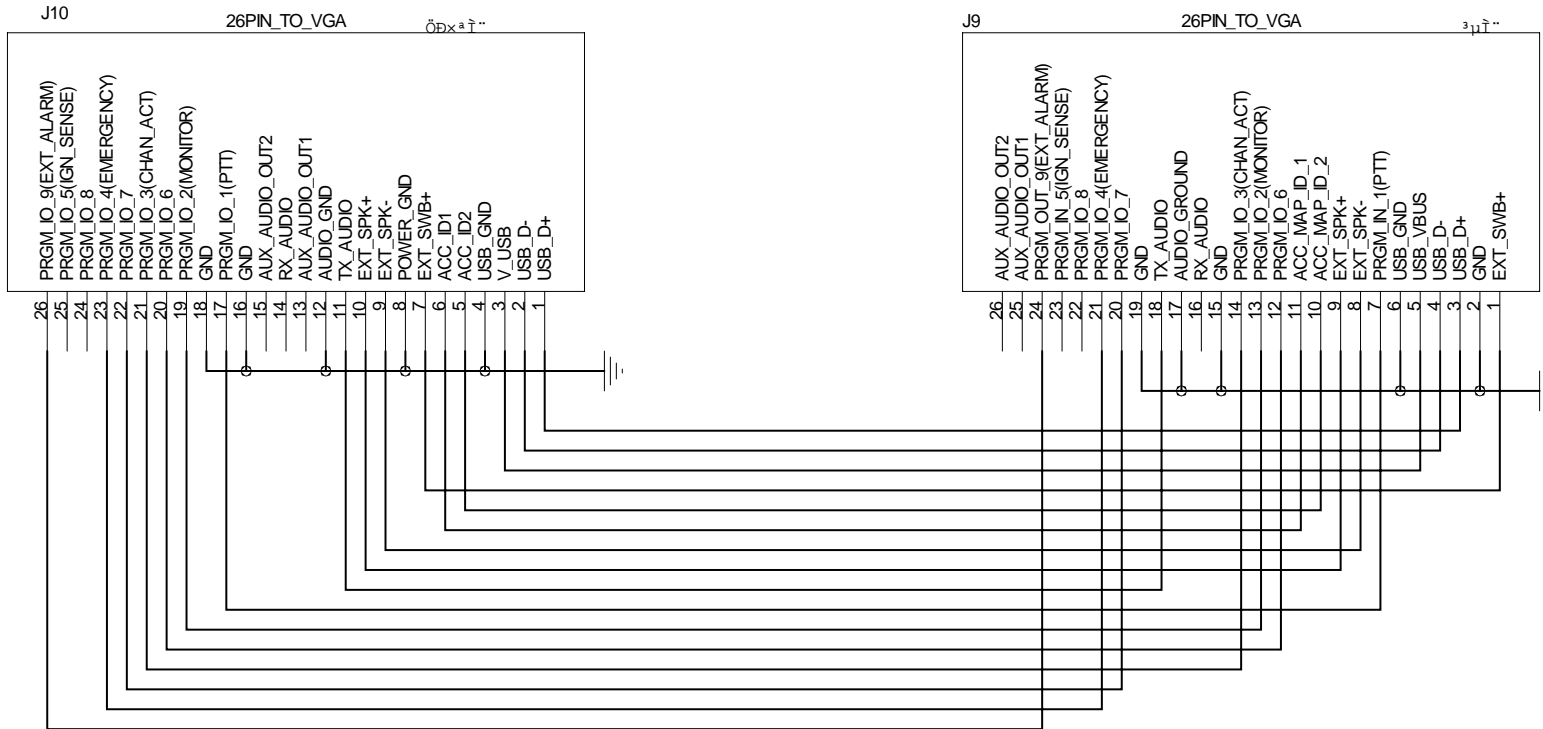
# Figure 17 Front Panel Schematic Diagram



# Figure 18 Power Board Schematic Diagram



# Figure 19 Accessory Schematic Diagram



# Appendix2 136-174 MHz VHF Band Spare Part List

## Table 1 Part List(RX Module Section)

Part No.	Part Name	Specification	Quantity	Position
1DR1-MM3Z15V T1G	SMD anti-static zener diode	MM3Z2V4T1 series, 15V, W=1.2mm, L=2.5mm, H=1.0mm, pb-free	1	D5000
1DS1-DA2S1010 0L	R SMD switch diode	DA2S10100L	2	D1000, D1001
1DS1-HSC277	R SMD switch diode (off production)	HSC277, 1608	4	D3025, D3026, D3027, D3028
1DS1-RB706F-4 0	R SMD switch diode	Schottky diode RB706F-40, SOT-323	2	D3029, D3000
1DV1-1SV305	R SMD varactor diode	1SV305	8	D1002, D1003, D1004, D1005, D1006, D1007, D1008, D1009
1DV1-HVC376B	R SMD varactor diode (off production)	HVC376B(B9)	26	D3001, D3002, D3003, D3004, D3005, D3006, D3007, D3008, D3009, D3010, D3011, D3012, D3013, D3014, D3015, D3016, D3017, D3018, D3019, D3020, D3021, D3022, D3023, D3024, D4000, D4001
1IS1-GT3136	E SMD specialized IC	GT3136, SSOP16	1	IC3004
1IS1-LM2941S	SMD specialized IC	LM2941S/TO-236, 5PIN, low dropout voltage regulator, pb-free	1	U5000
1IS1-PGA103	Broad band low noise amplifier	PGA-103+, 0.05to4GHz, SOT-89, PACKAGE, Mini-Circuits brand, RoHS	3	IC6003, IC6004, IC6006
1IS1-SKY72310	PLL chip	SKY72310, 24 pin QFN 4mmX4mm pb-free(QFN-N24_B4x4- P0_5), pb-free	1	IC1000
1IS1-TC75S51F	SMD single	TC75S51F,	2	IC6001, IC6002



	operational amplifier IC	SSOP5-P-0.95		
1IS1-XC6209F30 2PR	SMD voltage regulator IC	XC6209F302PR, SOT-89-5, 3.0V	2	Q1000, Q4002
1IS1-XC6209F33 2PR	SMD voltage regulator IC	XC6209F332PR, SOT-89-5, 3.3V	3	Q4004, Q1003, Q1006
1IS1-XC6209F50 2PR	SMD voltage regulator IC	XC6209F502PR, SOT-89-5, 5.0V	6	Q4003, Q1002, Q1004, Q3000, Q3003, Q3005
1TC1-UMC4	R SMD multiunit tube	UMC4, NPN/PNP multiunit tube	2	U1000, U3000
1TF1-2SJ243	R SMD FET(off production)	2SJ243-SMD	2	Q1008, Q1010
1TT1-2SC3356-R24	R SMD triode (off production)	2SC3356-R24, SOT23, NPN	7	Q1009, Q1011, Q2002, Q3001, Q3002, Q3004, Q4000
1TT1-2SC4617-R	R SMD triode	2SC4617-R(BR), EMT3	2	Q1001, Q1005
1TT1-2SC5006	SMD triode(off production)	2SC5006	1	Q1007
1TT1-DTC114YE	SMD triode	Digital triode DTC114YE-SMD	2	Q4001, Q5000
2CC1-16-C0G50 0-100D	R flake multi-layer capacitor	1608, 10P±0.5P, 50V, C0G	6	C1085, C1086, C3013, C3015, C3023, C3025
2CC1-16-C0G50 0-9R0C	R flake multi-layer capacitor	1608, 9P±0.25P, 50V, C0G	2	C1108, C1068
2CC1-16-C0G50 0-270J	R flake multi-layer capacitor	1608, 27P±5%, 50V, C0G	2	C1079, C4019
2CC1-16-C0G50 0-430J	R flake multi-layer capacitor	1608, 43P±5%, 50V, C0G	2	C1102, C1118
2CC1-16-C0G50 0-4R0B	flake multi-layer capacitor	1608, 4P±0.1P, 50V, C0G	3	C1109, C3001, C2019
2CC1-16-C0G50 0-101J	R flake multi-layer capacitor	1608, 100P±5%, 50V, C0G	58	C1001, C1004, C1010, C1015, C1018, C1021, C1024, C1026, C1029, C1035, C1037, C1039, C1042, C1044, C1046, C1049, C1051, C1053, C1059, C1063, C1064, C1104, C1105, C1112,

				C1119, C2008, C2010, C2012, C2017, C3027, C3031, C3040, C3042, C3047, C3082, C3091, C3095, C3110, C1034, C1056
2CC1-16-C0G50 0-120J	R flake multi-layer capacitor	1608, 12P±5%, 50V, C0G	3	C3106, C2030, C2032
2CC1-16-C0G50 0-121J	R flake multi-layer capacitor	1608, 120P±5%, 50V, C0G	2	C2021, C2023
2CC1-16-C0G50 0-150J	R flake multi-layer capacitor	1608, 15P±5%, 50V, C0G	7	C3064, C3072, C3107, C3005, C3006, C3010, C3011
2CC1-16-C0G50 0-180J	R flake multi-layer capacitor	1608, 18P±5%, 50V, C0G	2	C1094, C3104
2CC1-16-C0G50 0-1R0B	flake multi-layer capacitor	1608, 1P±0.1P, 50V, C0G	8	C1103, C1117, C6020, C6026, C6036, C6041, C6057, C6063
2CC1-16-C0G50 0-200J	R flake multi-layer capacitor	1608, 20P±5%, 50V, C0G	2	C1114, C1115
2CC1-16-C0G50 0-220J	R flake multi-layer capacitor	1608, 22P±5%, 50V, C0G	4	C3050, C3021, C3022, C2031
2CC1-16-C0G50 0-221J	R flake multi-layer capacitor	1608, 220P±5%, 50V, C0G	4	C3052, C3057, C3084, C3088
2CC1-16-C0G50 0-240J	R flake multi-layer capacitor	1608, 24P±5%, 50V, C0G	3	C1100, C1054, C1055
2CC1-16-C0G50 0-300J	R flake multi-layer capacitor	1608, 30P±5%, 50V, C0G	2	C1095, C1096
2CC1-16-C0G50 0-330J	flake multi-layer capacitor	1608, 33P±5%, 50V, C0G	2	C3019, C3020
2CC1-16-C0G50 0-470J	R flake multi-layer capacitor	1608, 47P±5%, 50V, C0G	45	C1084, C1099, C2024, C6021, C6022, C6023, C6024, C6025, C6027, C6028, C6029, C6030, C6031, C6032, C6033, C6034, C6035, C6037, C6038, C6039, C6040,

				C6042, C6043, C6044, C6045, C6046, C6047, C6048, C6049, C6050, C6051, C6052, C6053, C6054, C6055, C6056, C6058, C6059
2CC1-16-C0G50 0-471J	R flake multi-layer capacitor	1608, 470P±5%, 50V, C0G	16	C3070, C1006, C1007, C1008, C1067, C1089, C1090, R3037, C3003, C3004, C3007, C3009, C3012, C1012, C1032, C1033
2CC1-16-C0G50 0-560J	R flake multi-layer capacitor	1608, 56P±5%, 50V, C0G	3	C3059, C4016, C4006
2CC1-16-C0G50 0-5R0B	flake multi-layer capacitor	1608, 5P±0.1P, 50V, C0G	7	C1060, C1061, C1062, C1077, C1110, C1111, C3000
2CC1-16-C0G50 0-620J	flake multi-layer capacitor	1608, 62P±5%, 50V, C0G	2	C2022, C2025
2CC1-16-C0G50 0-680J	R flake multi-layer capacitor	1608, 68P±5%, 50V, C0G	3	C1091, C3056, C4053
2CC1-16-C0G50 0-6R0C	R flake multi-layer capacitor	1608, 6P±0.25P, 50V, C0G	3	C1076, C1073, C2018
2CC1-16-C0G50 0-820J	R flake multi-layer capacitor	1608, 82P±5%, 50V, C0G	2	C2020, C2026
2CC1-16-X7R50 0-102K	R flake multi-layer capacitor	1608, 1000P±10%, 50V, X7R	22	C3051, C1072, C1092, C1093, C1097, C3033, C3034, C3035, C3036, C3037, C3038, C3044, C3073, C3075, C3093, C3099, C3102, C6001, C6003, C6010, C6012, C3076
2CC1-16-X7R50 0-103K	R flake multi-layer capacitor	1608, 10nF±10%, 50V, X7R	57	C1002, C1003, C1016, C1017, C1022, C1023, C1027, C1028, C1036, C1038, C1040, C1043, C1045, C1047, C1050, C1052, C1080, C1082, C3028, C3032, C3043, C3048, C3053, C3078,

				C3096, C3098, C3111, C5000, C5001, C5002, C5004, C5006, C5007, C5008, C6004, C6013, C1041, C1048, C4008, C4000, C4001
2CC1-16-X7R50 0-152K	flake multi-layer capacitor	1608, 1500P±10%, 50V, X7R	1	C3085
2CC1-16-X7R50 0-182K	R flake multi-layer capacitor	1608, 1800P±10%, 50V, X7R	1	C3077
2CC1-16-X7R50 0-271K	R flake multi-layer capacitor	1608, 270P±10%, 50V, X7R	2	C1087, C1088
2CC1-16-X7R50 0-331K	flake multi-layer capacitor	1608, 330P±10%, 50V, X7R	5	C3114, C3054, C3068, C3108, C3115
2CC1-16-Y5V16 0-104Z	flake multi-layer capacitor	1608, 100nF+80%/-20%, 16V, Y5V	24	C1065, C1078, C1081, C1083, C1106, C1113, C2009, C2011, C2013, C2014, C2038, C3041, C3045, C3049, C3071, C3079, C3081, C3086, C3087, C3089, C3090, C3092, C3101, C3103
2CC1-16-Y5V25 0-105Z	flake multi-layer capacitor	1608, 1µF+80%/-20%, 25V, Y5V	3	R6004, C6014, C6015
2CE1-VS250-10 1M0607D	SMD aluminum electrolytic capacitor	SMD-6.3x7.7mm, 100uF/25V	1	C5003
2CT1-TS32-100- 220M	SMD tantalum capacitor	3216, 22µF±20%, 10V, TS series(A level)	1	C5005
2CT1-TS32-100- 2R2M	R SMD tantalum capacitor	3216, 2.2µF±20%, 10V, TS series(A level)	1	C1075
2CT1-TS32-160- 100M	R SMD tantalum capacitor	3216, 10µF±20%, 16V, TS series(A level)	29	C4029, C4024, C4040, C4045, C4047, C4052, C6007, C1000, C1005, C1014, C1019, C1020, C1025, C1030, C1031, C6002, C6008, C6011, C3029, C3030, C3046, C3067, C3094, C3097,

				C3109, C3112, C3113, C1057, C1058
2CT1-TS32-350-R10M	R SMD tantalum capacitor	3216, 0.1 $\mu$ F $\pm$ 20%, 35V, TS series(A level)	2	C1069, C3100
2CT1-TS32-350-R33M	R SMD tantalum capacitor	3216, 0.33 $\mu$ F $\pm$ 20%, 35V, TS series(A level)	1	C1070
2CT1-TS32-6R3-150M	R SMD tantalum capacitor	3216, 15 $\mu$ F $\pm$ 20%, 6.3V, TS series(A level)	3	C1009, C1011, C1013
2LL1-16-1R0K	R laminated inductor	1608, 1 $\mu$ H $\pm$ 10%(MLF1608A1R0K)	2	L1025, L3013
2LL1-16-3R3K	R laminated inductor	1608, 3.3 $\mu$ H $\pm$ 10%(MLF1608A3R3K TA00)	3	L4004, L1007, L1029
2LW1-16UC-181J	SMD wire winding inductor	1608, 180nH $\pm$ 5%, ceramic core(C1608CB-R18J)	1	L2006
2LW1-16UC-330J	R SMD wire winding inductor	1608, 33nH $\pm$ 5%, ceramic core (C1608CB-33NJ)	1	L1013
2LW1-20UC-470J	R SMD wire winding inductor	2012, 47nH $\pm$ 5%, ceramic core (C2012C-47NJ)	4	L3004, L3000, L3001, L3002
2LW1-16UC-271G	SMD wire winding inductor	1608, 270nH $\pm$ 2%, ceramic core (C1608CB-R27G-RF)	2	L3016, L3021
2LW1-16UC-R33G	SMD wire winding inductor	1608, 330nH $\pm$ 2%(C1608BR33G), pb-free	10	L1005, L1006, L1011, L1015, L1023, L1024, L1026, L1027, L1028, L1030
2LW1-20UC-102J	SMD wire winding inductor	2012, 1 $\mu$ H $\pm$ 5%, ceramic core (C2012C-1R0J)	3	L2004, L3007, L3024
2LW1-20UC-330J	R SMD wire winding inductor	2012, 33nH $\pm$ 5%, ceramic core (C2012C-33NJ)	2	L2009, L2010
2LW1-20UC-330GC	SMD wire winding inductor	2012, 33nH $\pm$ 2%, 500mA, LQW2BAS33NG00, SMD wire winding inductor, muRata brand	1	L1016
2LW1-20UC-390GB	SMD wire winding inductor	2012, 39nH $\pm$ 2%, 500mA, LQW2BAS39NG00, SMD wire winding	1	L1017

		inductor, muRata brand		
2LW1-20UC-331 J	SMD wire winding inductor	2012, 330nH±5%, ceramic core (high frequency)	3	L1019, L1020, L4001
2LW1-25UC-103 J	R SMD wire winding inductor	2520, 10µH±5%, ceramic core (FLM2520-100J)	4	L1022, L3005, L4002, L4003
2RE1-16-1000	SMD precision resistor	1608, 100Ω±1%	8	R1008, R1009, R1010, R1013, R1014, R1016, R1022, R1024
2RE1-16-1200	SMD precision resistor	1608, 120Ω±1%	7	R1005, R1021, R1025, C4009, C4010, R3002, R3003
2RE1-16-3301	SMD precision resistor	1608, 3.3K±1%	2	R3029, C3083
2RE1-16-47R0	SMD precision resistor	1608, 47Ω±1%	2	R1019, R3000
2RS1-16-0000	R flake resistor	1608, 0Ω	19	R1017, R1018, R1029, R2010, L2012, C3039, L3015, R3018, R3027, R3028, R3031, R3038, R3042, R6012, R6013, R1020, R6040, R6041, R4003
2RS1-16-102J	R flake resistor	1608, 1K±5%	6	R1023, R1028, R1042, R3036, R4004, R4009
2RS1-16-103J	R flake resistor	1608, 10K±5%	19	R1035, R1036, R1037, R1007, R1011, R1030, R1031, R1032, R1033, R1034, R1039, R1040, R3017, R6007, R6009, R1041, R4002, R4007, R4008
2RS1-16-104J	R flake resistor	1608, 100K±5%	13	R3005, R3006, R3007, R3008, R3009, R3010, R3011, R3012, R3013, R3014, R3015, R3016, R4006
2RS1-16-124J	R flake resistor	1608, 120K±5%	1	R1026
2RS1-16-153J	R flake resistor	1608, 15K±5%	1	R6005
2RS1-16-182J	R flake resistor	1608, 1.8K±5%	2	R3024, R3026

2RS1-16-184J	R flake resistor	1608, 180K±5%	1	R3041
2RS1-16-220J	R flake resistor	1608, 22Ω±5%	1	R2018
2RS1-16-221J	R flake resistor	1608, 220Ω±5%	2	R2011, R2012
2RS1-16-223J	R flake resistor	1608, 22K±5%	4	R3039, R3040, R3045, R3046
2RS1-16-270J	R flake resistor	1608, 27Ω±5%	1	R2009
2RS1-16-273J	R flake resistor	1608, 27K±5%	2	R6008, R6010
2RS1-16-362J	R flake resistor	1608, 3.6K±5%	1	R6011
2RS1-16-363J	R flake resistor	1608, 36K±5%	2	R3030, R3032
2RS1-16-364J	flake resistor	1608, 360K±5%	1	R3049
2RS1-16-392J	R flake resistor	1608, 3.9K±5%	3	R1002, R1015, R3043
2RS1-16-472J	R flake resistor	1608, 4.7K±5%	8	R1006, R3033, R1000, R1001, R3019, R3021, R3044, R3047
2RS1-16-473J	R flake resistor	1608, 47K±5%	8	R3023, R3025, R5000, R5001, R6042, R6043, R6052, R6053
2RS1-16-513J	R flake resistor	1608, 51K±5%	1	R6001
2RS1-16-560J	R flake resistor	1608, 56Ω±5%	2	R3052, L4000
2RS1-16-562J	R flake resistor	1608, 5.6K±5%	2	R3050, R6000
2RS1-16-680J	R flake resistor	1608, 68Ω±5%	2	R1004, R1044
2RS1-16-511J	flake resistor	1608, 510Ω±5%	1	R4000
2RS1-16-682J	R flake resistor	1608, 6.8K±5%	2	R1003, R1043
2RS1-16-821J	R flake resistor	1608, 820Ω±5%	1	R3022
2RS1-16-822J	R flake resistor	1608, 8.2K±5%	2	R2007, R5003
2RS1-32-000O	R flake resistor	3216, 0Ω±5%	1	U5002
2RS1-20-000O	R flake resistor	2012, 0Ω	9	L2011, L2013, L3003, L3006, L3008, L3009, L3010, L3011, L3012

3FW1-42932-30 2320	R SMD fuse	429003/433003/466003, 3216, 3A/32V	1	CB5000
5FC1-DSF51R6 M-0705	R SMD crystal filter, PT568/78/72/ 62/65/68/DR5 5/DM58/3208/ V68/E66	DSF753SBF, 51.65MHz±4KHz/3dB, 7.0*5.0*1.3, DP77/CD37/RD47/AP57	2	Z3000, Z3001
5FE1-BLM11A60 1S	R SMD EMI suppression filter	1608, BLM11A601S/BLM18AG 601S(0138-05)	45	L1000, L1001, L1003, L1004, L1008, L1009, L1010, L1012, L1014, L1018, L1021, L2001, L2002, L3019, L6000, L6001, R6014, R6015, R6016, R6017, R6019, R6020, R6022, R6023, R6024, R6026, R6027, R6028, R6029, R6030, R6032, R6035, R6036, R6037, R6039, R6044, FB4000
5FE1-BLM21P30 0S	R SMD EMI suppression filter	2012, BLM21P300S/BLM21PG 300S(0149-05)	1	L5000
2RT1-NTH5G16 P39B153K	SMD thermal resistor	NTH5G16P39B153K, 15K, 0603	1	R3051
6PM7-4067-HRB	DR650-02 RX board	DR650-02-RX-130304.P CB, 4 layers, thickness 1.6MM, 194X90mm, FR-4, for all frequency range	1	
2LL1-16-R56JT	Laminated inductor	1608, 560nH±5%, (MLG1608SR56JT-561J)	1	L3023
1IS1-SYM25DH W	SMD frequency mixer	SYM-25DHW+, 80to2500MHz, TTT167package, Mini-Circuits brand, RoHS	1	IC3005
2CC1-16-C0G50 0-160J	R flake multi-layer capacitor	1608, 16P±5%, 50V, C0G	2	C3080, C4007
2CC1-16-C0G50 0-2R0B	flake multi-layer capacitor	1608, 2P±0.1P, 50V, C0G	3	C4062, C3060, C3002
2LL1-16-R56K	R laminated inductor	1608, 560nH±10%(MLF1608D	1	L3022



		R56K)		
2CC1-16-C0G50 0-151J	R flake multi-layer capacitor	1608, 150P±5%, 50V, C0G	1	C3058
2LL1-16-R22K	R laminated inductor	1608, 0.22μH±10%(MLF1608D R22K TA00)	1	L3017
2RS1-16-271J	R flake resistor	1608, 270Ω±5%	1	L3018
2CC1-16-C0G50 0-3R0B	flake multi-layer capacitor	1608, 3P±0.1P, 50V, C0G	2	C1101, C1116
1IS1-AD9864	IF digital system	AD9864, LFCSP-N48_B7X6_75_ P0_5, pb-free	1	U4000
1IM1-AT24C08C N-SH	E R SMD memorizer IC for analog commercial portable and radio	EEPROM, AT24C08CN-SH(8-SOIC )	1	IC6005
2CC1-16-Y5V50 0-104Z	flake multi-layer capacitor	1608, 0.1μF+80%/-20%, 50V, Y5V, replacement part:2CC1-16-Y5V250-1 04Z	7	C4004, C4018, C4023, C4030, C4031, C4046, C4055
2RS1-16-561J	R flake resistor	1608, 560Ω±5%	1	R4005
2RS1-16-203J	R flake resistor	1608, 20K±5%	1	R4001
2CC1-16-C0G50 0-181J	flake multi-layer capacitor	1608, 180P±5%, 50V, C0G	1	C4020
2LW1-25UC-332 K	SMD wire winding inductor	2520, 3.3μH±10%, ceramic core (NL252018T-3R3K/NLV2 5T-3R3K)	1	L4005
2CC1-16-C0G50 0-130J	R flake multi-layer capacitor	1608, 13P±5%, 50V, C0G	1	C3018
2CC1-16-C0G50 0-110J	R flake multi-layer capacitor	1608, 11P±5%, 50V, C0G	1	C3026
2LH1-0908-140G	SMD air core inductor	0908SQ-14NJLC, 14nH±2%, 0908SQ package, COILCRAFT	6	L3025, L3026, L3027, L3028, L3029, L3030
2CC1-16-C0G50	flake	1608, 680P±5%, 50V,	1	C3008

0-681J	multi-layer capacitor	C0G		
2CC1-16-X7R16 0-104K	flake multi-layer capacitor	1608, 100nF±10%, 16V, X7R	2	C4015, C4058
0SS2-4095-HRA	STR-V RX board plug-in unit	STR-V RX board plug-in unit, pb-free	1	D1000
3CB3-A2548WV-2X13P	Plug-in board-to-board connector	2*13 socket(male), 180 degrees, interval2.54mm, 40.64X9X9.1mm	1	J6000
3CR7-SMA-50KWE-2	RF coaxial connector	SMA-50KWE-2, 5PIN plug-in unit, 90 degrees, length 23mm.pitch:2.54mm	2	J3000, J3002
6SS2-4095-HTA	STR-V TX board suite (131031)	Sepura VHF repeater, STR-V TX board suite, pb-free	1	
6SS1-4095-HTA	STR-V TX board SMD material(131031)	Sepura VHF repeater, STR-V TX board SMD material, pb-free	1	D105, D110
3FW1-42932-302320	R SMD fuse	429003/433003/466003, 3216, 3A/32V	1	CB400
1DR1-MM3Z12VT1G	Anti-static zener diode	MM3Z12VT1G, 3V, SOD323, pb-free	1	D400
1DS1-HSC277	R SMD switch diode(off production)	HSC277, 1608	1	D100
1DV1-1SV278	R SMD varactor diode	1SV278(T1)	2	D105, D110
1DV1-1SV305	R SMD varactor diode	1SV305	8	D101, D102, D103, D104, D106, D107, D108, D109
1IS1-LM2941S	SMD specialized IC	LM2941S/TO-236, 5PIN, low dropout voltage regulator,pb-free	1	U400
1IS1-SKY72310	PLL chip	SKY72310, 24 pin QFN 4mmX4mm pb-free(QFN-N24_B4x4-P0_5), pb-free	1	IC100
1IS1-PGA103	Broad band low noise amplifier	PGA-103+, 0.05to4GHz, SOT-89, PACKAGE, Mini-Circuits brand, RoHS	1	IC306

1IS1-TC75S51F	SMD single operational amplifier IC	TC75S51F, SSOP5-P-0.95	2	IC300, IC301
1IS1-XC6209F302PR	SMD voltage regulator IC	XC6209F302PR, SOT-89-5, 3.0V	1	IC101
1IS1-XC6209F332PR	SMD voltage regulator IC	XC6209F332PR, SOT-89-5, 3.3V	1	IC103
1IS1-XC6209F502PR	SMD voltage regulator IC	XC6209F502PR, SOT-89-5, 5.0V	4	IC102, IC104, IC105, IC302
1TC1-UMC4	R SMD multiunit tube	UMC4, NPN/PNP multiunit tube	1	U100
1TF1-2SJ243	R SMD FET(off production)	2SJ243-SMD	1	Q104
1TT1-2SC3356-R24	R SMD triode (off production)	2SC3356-R24, SOT23, NPN	3	Q105, Q106, Q202
1TT1-2SC4617-R	R SMD triode	2SC4617-R(BR), EMT3	1	Q101
1TT1-DTC114YE	SMD triode	Digitak triode DTC114YE-SMD	2	Q204, Q400
1TT1-FMMT717TA	R SMD triode	FMMT717A, PNP, SOT23	1	Q203
2CC1-16-C0G500-100D	R flake multi-layer capacitor	1608, 10P±0.5P, 50V, C0G	3	C188, C189, C171
2CC1-16-C0G500-101J	R flake multi-layer capacitor	1608, 100P±5%, 50V, C0G	65	C161, C166, C167, C182, C184, C186, C199, C208, C212, C214, C216, C224, C228, C234, C239, C242, C246, C255, C289, C291, C295, C297, C300, C301, C302, C303, C304, C305, C306, C307, C308, C309, C310, C311, C312, C315, C316, C317, C320, C321, C322, C323, C340, C341, C344, C345
2CC1-16-C0G500-102J	Flake multi-layer capacitor	1608, 1000P±5%, 50V, C0G	8	C175, C240, C325, C329, C332, C334, C342, R333
2CC1-16-C0G50	R flake	1608, 22P±5%, 50V,	1	C230

0-220J	multi-layer capacitor	C0G		
2CC1-16-C0G50 0-3R0B	flake multi-layer capacitor	1608, 3P±0.1P, 50V, C0G	2	C133, C169
2CC1-16-C0G50 0-121J	R flake multi-layer capacitor	1608, 120P±5%, 50V, C0G	1	C244
2CC1-16-C0G50 0-180J	R flake multi-layer capacitor	1608, 18P±5%, 50V, C0G	1	C130
2CC1-16-C0G50 0-1R0B	flake multi-layer capacitor	1608, 1P±0.1P, 50V, C0G	8	C129, C135, C177, C179, C313, C314, C318, C319
2CC1-16-C0G50 0-430J	R flake multi-layer capacitor	1608, 43P±5%, 50V, C0G	2	C221, C136
2CC1-16-C0G50 0-470J	R flake multi-layer capacitor	1608, 47P±5%, 50V, C0G	2	C220, C256
2CC1-16-C0G50 0-471J	R flake multi-layer capacitor	1608, 470P±5%, 50V, C0G	4	C105, C107, C108, C127
2CC1-16-C0G50 0-110J	R flake multi-layer capacitor	1608, 11P±5%, 50V, C0G	1	C180
2CC1-16-C0G50 0-680J	R flake multi-layer capacitor	1608, 68P±5%, 50V, C0G	1	C181
2CC1-16-C0G50 0-5R0B	flake multi-layer capacitor	1608, 5P±0.1P, 50V, C0G	3	C163, C164, C165
2CC1-16-C0G50 0-620J	flake multi-layer capacitor	1608, 62P±5%, 50V, C0G	4	C225, C232, C233, C257
2CC1-16-C0G50 0-6R0C	R flake multi-layer capacitor	1608, 6P±0.25P, 50V, C0G	2	C231, C235
2CC1-16-C0G50 0-150J	R flake multi-layer capacitor	1608, 15P±5%, 50V, C0G	4	C155, C156, C131, C170
2CC1-16-C0G50 0-820J	R flake multi-layer capacitor	1608, 82P±5%, 50V, C0G	2	C222, C226
2CC1-16-X7R50 0-103K	R flake multi-layer capacitor	1608, 10nF±10%, 50V, X7R	30	C101, C103, C116, C118, C122, C125,

	capacitor			C139, C141, C143, C145, C147, C149, C152, C154, C245, C253, C290, C292, C296, C298, C326, C335, C343, C400, C401, C402, C404, C406, C407, C408
2CC1-16-X7R50 0-332K	flake multi-layer capacitor	1608, 3300P±10%, 50V, X7R	1	C336
2CC1-16-X7R50 0-333K	R flake multi-layer capacitor	1608, 33nF±10%, 50V, X7R	1	C327
2CC1-16-Y5V16 0-104Z	flake multi-layer capacitor	1608, 100nF+80%/-20%, 16V, Y5V	19	C110, C112, C114, C158, C159, C162, C185, C187, C195, C196, C209, C213, C215, C217, C227, C229, C238, C241, C243
2CE1-VS250-10 1M0607D	SMD aluminum electrolytic capacitor	SMD-6.3x7.7mm, 100uF/25V	1	C403
2CT1-TS32-160- 4R7M	R SMD tantalum capacitor	3216, 4.7µF±20%, 16V, TS series (A level)	1	C178
2CT1-TS32-160- 100M	R SMD tantalum capacitor	3216, 10µF±20%, 16V, TS series (A level)	21	C100, C104, C115, C120, C121, C126, C252, C254, C282, C283, C284, C285, C286, C287, C288, C293, C294, C299, C328, C333, C405
2CT1-TS32-350- R10M	R SMD tantalum capacitor	3216, 0.1µF±20%, 35V, TS series (A level)	3	C172, C173, C174
2CC1-16-C0G50 0-240J	R flake multi-layer capacitor	1608, 24P±5%, 50V, C0G	3	C176, C183, C132
2CT1-TS32-6R3- 150M	R SMD tantalum capacitor	3216, 15µF±20%, 6.3V, TS series (A level)	1	C109
2LL1-16-3R3K	R laminated inductor	1608, 3.3µH±10%(MLF1608A3	2	L105, L117

		R3K TA00)		
2LW1-16UC-181 J	SMD wire winding inductor	1608, 180nH±5%, ceramic core (C1608CB-R18J)	1	L205
2LW1-16UC-560 G	SMD wire winding inductor	1608, 56nH±2%, ceramic core (C1608CB-56NG)	1	L113
2LW1-16UC-R33 G	SMD wire winding inductor	1608, 330nH±2%(C1608BR33 G), pb-free	6	L103, L104, L111, L115, L116, L120
2LW1-20UC-102 J	SMD wire winding inductor	2012, 1µH±5%, ceramic core (C2012C-1R0J)	2	L214, L106
2LW1-20UC-470 GB	SMD wire winding inductor	2012, 47nH±2%, 500mA, LQW2BAS47NG00, SMD wire winding inductor, muRata brand	1	L119
2LW1-20UC-560 JA	R SMD wire winding inductor	2012, 56nH±5%, ceramic core (C2012C-56NJ)	2	L209, L210
2LW1-20UC-221 J	R SMD wire winding inductor	2012, 220nH±5%, ceramic core (LQN21AR22J/LQW2BHN R22J03L)	1	L118
2LW1-20UC-330 GC	SMD wire winding inductor	2012, 33nH±2%, 500mA, LQW2BAS33NG00, SMD wire winding inductor, muRata brand	1	L107
2LW1-25UC-103 J	R SMD wire winding inductor	2520, 10µH±5%, ceramic core (FLM2520-100J)	1	L122
2RE1-16-1000	SMD precision resistor	1608, 100Ω±1%	11	R129, R124, R105, R106, R113, R115, R117, R119, R120, R121, R128
2RE1-16-1001	SMD precision resistor	1608, 1K±1%	2	R134, R135
2RE1-16-1200	SMD precision resistor	1608, 120Ω±1%	1	R108
2RE1-16-8201	R SMD precision resistor	1608, 8.2K±1%	2	R342, R403
2RS1-16-0000	R flake resistor	1608, 0Ω	21	C191, R131, R137, R335, R122, R123,

				R130, R210, L211, R325, R326, R334, R346, R348, R319, R320, R350, R313, R314, R315, R316
2RS1-16-103J	R flake resistor	1608, 10K±5%	9	R114, R132, R133, R140, R141, R142, R143, R144, R145
2RS1-16-104J	R flake resistor	1608, 100K±5%	6	R100, R103, R107, R111, R118, R127
2RS1-16-123J	R flake resistor	1608, 12K±5%	2	R343, R337
2RS1-16-124J	R flake resistor	1608, 120K±5%	2	R339, R341
2RS1-16-220J	R flake resistor	1608, 22Ω±5%	1	R218
2RS1-16-221J	R flake resistor	1608, 220Ω±5%	2	R211, R212
2RS1-16-270J	R flake resistor	1608, 27Ω±5%	2	R209, R125
2RS1-16-302J	flake resistor	1608, 3K±5%	2	R104, R116
2RS1-16-472J	R flake resistor	1608, 4.7K±5%	2	R101, R109
2RS1-16-473J	R flake resistor	1608, 47K±5%	5	R345, R110, R220, R400, R401
2RS1-16-511J	flake resistor	1608, 510Ω±5%	1	R219
2RS1-16-563J	R flake resistor	1608, 56K±5%	1	R207
2RS1-16-682J	R flake resistor	1608, 6.8K±5%	2	R102, R112
2RS1-20-000O	R flake resistor	2012, 0Ω	2	L212, L213
5FE1-BLM11A60 1S	R SMD EMI suppression filter	1608, BLM11A601S/BLM18AG 601S(0138-05)	28	L100, L101, L102, L108, L109, L110, L112, L114, L121, L123, L202, L207, L300, R301, L301, R302, R303, R304, R305, R306, R307, R308, R309, R310, R311, R312, R329, R351
5FE1-BLM21P30 0S	R SMD EMI suppression filter	2012, BLM21P300S/BLM21PG 300S(0149-05)	1	L400
5OT1-12R8-ACL 4-3225	SMD temperature compensated	KDS, 12.8MHz±1.5ppm, Vc=1.5±1V, range: ±35ppm, -40°C ~85,	1	X100

	crystal oscillator	3225		
6PD7-1861-HLC	Crystal adaptor board	Thickness 0.6mm, FR4 material	1	
6PM7-4067-HTB	DR650-02 TX board	DR650-DVC0-TXBORA D-20130319.PCB, thickness 1.6MM, FR-4, 70X194M, 4 layers	1	
2CC1-16-Y5V160-474Z	R flake multi-layer capacitor	1608, 470nF+80%/-20%, 16V, Y5V	1	R344
2RS1-16-183J	R flake resistor	1608, 18K±5%	1	C339
2CC1-16-C0G500-270J	R flake multi-layer capacitor	1608, 27P±5%, 50V, C0G	1	C137
2RS1-32-000O	R flake resistor	3216, 0Ω±5%	1	U402
2RS1-16-222J	R flake resistor	1608, 2.2K±5%	1	R138
2CC1-16-X7R500-202K	flake multi-layer capacitor	1608, 2000P±10%, 50V, X7R	1	C198
2RS1-16-820J	flake resistor	1608, 82Ω±5%	1	R126
2CC1-16-C0G500-300J	R flake multi-layer capacitor	1608, 30P±5%, 50V, C0G	2	C128, C168
2CC1-16-C0G500-9R0C	R flake multi-layer capacitor	1608, 9P±0.25P, 50V, C0G	1	C134
0SS2-4095-HTA	STR-V TX board plug-in unit	STR-VTX board plug-in unit,pb-free	1	IC102, IC104, IC105, IC302
3CB3-A2548WV-2X10P	Plug-in unit board-to-board connector	2*10 socket(male), interval 2.54mm, 33.02X9X9.1mm, black,	1	J300
3CR7-SMA-50KWE-2	RF coaxial connector	SMA-50KWE-2, 5PIN plug-in unit, 90 degrees, length 23mm.pitch:2.54mm,	1	J200



**Table 2 Part List(TX Module Section)**

Part No.	Part Name	Specification	Quantity	Location
3FW1-42932-30 2320	R SMD fuse	429003/433003/466003, 3216,3A/32V	1	CB400
1DR1-MM3Z12V T1G	Anti-static zener diode	MM3Z12VT1G, 3V, SOD323, pb-free	1	D400
1DS1-HSC277	R SMD switchdiode(of f production)	HSC277,1608	1	D100
1DV1-1SV278	R SMD varactor diode	1SV278(T1)	2	D105,D110
1DV1-1SV305	R SMD varactor diode	1SV305	8	D101,D102,D103,D104, D106,D107,D108,D109
1IS1-LM2941S	SMD specialized IC	LM2941S/TO-236, 5PIN, low dropout voltage regulator, pb-free	1	U400
1IS1-SKY72310	PLL chip	SKY72310,24 pin QFN 4mmX4mm pb-free(QFN-N24_B4x4- P0_5), pb-free	1	IC100
1IS1-PGA103	Broad band low noise amplifier	PGA-103+,0.05to4GHz, SOT-89,PACKAGE,Mini- Circuits brand,RoHS	1	IC306
1IS1-TC75S51F	SMD single operational amplifier IC	TC75S51F,SSOP5-P-0.9 5	2	IC300,IC301
1IS1-XC6209F30 2PR	SMD voltage regulator IC	XC6209F302PR, SOT-89-5, 3.0V	1	IC101
1IS1-XC6209F33 2PR	SMD voltage regulator IC	XC6209F332PR, SOT-89-5, 3.3V	1	IC103
1IS1-XC6209F50 2PR	SMD voltage regulator IC	XC6209F502PR, SOT-89-5, 5.0V	4	IC102,IC104,IC105,IC30 2
1TC1-UMC4	R SMD multiunit tube	UMC4,NPN/PNP multiunit tube	1	U100
1TF1-2SJ243	R SMD FET(off production)	2SJ243-SMD	1	Q104
1TT1-2SC3356- R24	R SMD triode (off production)	2SC3356-R24,SOT23,N PN	3	Q105,Q106,Q202
1TT1-2SC4617- R	R SMD triode	2SC4617-R(BR),EMT3	1	Q101
1TT1-DTC114YE	SMD triode	Digital triode	2	Q204,Q400

		DTC114YE-SMD		
1TT1-FMMT717 TA	R SMD triode	FMMT717A,PNP,SOT23	1	Q203
2CC1-16-C0G50 0-100D	R flake multi-layer capacitor	1608,10P±0.5P,50V,C0G	3	C188,C189,C171
2CC1-16-C0G50 0-101J	R flake multi-layer capacitor	1608,100P±5%,50V,C0 G	65	C161,C166,C167,C182, C184,C186,C199,C208, C212,C214,C216,C224, C228,C234,C239,C242, C246,C255,C289,C291, C295,C297,C300,C301, C302,C303,C304,C305, C306,C307,C308,C309, C310,C311,C312,C315, C316,C317,C320,C321, C322,C323,C340,C341, C344,C345
2CC1-16-C0G50 0-102J	flake multi-layer capacitor	1608,1000P±5%,50V,C0 G	8	C175,C240,C325,C329, C332,C334,C342,R333
2CC1-16-C0G50 0-220J	R flake multi-layer capacitor	1608,22P±5%,50V,C0G	1	C230
2CC1-16-C0G50 0-3R0B	Flake multi-layer capacitor	1608,3P±0.1P,50V,C0G	2	C133,C169
2CC1-16-C0G50 0-121J	R flake multi-layer capacitor	1608,120P±5%,50V,C0 G	1	C244
2CC1-16-C0G50 0-180J	R flake multi-layer capacitor	1608,18P±5%,50V,C0G	1	C130
2CC1-16-C0G50 0-1R0B	flake multi-layer capacitor	1608,1P±0.1P,50V,C0G	8	C129,C135,C177,C179, C313,C314,C318,C319
2CC1-16-C0G50 0-430J	R flake multi-layer capacitor	1608,43P±5%,50V,C0G	2	C221,C136
2CC1-16-C0G50 0-470J	R flake multi-layer capacitor	1608,47P±5%,50V,C0G	2	C220,C256
2CC1-16-C0G50 0-471J	R flake multi-layer capacitor	1608,470P±5%,50V,C0 G	4	C105,C107,C108,C127
2CC1-16-C0G50	R flake	1608,11P±5%,50V,C0G	1	C180

0-110J	multi-layer capacitor			
2CC1-16-C0G50 0-680J	R flake multi-layer capacitor	1608,68P±5%,50V,C0G	1	C181
2CC1-16-C0G50 0-5R0B	flake multi-layer capacitor	1608,5P±0.1P,50V,C0G	3	C163,C164,C165
2CC1-16-C0G50 0-620J	flake multi-layer capacitor	1608,62P±5%,50V,C0G	4	C225,C232,C233,C257
2CC1-16-C0G50 0-6R0C	R flake multi-layer capacitor	1608,6P±0.25P,50V,C0G	2	C231,C235
2CC1-16-C0G50 0-150J	R flake multi-layer capacitor	1608,15P±5%,50V,C0G	4	C155,C156,C131,C170
2CC1-16-C0G50 0-820J	R flake multi-layer capacitor	1608,82P±5%,50V,C0G	2	C222,C226
2CC1-16-X7R50 0-103K	R flake multi-layer capacitor	1608,10nF±10%,50V,X7R	30	C101,C103,C116,C118,C122,C125,C139,C141,C143,C145,C147,C149,C152,C154,C245,C253,C290,C292,C296,C298,C326,C335,C343,C400,C401,C402,C404,C406,C407,C408
2CC1-16-X7R50 0-332K	flake multi-layer capacitor	1608,3300P±10%,50V,X7R	1	C336
2CC1-16-X7R50 0-333K	R flake multi-layer capacitor	1608,33nF±10%,50V,X7R	1	C327
2CC1-16-Y5V16 0-104Z	flake multi-layer capacitor	1608,100nF+80%/-20%,16V,Y5V	19	C110,C112,C114,C158,C159,C162,C185,C187,C195,C196,C209,C213,C215,C217,C227,C229,C238,C241,C243
2CE1-VS250-10 1M0607D	SMD aluminum electrolytic capacitor	SMD-6.3x7.7mm, 100uF/25V	1	C403
2CT1-TS32-160- 4R7M	R SMD tantalum capacitor	3216,4.7µF±20%,16V,TS series (A level)	1	C178

2CT1-TS32-160-100M	R SMD tantalum capacitor	3216,10 $\mu$ F $\pm$ 20%,16V,TS series (A level)	21	C100,C104,C115,C120,C121,C126,C252,C254,C282,C283,C284,C285,C286,C287,C288,C293,C294,C299,C328,C333,C405
2CT1-TS32-350-R10M	R SMD tantalum capacitor	3216,0.1 $\mu$ F $\pm$ 20%,35V,TS series (A level)	3	C172,C173,C174
2CC1-16-C0G500-240J	R flake multi-layer capacitor	1608,24P $\pm$ 5%,50V,C0G	3	C176,C183,C132
2CT1-TS32-6R3-150M	R SMD tantalum capacitor	3216,15 $\mu$ F $\pm$ 20%,6.3V,TS series (A level)	1	C109
2LL1-16-3R3K	R laminated inductor	1608,3.3 $\mu$ H $\pm$ 10%(MLF1608A3R3K TA00)	2	L105,L117
2LW1-16UC-181J	SMD wire winding inductor	1608,180nH $\pm$ 5%, ceramic core (C1608CB-R18J)	1	L205
2LW1-16UC-560G	SMD wire winding inductor	1608,56nH $\pm$ 2%, ceramic core (C1608CB-56NG)	1	L113
2LW1-16UC-R33G	SMD wire winding inductor	1608,330nH $\pm$ 2%(C1608BR33G), pb-free	6	L103,L104,L111,L115,L116,L120
2LW1-20UC-102J	SMD wire winding inductor	2012,1 $\mu$ H $\pm$ 5%, ceramic core (C2012C-1R0J)	2	L214,L106
2LW1-20UC-470GB	SMD wire winding inductor	2012, 47nH $\pm$ 2%, 500mA,LQW2BAS47NG00 ,muRata brand	1	L119
2LW1-20UC-560JA	R SMD wire winding inductor	2012,56nH $\pm$ 5%, ceramic core (C2012C-56NJ)	2	L209,L210
2LW1-20UC-221J	R SMD wire winding inductor	2012,220nH $\pm$ 5%, ceramic core (LQN21AR22J/LQW2BHN22J03L)	1	L118
2LW1-20UC-330GC	SMD wire winding inductor	2012, 33nH $\pm$ 2%, 500mA,LQW2BAS33NG00, SMD wire winding inductor,muRata brand	1	L107
2LW1-25UC-103J	R SMD wire winding inductor	2520,10 $\mu$ H $\pm$ 5%, ceramic core (FLM2520-100J)	1	L122

2RE1-16-1000	SMD precision resistor	1608,100Ω±1%	11	R129,R124,R105,R106, R113,R115,R117,R119, R120,R121,R128
2RE1-16-1001	SMD precision resistor	1608,1K±1%	2	R134,R135
2RE1-16-1200	SMD precision resistor	1608,120Ω±1%	1	R108
2RE1-16-8201	R SMD precision resistor	1608,8.2K±1%	2	R342,R403
2RS1-16-0000	R flake resistor	1608,0Ω	21	C191,R131,R137,R335, R122,R123,R130,R210, L211,R325,R326,R334, R346,R348,R319,R320, R350,R313,R314,R315, R316
2RS1-16-103J	R flake resistor	1608,10K±5%	9	R114,R132,R133,R140, R141,R142,R143,R144, R145
2RS1-16-104J	R flake resistor	1608,100K±5%	6	R100,R103,R107,R111, R118,R127
2RS1-16-123J	R flake resistor	1608,12K±5%	2	R343,R337
2RS1-16-124J	R flake resistor	1608,120K±5%	2	R339,R341
2RS1-16-220J	R flake resistor	1608,22Ω±5%	1	R218
2RS1-16-221J	R flake resistor	1608,220Ω±5%	2	R211,R212
2RS1-16-270J	R flake resistor	1608,27Ω±5%	2	R209,R125
2RS1-16-302J	flake resistor	1608,3K±5%	2	R104,R116
2RS1-16-472J	R flake resistor	1608,4.7K±5%	2	R101,R109
2RS1-16-473J	R flake resistor	1608,47K±5%	5	R345,R110,R220,R400, R401
2RS1-16-511J	flake resistor	1608,510Ω±5%	1	R219
2RS1-16-563J	R flake resistor	1608,56K±5%	1	R207
2RS1-16-682J	R flake resistor	1608,6.8K±5%	2	R102,R112
2RS1-20-0000	R flake resistor	2012,0Ω	2	L212,L213
5FE1-BLM11A60	R SMD EMI	1608,BLM11A601S/BLM	28	L100,L101,L102,L108,L1

1S	suppression filter	18AG601S(0138-05)		09,L110,L112,L114,L121,L123,L202,L207,L300,R301,L301,R302,R303,R304,R305,R306,R307,R308,R309,R310,R311,R312,R329,R351
5FE1-BLM21P300S	R SMD EMI suppression filter	2012,BLM21P300S/BLM21PG300S(0149-05)	1	L400
5OT1-12R8-ACL4-3225	SMD temperature compensated crystal oscillator	KDS,12.8MHz±1.5ppm, Vc=1.5±1V range:±35ppm,-40℃~85,3225	1	X100
6PD7-1861-HLC	Crystal adaptor board	Thickness 0.6mm,FR4 material	1	
6PM7-4067-HTB	DR650-02 TX board	DR650-DVC0-TXBORAD-20130319.PCB, thickness1.6MM,FR-4,70X194M,4layers	1	
2CC1-16-Y5V160-474Z	R flake multi-layer capacitor	1608,470nF+80%/-20%, 16V,Y5V	1	R344
2RS1-16-183J	R flake resistor	1608,18K±5%	1	C339
2CC1-16-C0G500-270J	R flake multi-layer capacitor	1608,27P±5%,50V,C0G	1	C137
2RS1-32-000O	R flake resistor	3216,0Ω±5%	1	U402
2RS1-16-222J	R flake resistor	1608,2.2K±5%	1	R138
2CC1-16-X7R500-202K	flake multi-layer capacitor	1608,2000P±10%,50V,X7R	1	C198
2RS1-16-820J	flake resistor	1608,82Ω±5%	1	R126
2CC1-16-C0G500-300J	R flake multi-layer capacitor	1608,30P±5%,50V,C0G	2	C128,C168
2CC1-16-C0G500-9R0C	R flake multi-layer capacitor	1608,9P±0.25P,50V,C0G	1	C134
0SS2-4095-HTA	STR-V TX board plug-in unit	STR-V, pb-free	1	IC102,IC104,IC105,IC302
3CB3-A2548WV-	Plug-in	2*10 socket(male),	1	J300

2X10P	board-to-board connector	interval 2.54mm,33.02X9X9.1mm,black		
3CR7-SMA-50KWE-2	RF coaxial connector	SMA-50KWE-2, 5PIN plug-in unit, 90 degrees h:2.54mm	1	J200

### Table 3 Part List(Power Amplification Module Section)

Part No.	Part Name	Specification	Quantity	Location
3FW1-42932-302320	R SMD fuse	429003/433003/466003, 3216,3A/32V	1	CB300
2CE1-VS250-101M0607D	SMD aluminum electrolytic capacitor	SMD-6.3x7.7mm, 100uF/25V	3	C100,C105,C203
2CC1-16-C0G500-101J	R flake multi-layer capacitor	1608,100P±5%,50V,C0G	37	C101,C103,C106,C108, C110,C112,C113,C114, C116,C121,C122,C123, C124,C137,C139,C150, C161,C164,C167,C300, C301,C302,C303,C304, C305,C306,C307,C308, C309,C310,C311,C312, C313,C314,C315,C316, C317
2CC1-16-Y5V160-104Z	flake multi-layer capacitor	1608,100nF+80%/-20%, 16V,Y5V	10	C102,C104,C107,C109, C115,C129,C138,C140, C142,C143
2CT1-TS32-160-100M	R SMD tantalum capacitor	3216,10µF±20%,16V,TS series (A level)	4	C111,C136,C163,C166
2CC1-16-C0G500-160J	R flake multi-layer capacitor	1608,16P±5%,50V,C0G	1	C117
2CC1-32-C0G102-5R0J	R flake multi-layer capacitor	3216,5P±5%,1000V,C0G	1	C118
2CC1-32-C0G102-6R0J	R flake multi-layer capacitor	3216,6P±0.25P,1000V,C0G	1	C119
2CC1-32-C0G102-4R0J	R flake multi-layer	3216,4P±0.25P,1000V,C0G	1	C120

	capacitor			
2CC1-32-C0G50 0-120J	flake multi-layer capacitor	3216,12P±5%,50V,C0G	2	C132,C135
2CC1-32-C0G50 0-270J	flake multi-layer capacitor	3216,27P±5%,50V,C0G	2	C133,C134
2CC1-16-C0G50 0-330J	flake multi-layer capacitor	1608,33P±5%,50V,C0G	4	C144,C146,C168,C169
2CC1-32-C0G10 1-102J	flake multi-layer capacitor	3216,1000P±5%,100V,C 0G,GRM3195C2A102JA 01D	3	C125,C126,C160
2CC1-16-C0G50 0-220J	R flake multi-layer capacitor	1608,22P±5%,50V,C0G	4	C127,C128,C130,C131
2CC1-16-C0G50 0-471J	R flake multi-layer capacitor	1608,470P±5%,50V,C0 G	8	C141,C145,C147,C152, C154,C155,C156,C157
2CC1-16-C0G50 0-102J	flake multi-layer capacitor	1608,1000P±5%,50V,C0 G	1	C148
2CC1-16-C0G50 0-221J	R flake multi-layer capacitor	1608,220P±5%,50V,C0 G	1	C149
2CC1-16-X7R50 0-103K	R flake multi-layer capacitor	1608,10nF±10%,50V,X7 R	10	C153,C162,C165,C200, C201,C202,C204,C206, C207,C208
2CT1-TS32-100- 220M	SMD tantalum capacitor	3216,22µF±20%,10V,TS series (A level)	1	C205
1DR1-MM3Z15V T1G	SMD anti-static zener diode	MM3Z2V4T1 TS series, 15V,W=1.2mm,L=2.5mm ,H=1.0mm, pb-free	3	D100,D101,D200
1DZ1-HZU5ALL	R SMD voltage regulator diode (off production)	HZU5ALL,2012,5V	1	D102
1DS1-RB706F-4 0	R SMD switch diode	Schottky diode RB706F-40,SOT-323	2	D103,D104
1DR1-XBS053V 15R-1G	SMD schottky diode	XBS053V15R-1G, SOD-523 package, VR=20V,VF=0.40V, pb-free	2	D201,D202
1IL1-NJM2904V	R SMD linear IC	Double operational amplification	1	IC100



		NJM2904V,TSSOP-8		
5FE1-BLM41P600SPT	R SMD EMI suppression filter	EMI,FILTER, SMT,BLM41P600SPT,1206, pb-free	3	L100,L101,L102
5FE1-BLM11A601S	R SMD EMI suppression filter	1608,BLM11A601S/BLM18AG601S(0138-05)	11	L103,L110,R300,R301,R302,R303,R304,R305,R308,R309,R310
2LW1-20UC-68NG	SMD wire winding inductor	2012,68nH±2% wire winding inductor,SAGAMI,C2012C-68NG	1	L104
2LH1-R903R0-L05-05	R SMD air core inductor	Wire diameter φ0.9, internal diameter φ3.0,5 circles, pin height 0.5mm, backward winding	3	L107,L108,L109
2RS1-16-471J	R flake resistor	1608,470Ω±5%	1	L111
2LH1-R903R0-L11-05	R SMD air core inductor	Wire diameterφ0.9, internal diameterφ3.0,11 circles, pin height 0.5mm, backward winding	1	L112
2CC1-32-C0G500-102J	Flake multi-layer capacitor	3216,1000P±5%,50V,C0G	1	L113
2LL1-16-47NJ	R laminated inductor	1608,47nH±5%(MLG1608B47NJ)	4	L105,L106,L114,L115
5FE1-BLM21P300S	R SMD EMI suppression filter	2012,BLM21P300S/BLM21PG300S(0149-05)	1	L200
1TT1-FMMT717TA	R SMD triode	FMMT717A,PNP,SOT23	2	Q100,Q103
1TT1-DTC114YE	SMD triode	Digital triode DTC114YE-SMD	3	Q101,Q104,Q200
1TT1-2SC3357	R SMD triode (off production)	2SC3357(RE),SOT89(NEC)	1	Q102
2RS1-16-473J	R flake resistor	1608,47K±5%	9	R100,R118,R133,R200,R201,R6042,R6043,R6052,R6053
2RS1-16-561J	R flake resistor	1608,560Ω±5%	2	R101,R119
2RE1-16-8201	R SMD precision resistor	1608,8.2K±1%	2	R102,R203

2RS1-16-680J	R flake resistor	1608,68Ω±5%	2	R105,R115
2RE1-16-1501	R SMD precision resistor	1608,1.5K±1%	1	R106
2RS1-16-270J	R flake resistor	1608,27Ω±5%	2	R108,R109
2RS1-16-221J	R flake resistor	1608,220Ω±5%	4	R110,R111,R112,R114
2RS1-16-000O	R flake resistor	1608,0Ω	8	R130, R113,R128,R141,R143, R146,R147,R311
2RS1-16-222J	R flake resistor	1608,2.2K±5%	1	R120
2RS1-16-103J	R flake resistor	1608,10K±5%	6	R121,R123,R125,R129, R140,R307
2RS1-16-102J	R flake resistor	1608,1K±5%	1	R124
2RS1-16-202J	R flake resistor	1608,2K±5%	1	R126
2RS1-16-104J	R flake resistor	1608,100K±5%	1	R127
2RS1-16-821J	R flake resistor	1608,820Ω±5%	1	R131
2RS1-16-510J	R flake resistor	1608,51Ω±5%	1	R134
2RS1-16-512J	flake resistor	1608,5.1K±5%	2	R137,R138
2RE1-16-1000	SMD precision resistor	1608,100Ω±1%	1	R142
1IS1-XC6701D3 32PR	3.3VLDO	28V high voltage input, high-speed and low consumption LDO, 3.3V output, package: SOT-89	1	U102
1IS1-LM2941S	SMD specialized IC	LM2941S/TO-236, 5PIN, low dropout voltage regulator, pb-free	1	U200
6PM7-4071-HPA	SEPURA power amplification board PCB	power amplification board PCB, four layers, FR4,58.24X70, RFAMPLIFIER-2013071 9.PCB, pb-free	1	
2RS1-16-331J	R flake resistor	1608,330Ω±5%	2	R135, R122
1IM1-AT24C08C N-SH	E R SMD memorizer IC	EEPROM,AT24C08CN -SH(8-SOIC)	1	IC6005

	for analog commercial portable and mobile			
0SS2-4071-HPC	STR-U power amplification board plug-in unit (130722)	STR-U power amplification board plug-in unit, pb-free	1	
3CB1-DC002	STR-U power amplification board power supply socket	DC-002, combination key, plastic pedestal+ two copper tablets, pb-free	1	J302
3CP3-LCP200	DM850 power supply socket	LCP with plastic pedestal with ,2Pin, nickel-plated brass pin, pb-free	1	
7MBC-4073-01A-N	STM-U power connecting terminal	nickel-plated brass, pb-free	2	
2RV3-22ZR-10D	R plug-in unit piezoresistor	22ZR-10D	1	R306
3CR7-SMA-50KWE-2	RF coaxial connector	SMA-50KWE-2, 5PIN plug-in unit, 90 degrees, length 23mm.pitch:2.54mm	1	J100
3CB3-A2548WV-2X05P	Plug-in unit board-to-board connector	A2548WV-2X05P, male, 180 degrees, interval 2.54mm,20.32mmX9mm X9.1mm,	1	J300
1IS3-DS18B20	Integrated IC	Plug-in unit temperature sensor ,3.0V-5.5V power supply, -55°C--125°C,TO-92	1	IC101

**Table 4 Part List(Baseband Board)**

Part No.	Part Name	Quantity	Location
3CB3-VH3096-2P	DC supply socket	1	J1
3CB3-S6160BK1	Plug-in unit board-to-board connector	2	J2
3CR7-SMA-50KE	RF coaxial connector	3	J6, J7, J8
3CB3-A2548WV-2X05P	Plug-in unit board-to-board	4	J5, J18, J19, J23

	connector		
3CB3-A2548WV-2X13P	Plug-in unit board-to-board connector	2	J9, J15
3CT3-KRJ003NL-8P	Crystal head RJ45 socket	1	J12
3CB3-A2548WV-2X10P	Plug-in unit board-to-board connector	1	J17
3CL3-PH-20002	FPC connector	1	J20
3CL3-PH-25402A	FPC connector	1	J27
2RV3-22ZR-10D	Plug-in unit piezoresistor	1	R2
2CE3-GM350-102M1320	Plug-in unit aluminum electrolytic capacitor	2	C331, C522
3CL3-PH-20003	FPC connector	1	J21
2LI3-0911-331K	Plug-in unit I-shaped inductor	3	L12, L16, L17
7MBC-4073-04A-W	Major shielding cover	4	P1, P2, P4, P5
7MBC-4073-05A-W	Minor shielding cover	1	P3
6BLS-4814-03327U	SMD button battery	1	BT2
2CC1-16-X7R500-103K	Flake multi-layer capacitor	1	C1
2CC1-32-Y5V500-106Z	flake multi-layer capacitor	23	C2, C6, C21, C24, C29, C30, C31, C109, C175, C182, C183, C226, C263, C277, C285, C286, , C251, C275, C288, , C506, C507, C512, C513
2CC1-16-Y5V500-104Z	flake multi-layer capacitor	52	C3, C7, C8, C9, C12, C17, C19, C22, C27, C90, C91, , C95, C96, C97, C103, C105, C106, C110, C115, C116, C136, C244, C318, C429, C459, C262, C146, C147, , C170, C171, C172, C174, C177, C178, C180, C181, C194, C195, C205, C206, C225, C264, C265, C279, C282, C290, C291, C294, C297, C299, C302, C304,
2CC1-16-C0G500-101J	flake multi-layer capacitor	32	C245, C517, C518, C519, C520, C521, C531, C532, C519, C520, C381, C385, C283, C284, C295, C300, C4, C35, C36, C37, C48, C60, C75, C148, C246, C309, C327, C345, C371, C374, C508, C514

2CE1-VS250-101M0607D	SMD aluminum electrolytic capacitor	7	C5, C13, C289, C316, C405, C406, C411
2CC1-32-Y5V100-226Z	flake multi-layer capacitor	19	C523, C524, C525, C526, C527, C528, C529, C530, C10, C11, C16, C18, C26, C107, C111, C113, C142, C145, C428
2CC1-16-X7R500-102K	flake multi-layer capacitor	3	C14, C20, C388
2CC1-16-C0G500-470J	flake multi-layer capacitor	1	C15
2CC1-16-Y5V250-105Z	flake multi-layer capacitor	50	C292, C293, C25, C66, C67, C68, C81, C82, C83, C100, C108, C114, C117, C122, C123, C124, C143, C144, C154, C155, C156, C187, C188, C189, C190, C191, C200, C201, C202, C203, C204, C266, C267, C268, C269, C271, C273, , C276, C278, C281, C287, C112, C137, C234, C235, C324, C332, C298, C511, C460
2CC1-16-X7R100-225K	flake multi-layer capacitor	1	C28
2CC1-20-Y5V160-106Z	flake multi-layer capacitor	18	C533, C534, C32, C33, C34, C101, C118, C119, C120, C121, C138, C139, C176, C179, , C242, C319, C325, C369
2CC1-16-C0G500-100D	flake multi-layer capacitor	8	C38, C39, C49, C61, C76, C92, C93, C149
2CC1-16-X5R6R3-475K	flake multi-layer capacitor	23	C384, C380, C50, C51, C52, C53, C62, C63, C64, C65, C77, C78, C79, C80, C150, C151, C152, C153, C198, C199, C218, C228, C236
2CC1-16-C0G500-270J	flake multi-layer capacitor	1	C102
2CC1-16-C0G500-4R5C	flake multi-layer capacitor	1	C104
2CC1-32-C0G102-102J	flake multi-layer capacitor	1	C173
2CC1-16-C0G500-221J	flake multi-layer capacitor	3	C184, C185, C186
2CC1-16-C0G500-330J	flake multi-layer capacitor	29	C306, C382, C386, C207, C208, C209, C210, C213, C214, C215, C220, C221, C222, C223, C224, C247, C248, C249, C252, C255, C258, C259, C317, C326, C372,

			C375, C377, C509, C515
2CC1-16-X7R500-471K	flake multi-layer capacitor	15	C387, C383, C280, C370, C373, C376, C378, C379, C407, C408, C409, C410, C427, C510, C516
2CC1-10-X7R160-104K	flake multi-layer capacitor	126	C40, C41, C42, C43, C44, C45, , C54, C55, C56, C57, C58, C59, C69, C70, C71, C72, C73, C74, C84, C85, C86, C87, C88, C89, C94, C98, C99, C125, C126, C127, C128, C129, C130, C131, C132, C133, C134, C135, C140, C141, C157, C158, C159, C160, C161, C162, C163, C164, C165, C166, C167, C168, C169, C270, C461, C462, C463, C464, C465, C466, C467, C468, C469, C470, C471, C472, C473, C474, C475, C476, C477, C478, C479, C480, C481, C482, C483, C484, C485, C486, C487, C488, C489, C490, C491, C492, C493, C494, C495, C496, C497, C498, C499, C500, C430, C431, C432, C433, C434, C435, C436, C437, C438, C439, C440, C441, C442, C443, C444, C447, C504, C505, C448, C449, C450, C451, C452, C453, C454, C455, C456, C457, C458, C501, C502, C503
2CC1-10-C0G500-271J	flake multi-layer capacitor	35	C46, C47, C227, C229, C230, C231, C232, C233, , C238, C239, C240, C315, C321, , C333, C334, C335, C336, C337, C338, C339, C340, C341, C342, C343, C344, , C346, C347, C348, C349, C350, C351, C352, C353, C354, C357
2CC1-10-C0G500-471J	flake multi-layer capacitor	31	C389, C390, C391, C392, C393, C394, C395, C396, C397, C398, C399, C400, C401, C402, C403, C404, C412, C413, C414, C415, C416, C417, C418, C419, C420, C421, C422, C423, C424, C425, C426
1DG1-DSM3MA1	SMD conventional diode	1	D2
1DR1-SMCJ20A	SMD diode	1	D1

1DR1-SS36	SMD commutation diode	1	D3
1DS1-DA2S10100L	SMD switch diode	4	D8, D11, D12, D13
1DS1-HVC131	SMD switch diode	2	D9, D15
1DP1-BV03C	TVS diode	1	D10
1DS1-DAN222	SMD switch diode	1	D14
1DR1-MMBZ20VALT1G	TVS diode	6	D16, D17, D18, D19, D20, D5
1TT1-2SA1641-S	SMD triode	1	Q42
1DS1-DA204U	SMD switch diode	2	D7, D21
5FE1-BLM15AG221SN1D	EMI suppression filter	50	FB1, FB2, FB3, FB4, FB5, FB17, FB18, , FB25, FB26, FB27, FB28, FB29, FB30, FB31, FB35, FB36, FB37, FB38, FB39, FB40, FB41, FB42, FB43, FB44, FB45, FB46, FB47, FB48, FB49, FB50, FB51, FB52, FB53, FB54, FB55, FB56, FB57, FB58, FB59, FB60, FB62, FB63, FB64, R77, R84, R85, R86, R87, R88, R89
5FE1-BLM41P600SPT	EMI suppression filter	7	L8, L10, L11, FB20, FB22, L14, L15
5FE1-BLM18PG181SN1	EMI suppression filter	16	FB6, FB7, FB8, FB9, FB10, FB11, FB12, FB13, FB14, FB15, FB19, FB21, FB24, FB61, FB33, FB34
2RS1-16-0000	Flake resistor	18	C241, C320, R208, R231, R332, R213, R217, FB16, R22, R24, R209, R210, R214, R224, R225, R94, R107, R109
3FW1-42932-302320	SMD fuse	1	F1
4PE1-16-F5	SMD LED	4	LED2, LED3, LED4, LED5
4PE1-16-F2	SMD LED	1	LED6
2LG1-NR8040T842-4R7S	SMD power inductor	1	L1
2LG1-SWPA4020-2R2S	SMD power inductor	4	L2, L3, L4, L6
2LW1-16UC-221J	SMD wire winding inductor	1	L5
2LW1-20UC-180J	SMD wire winding inductor	2	L7, L33
2LW1-20UC-220J	SMD wire winding inductor	2	L13, L32
2LW1-16UC-181J	SMD wire winding inductor	2	L22, L26
2LW1-16UC-221G	SMD wire winding inductor	1	L24
2LW1-16UC-271G	SMD wire winding	1	L25

	inductor		
2LI1-1608-R47G	I-shaped inductor	2	L21, L23
2LW1-25UC-681JA	SMD wire winding inductor	1	L20
1TT1-DTC114YE	SMD triode	18	Q1, Q2, Q5, Q8, Q10, Q12, Q13, Q14, Q15, Q16, Q17, Q18, Q19, Q20, Q21, Q22, Q23, Q24
1TT1-MMBT3904	SMD triode	2	Q3, Q9
2RE1-16-49R9	SMD precision resistor	4	R160, R166, R167, R168
2RE1-16-1001	SMD precision resistor	2	R32, R33
2RE1-16-2001	SMD precision resistor	1	R4
2RS1-16-332J	Flake resistor	4	R179, R293, R294, R363
2RE1-16-4871	SMD precision resistor	1	R172
2RE1-16-8201	SMD precision resistor	1	R18
2RE1-16-1002	SMD precision resistor	3	R1, R120, R121
2RE1-16-4302	SMD precision resistor	2	R13, R366
2RE1-16-18R0	SMD precision resistor	3	R28, R29, R95
2RS1-16-303J	Flake resistor	1	R5
2RS1-16-100J	Flake resistor	2	R6, R302
2RS1-16-103J	Flake resistor	56	R7, R8, R9, R10, R14, R15, R16, R17, R19, R20, R21, R23, R25, R26, R53, R54, R56, R57, R163, R174, R175, R176, R177, R182, R183, R186, R187, R188, R189, R190, R192, R193, R195, R196, R197, R198, R232, R259, R118, , R199, R200, R201, , R206, R211, R228, R230, R295, R296, R298, R299, R301, R303, R327, R353, R355, R367
2RS1-16-510J	Flake resistor	1	R27
2RS1-16-472J	Flake resistor	10	C260, C261, R133, R134, R138, R140, R161, R169, R202, R203
2RS1-16-330J	Flake resistor	55	R123, R215, R218, R223, R237, R238, R239, R240, R241, R242, R243, R244, R245, R246, R247, R248, R249, R250, R251, R252, R254, R279, R280, R281, R282, R283, R285, R286, R288, R289, R146, R147, R148, R149, R164, R165, R171, R207, R229, R291, R305, R306, R307, R308, R309, R310, R311, R312, R313, R314, R315, R348, R350, R362, C296
2RS1-16-101J	Flake resistor	11	R142, R143, R59, R105, R106,



			R180, C272, R92, R93, C274, FB32
2RS1-16-681J	Flake resistor	1	R233
2RS1-16-473J	Flake resistor	2	R119, R300
2RS1-16-102J	Flake resistor	14	R91, R97, R98, R99, , R137, R156, R157, R158, R159, R219, R253, R304, R329, R333
2RS1-16-222J	Flake resistor	5	R122, R170, R290, R292, R364
2RS1-16-755J	Flake resistor	1	R173
2RS1-16-104J	Flake resistor	1	R205
2RS1-16-471J	Flake resistor	2	R220, R222
2RS1-10-000O	Flake resistor	4	R260, R51, R96, R41
2RS1-10-330J	Flake resistor	26	R64, R73, R74, R75, R76, R78, R79, R101, R102, R108, R36, R37, R39, R40, R42, R43, R126, R127, R135, R136, , R150, R151, R152, R153, R154, R155
2RS1-10-101J	Flake resistor	3	R103, R104, R111
2RS1-10-472J	Flake resistor	9	R60, R61, R62, R63, R34, R38, R80, R81, R145
2RS1-10-103J	Flake resistor	21	R45, R46, R47, R48, R49, R50, R65, R66, R67, R72, R114, R116, R124, R125, R128, R129, R130, R131, R132, R204, R115
1IS1-TPS54331DDA	SMD switch power IC	1	U1
1IS1-TPS65023	Power management chip	1	U2
1IS1-LM2941S	SMD specialized IC	1	U3
1IP1-OMAPL138BZWT3	Dual-core CPU	1	U4
1IM1-MT47H64M16	SMD memorizer IC	1	U6
1IM1-K9GAG08U0M-I	SMD memorizer IC	1	U7
1IS1-TPS2051BDGN	LDO power voltage regulator IC	1	U8
1IS1-RT9193-33PB	SMD voltage regulator IC	1	U12
1IS1-RT8008GB	SMD voltage reduction IC	1	U13
1IS1-EP4CE30F23I7N	SMD specialized IC	1	U14
1IS1-RT9193-25PB	SMD voltage regulator IC	1	U15
1IS1-DP83848I	SMD specialized IC	1	U17
1DR1-TPD4S012DRY	TVS diode	1	U19
1IS1-ADS1015	AD convertor IC	1	U22
1IS1-TLV5614	DA convertor chip	2	U24, U27
1IS1-LM4040B20IDBZT	SMD voltage	1	U29

	regulator IC		
1IS1-TLV320AIC14	CODEC chip	1	U30
1IS1-TDA8541T	Audio power amplifier IC	1	U31
1IS1-MAX3232ESE	SMD dual channel RS-232 wire driver/receiver IC	1	U32
1IL1-AD8031ARTZ	SMD linear IC	1	U38
1IM1-AT24C08CN-SH	Memorizer IC	1	U23
1IS1-XC6209F302PR	SMD voltage regulator IC	1	U20
1IS1-XC6209F332PR	SMD voltage regulator IC	1	U5
1IS1-XC6209F502PR	SMD voltage regulator IC	1	U26
5XT1-MC146-32R76K	SMD ceramic harmonic oscillator	1	Y1
5OC1-24R0-MML-3225	Crystal Oscillator	1	Y2
5OC1-50R0-MML-3225	Crystal Oscillator	1	Y3
5XC1-18R4-CEC5032SC H	SMD crystal Oscillator	1	Y4
1TF1-ST2301	SMD FET	2	Q7, Q11
5OD1-12R8-AL3-3225	Voltage-controlled temperature-compensated crystal oscillator	1	Y5
1MR3-MAX-6Q	GPS module	1	U9
2RE1-16-1801	SMD precision resistor	1	R365
2CC1-32-Y5V160-106Z	flake multi-layer capacitor	2	C243, C237
2CC1-16-C0G500-7R0C	flake multi-layer capacitor	2	C310, C328
2CC1-16-C0G500-9R0C	flake multi-layer capacitor	2	C311, C445
2CC1-16-C0G500-150J	flake multi-layer capacitor	2	C312, C329
2CC1-16-C0G500-240J	flake multi-layer capacitor	2	C314, C446
2CC1-16-C0G500-390J	flake multi-layer capacitor	2	C313, C330
2CC1-16-C0G500-820J	flake multi-layer capacitor	3	C301, C303, C307
2CC1-16-C0G500-121J	flake multi-layer capacitor	1	C308
2CC1-16-C0G500-151J	flake multi-layer	1	C305

	capacitor		
2RS1-16-301J	Flake resistor	1	R144
3SE1-SDIP-04	SMD DIPdial switch	1	J4
6PM7-4071-HBC	Sepura repeater baseband board PCB	1	

**Table 5 Part List(Front Cover)**

Part No.	Part Name	Quantity	Location
3CB3-A2548WV-2X05P	Plug-in unit board-to-board connector	1	J1
4PE3-0705-F4	Plug-in unit LED	8	LED1, LED2, LED3, LED4, LED5, LED6, LED7, LED9
4PE3-0705-F2	Plug-in unit LED	1	LED8
2CC1-16-Y5V500-104Z	Flake multi-layer capacitor	1	C1
5FE1-BLM18PG181SN1	SMD EMI suppression filter	1	FB1
1TT1-DTC114YE	SMD triode	8	Q1, Q2, Q3, Q4, Q5, Q6, Q7, Q8
2RS1-16-330J	Flake resistor	8	R1, R2, R3, R4, R5, R6, R7, R8
2RS1-16-102J	Flake resistor	1	R16
2RS1-16-101J	Flake resistor	8	R9, R10, R11, R12, R13, R14, R15, R17
6PD7-4071-HFB	Sepura repeater frontcover PCB	1	

**Table 6 Part List(Power Board)**

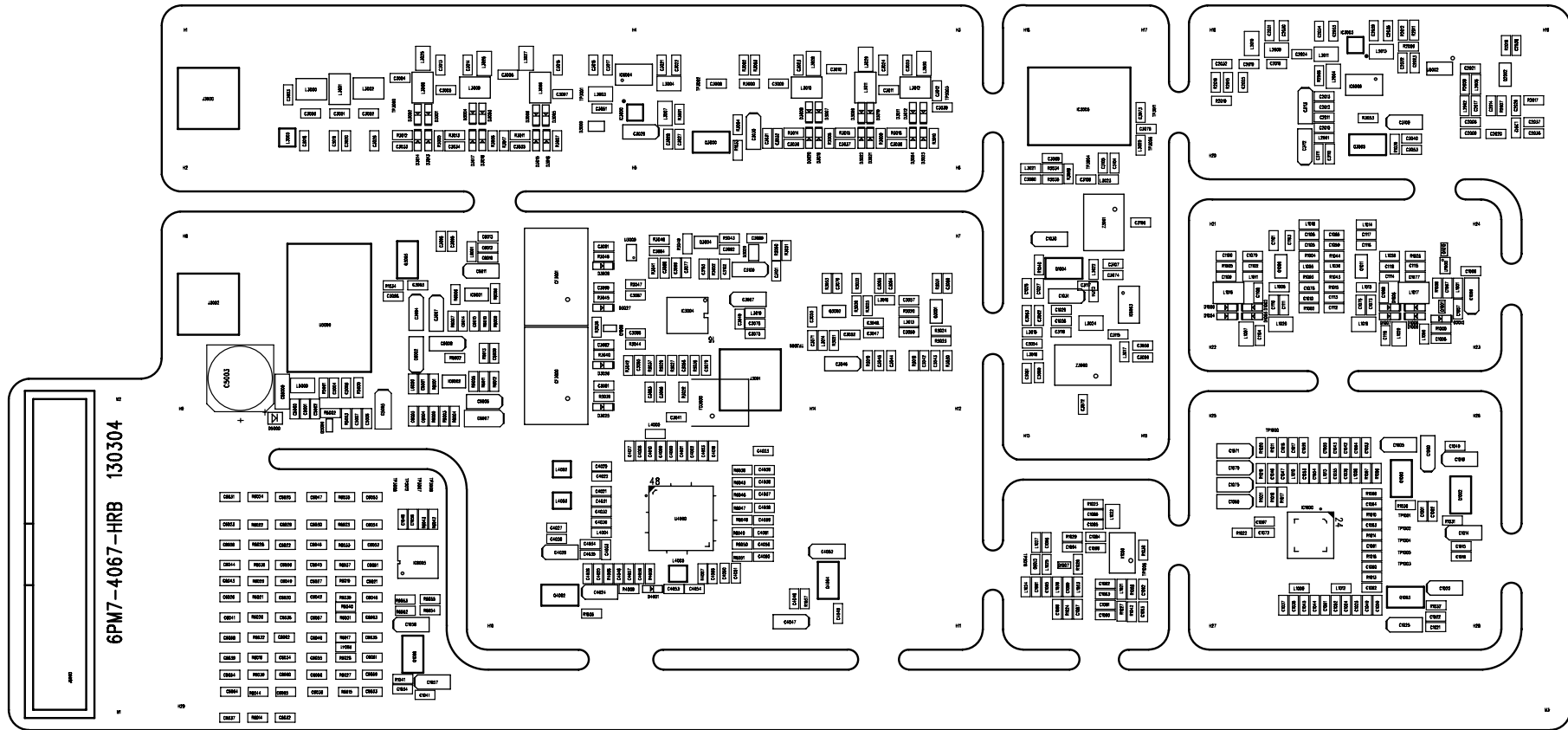
Part No.	Part Name	Quantity	Location
2CE3-GM350-102M1320	Plug-in unit aluminum electrolytic capacitor	2	C1, C2
3SJ3-G8P-1C4P-12VDC	Plug-in unit power relay	2	U1, U2
3WPC-KF65-4P	Plug-in unit connecting terminal	1	J1
3WPC-KF65-2P	Plug-in unit connecting terminal	2	J2, J3
3CL3-PH-25402A	FPC connector	2	J4, J5
5FE1-BLM18PG181SN1	SMD EMI suppression filter	1	R1
2RS1-16-471J	Flake resistor	1	R3

1DZ1-LM3Z18VT1G	SMD voltage regulator diode	1	D1
1DS1-DA2S10100L	SMD switch diode	1	D2
1TT1-MMBT3904	SMD triode	2	Q1, Q2
2RS1-16-103J	Flake resistor	1	R5
2RS1-16-102J	Flake resistor	1	R6
2CC1-16-X7R500-103K	flake multi-layer capacitor	1	C3
6PD7-4071-HWB	STR-U repeater power board PCB	1	

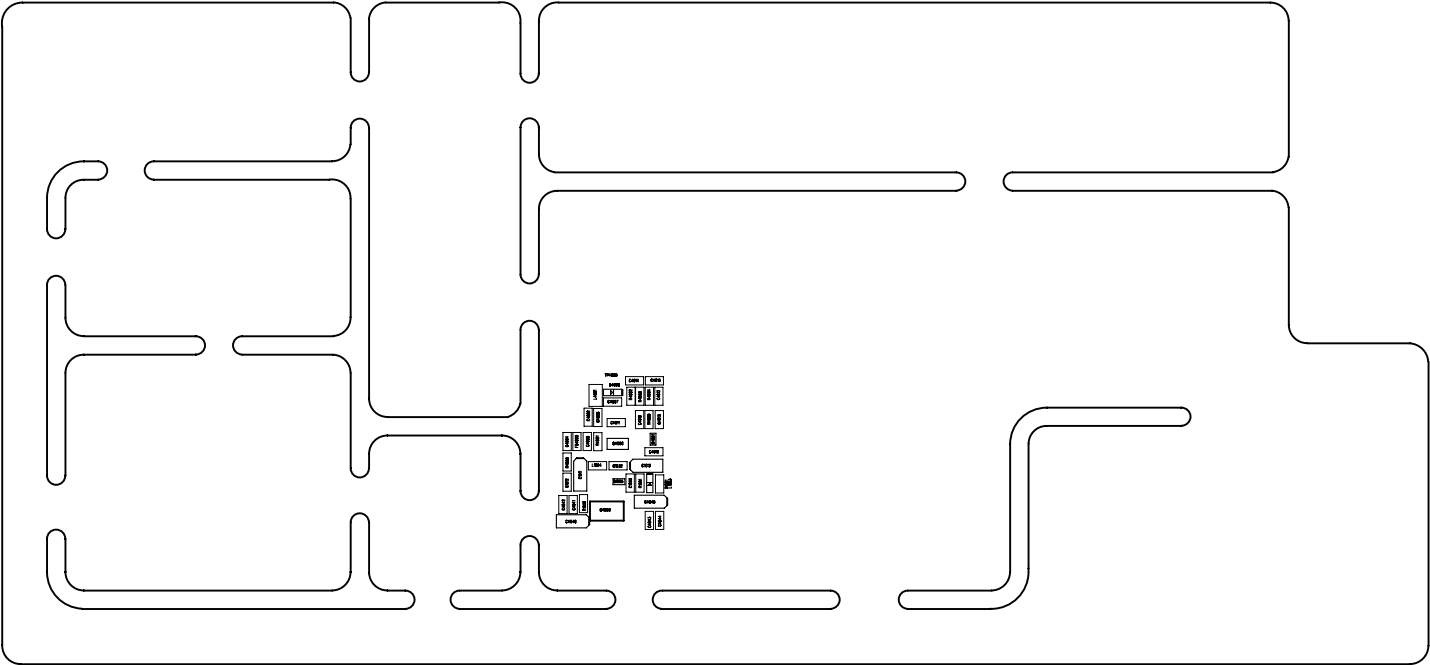
### Table 7 Part List(Accessory Board)

Part No.	Part Name	Quantity	Location
3WPC-VGA-26PB	26 pins VGA female socket	1	J9
3CB3-A2548WV-2X13P	Plug-in unit board-to-board connector	1	J10
6PD7-4071-HL1A	STR-U repeater accessory board PCB	1	

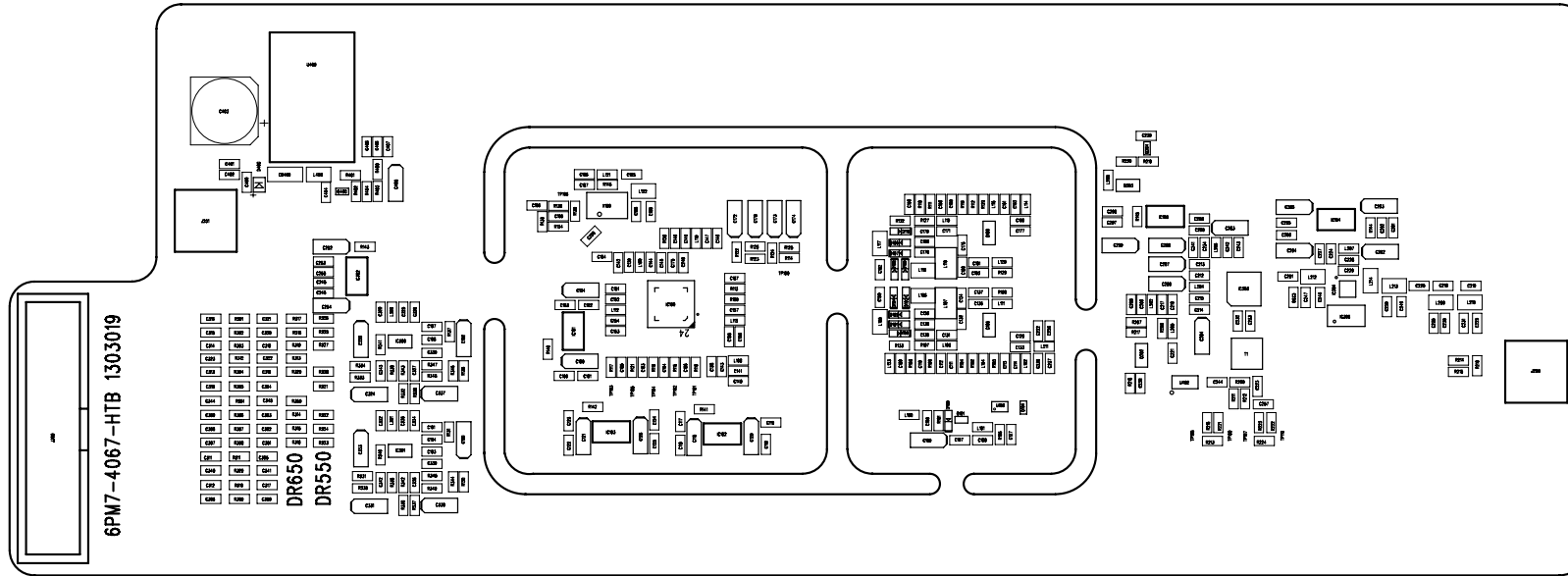
# Figure 1 Rx module Top Board Position Mark Diagram



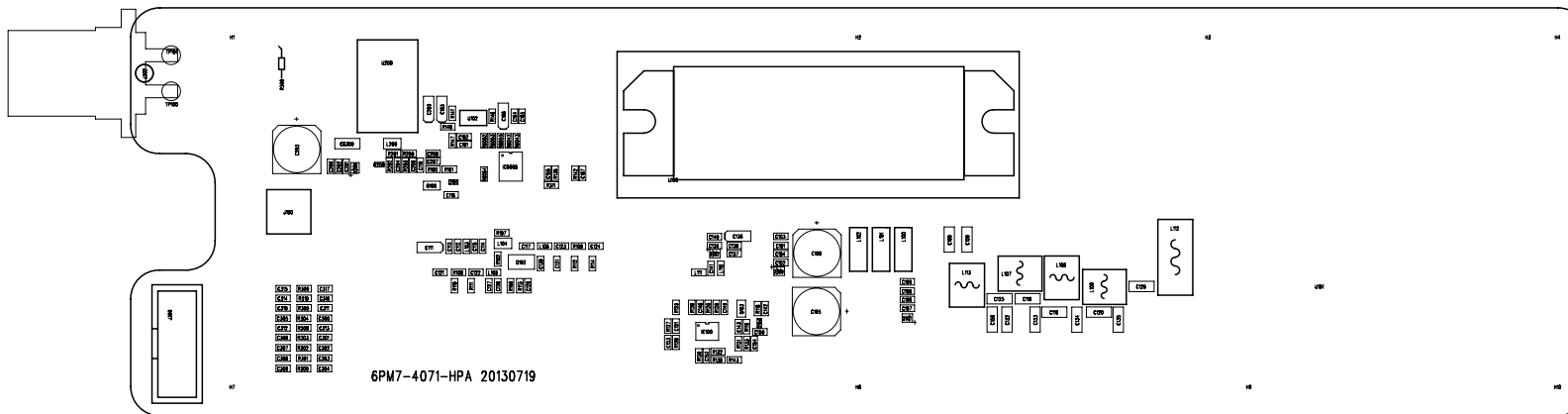
# Figure 2 Rx Module Bottom Board Position Mark Diagram



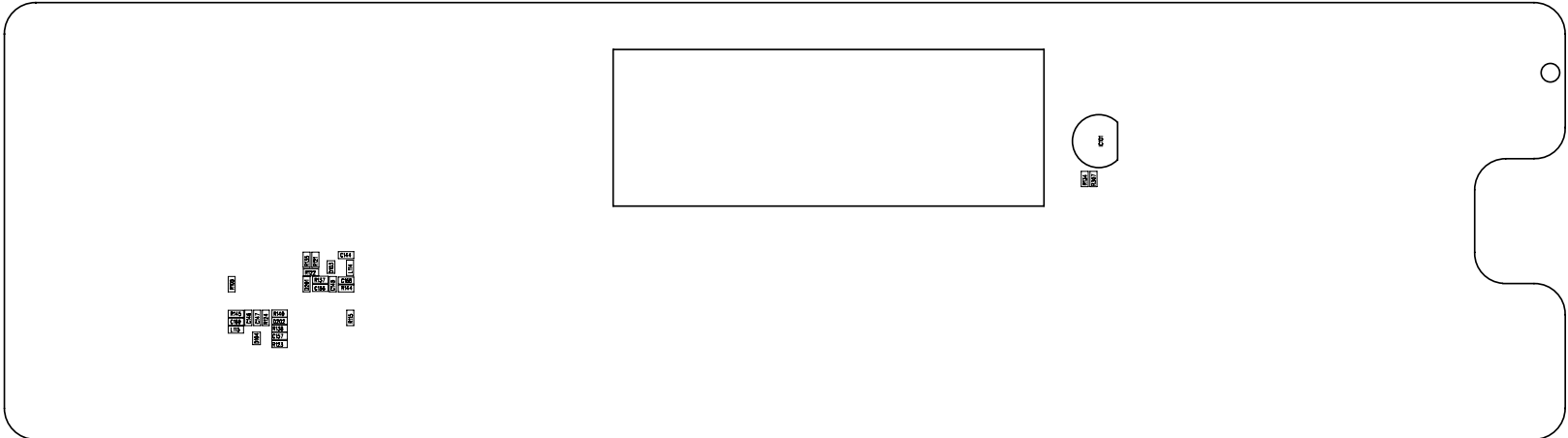
### Figure 3 Tx Module Top Board Position Mark Diagram



### Figure 4 Power Amplifier Module Top Board Position Mark Diagram



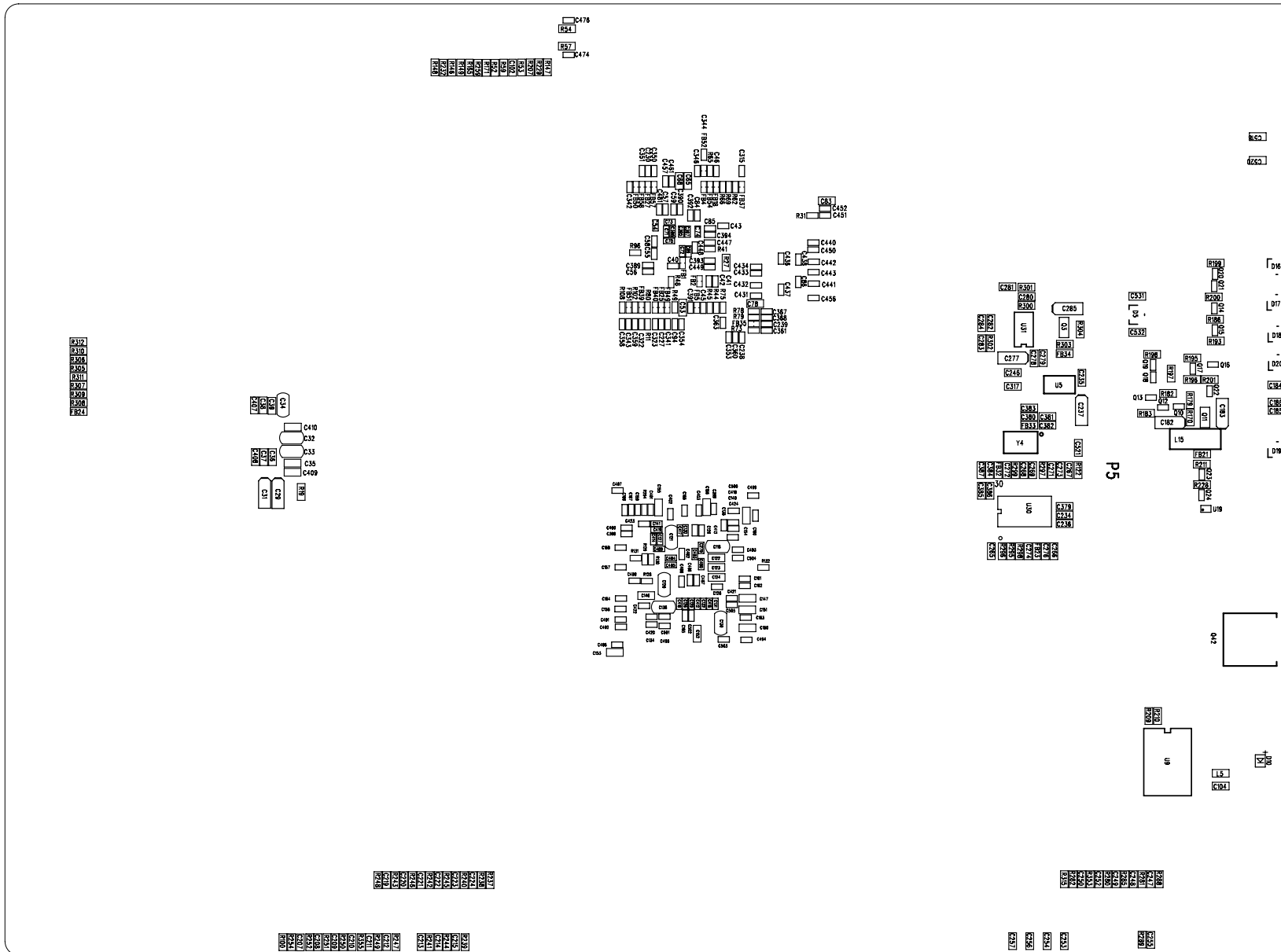
# Figure 5 Power Amplifier Module Bottom Position Mark Diagram



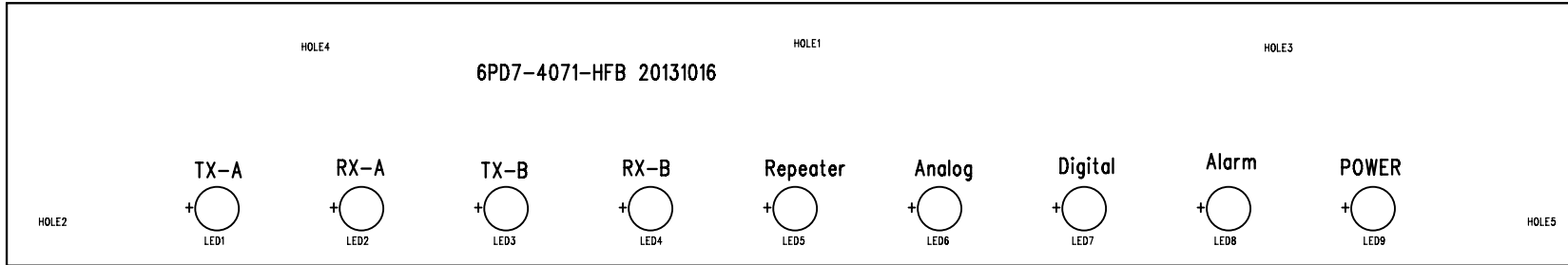




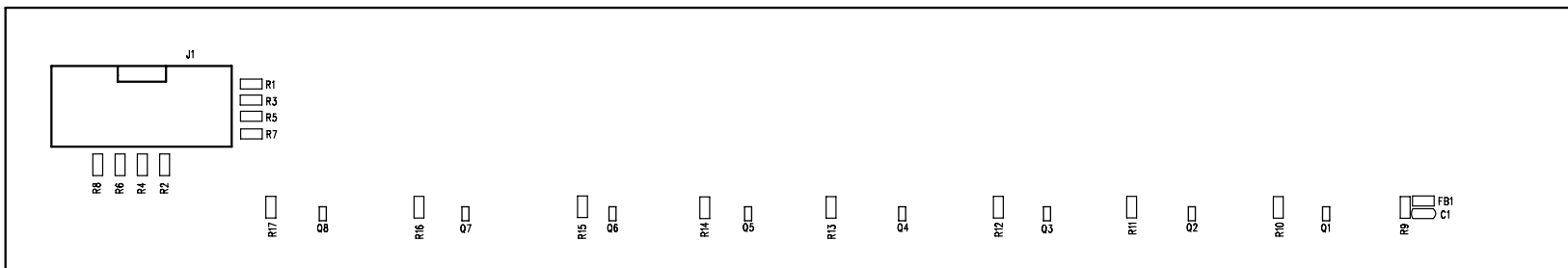
# Figure 7 Baseband Mainboard Bottom Board Position Mark Diagram



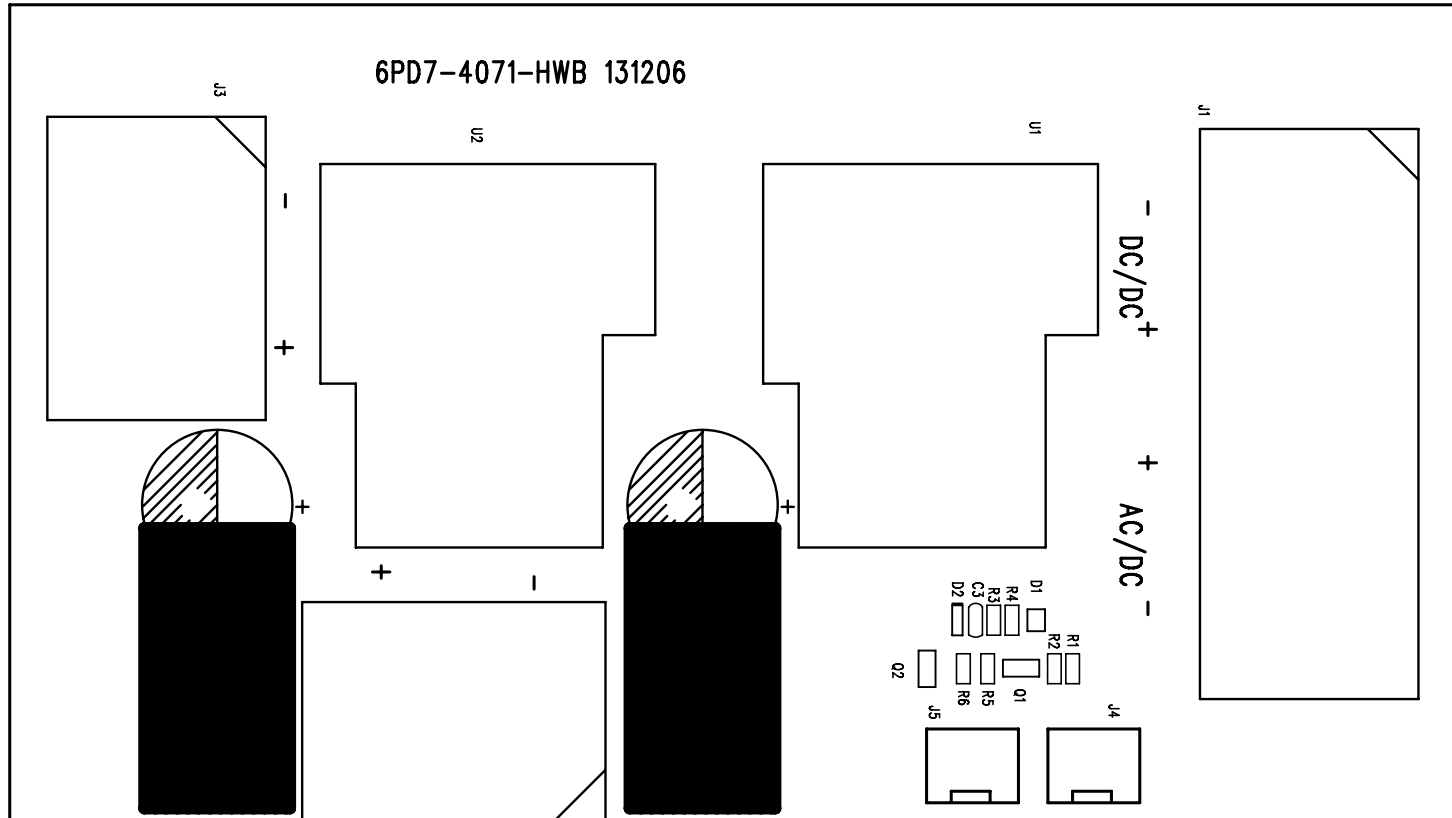
### Figure 8 Front Panel Top Board Position Mark Diagram



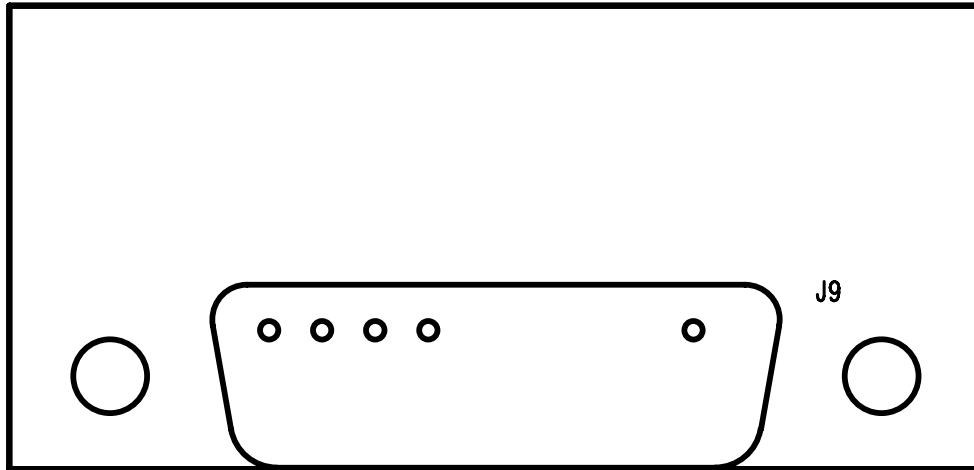
### Figure 9 Front Panel Bottom Board Position Mark Diagram



# Figure 10 Power Board Top Board Position Mark Diagram



**Figure 11 Accessory Board Top Board Position Mark Diagram**



**Figure 12 Accessory Buttom Board Position Mark Diagram**

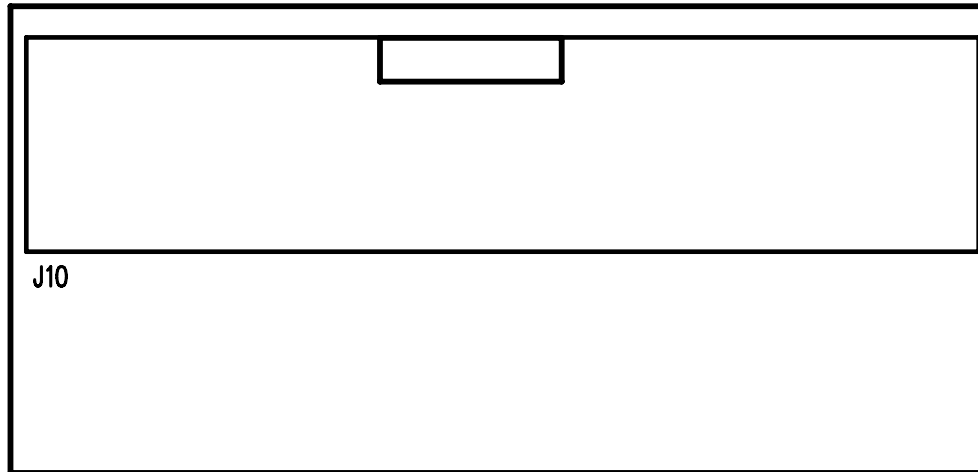
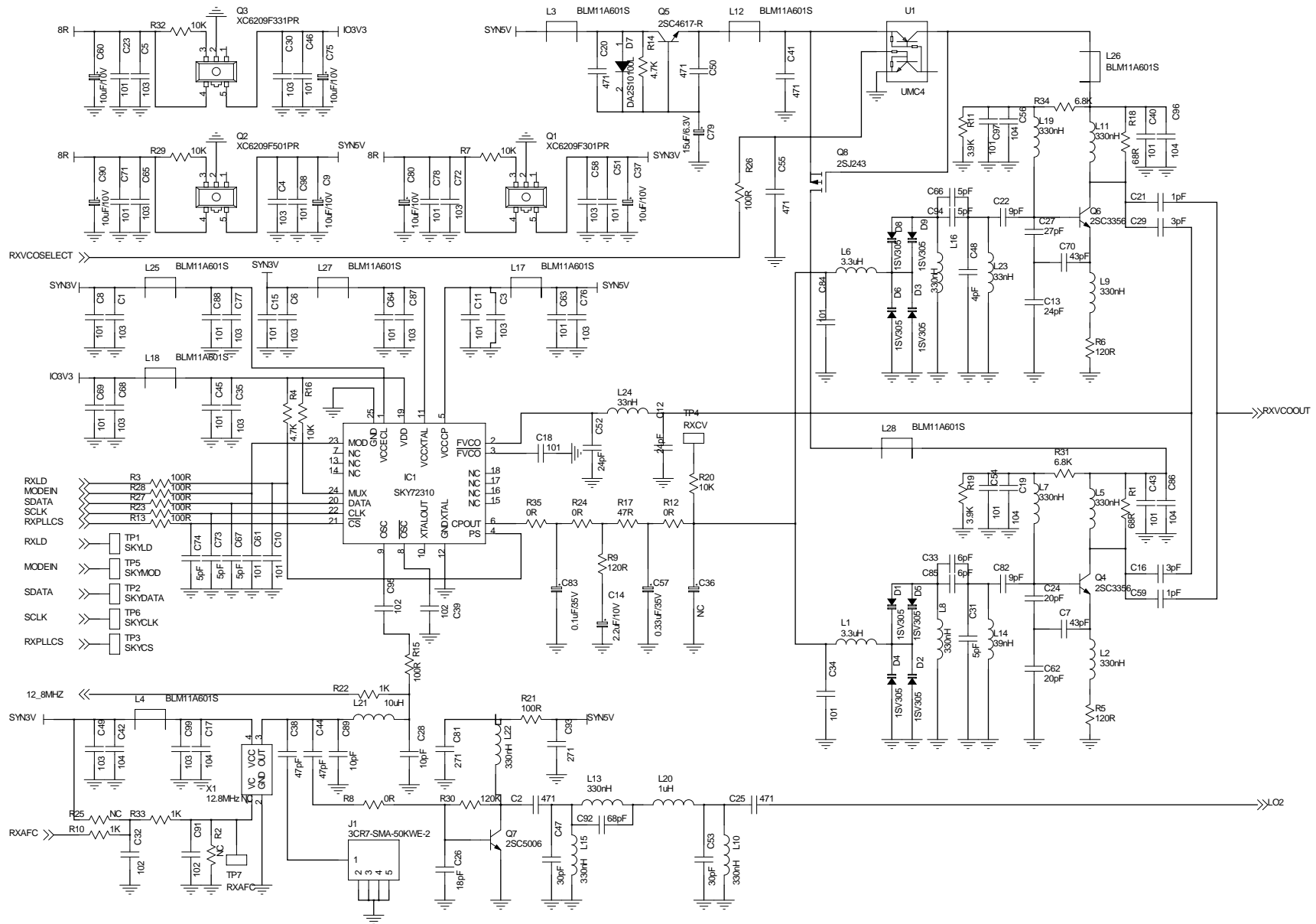
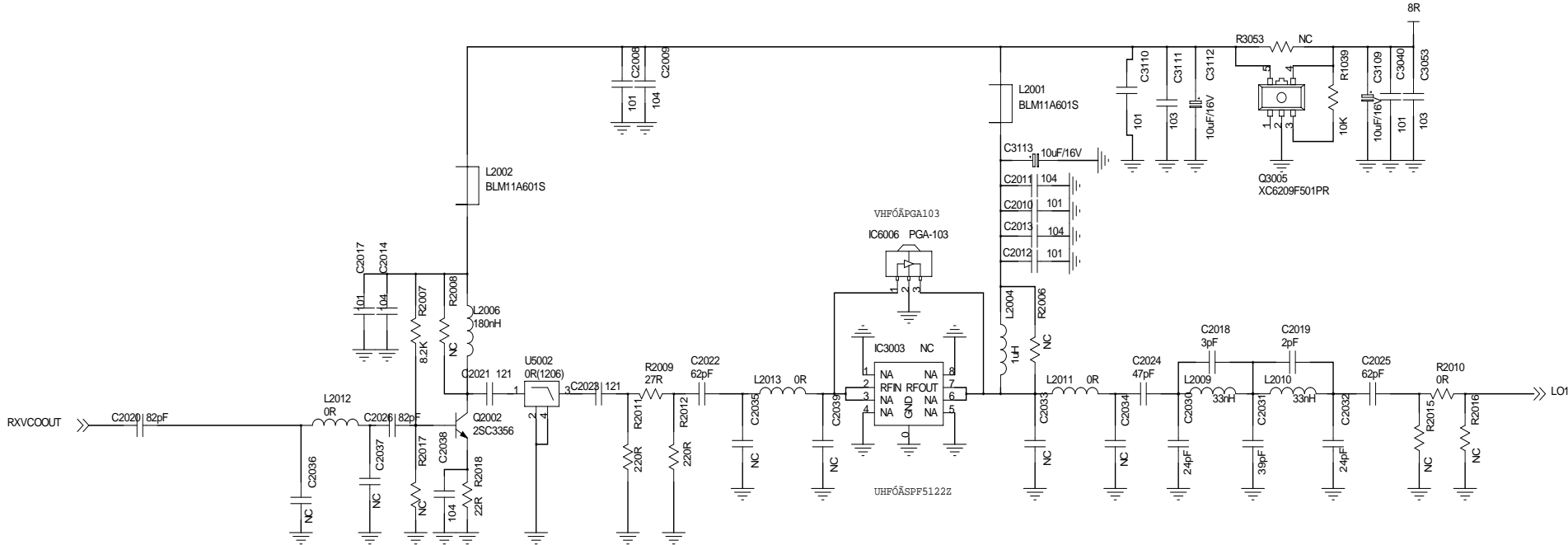
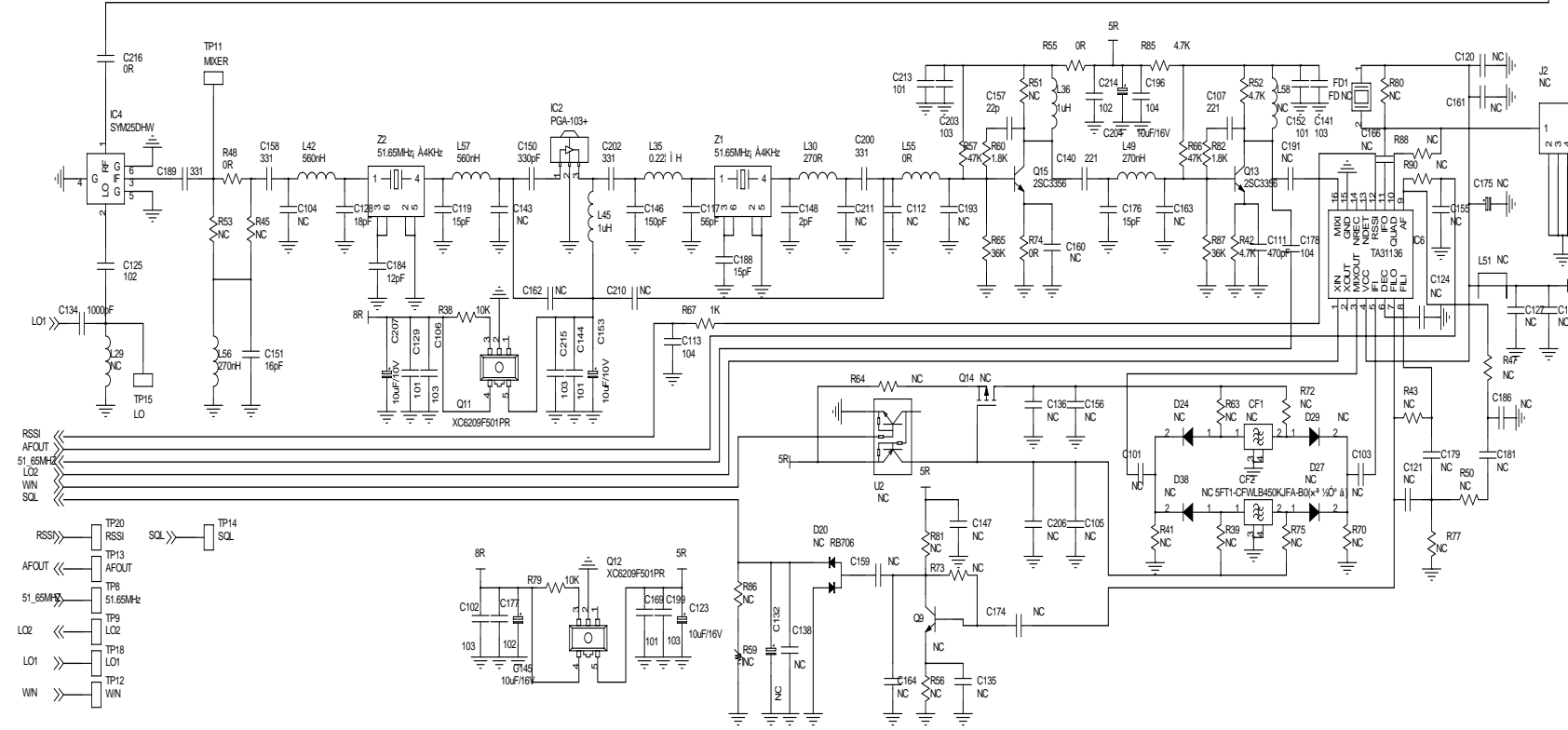
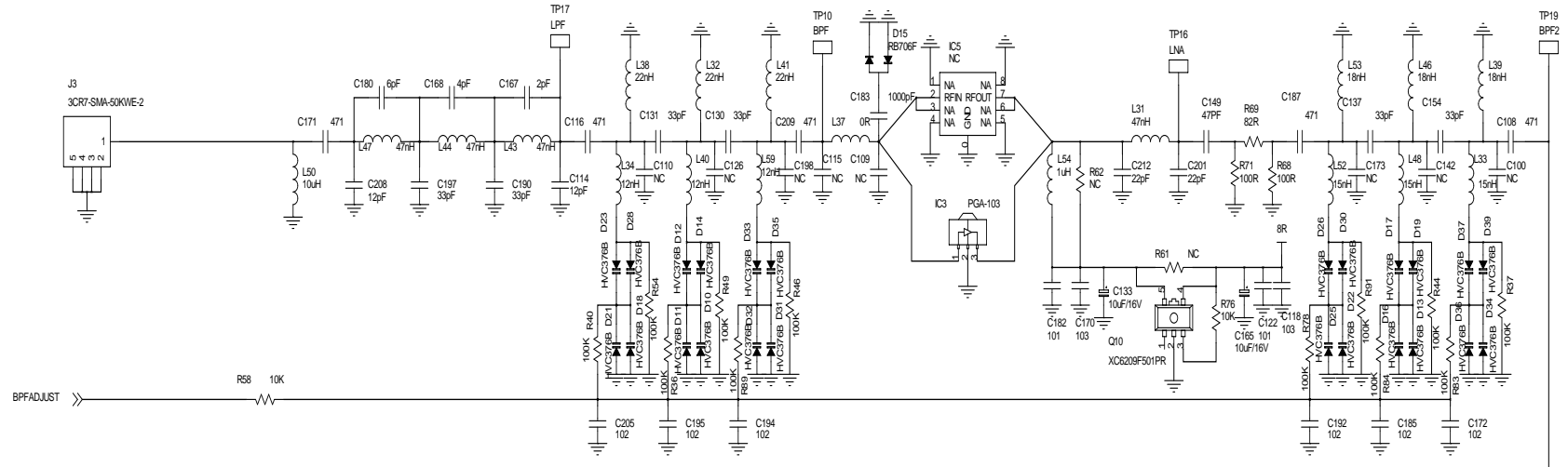


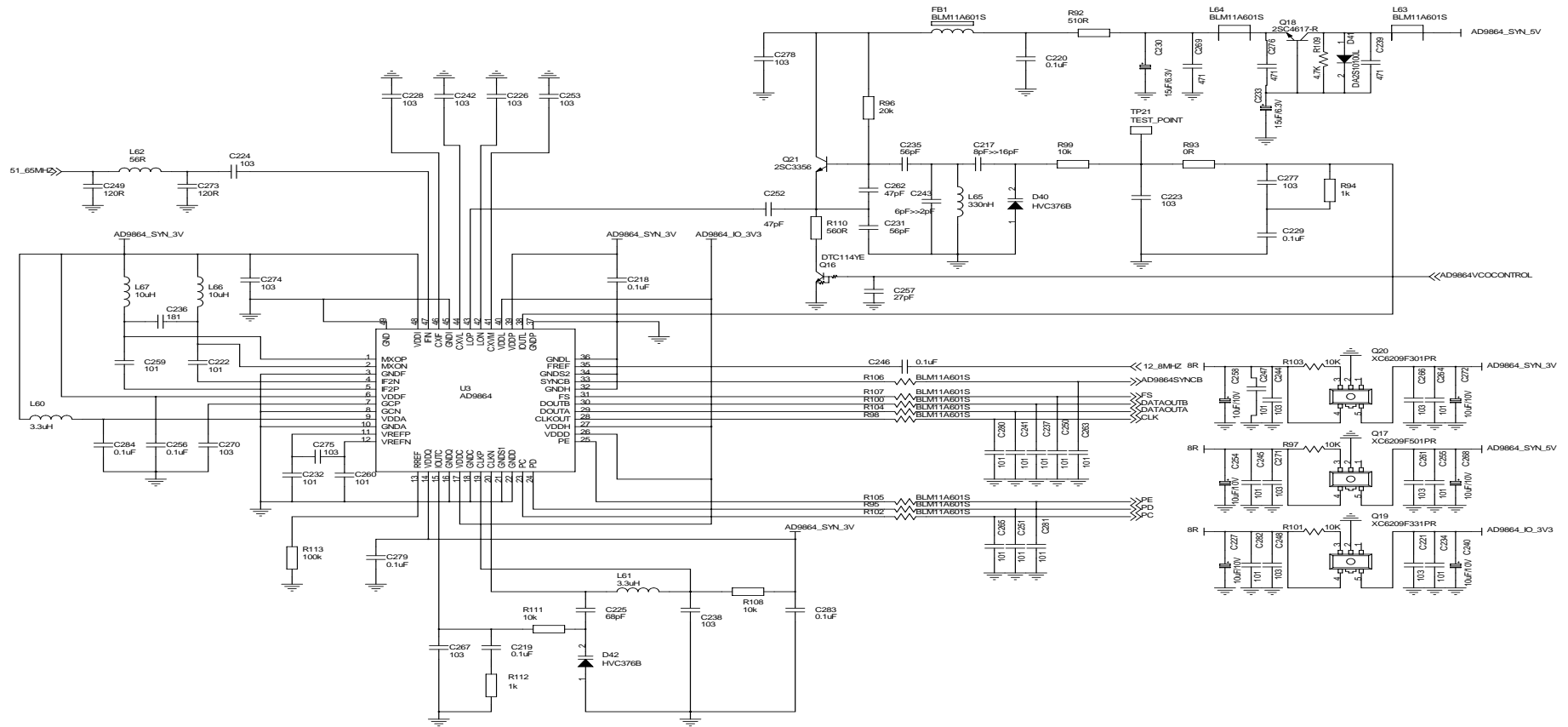
Figure 13 Rx module schematic Diagram

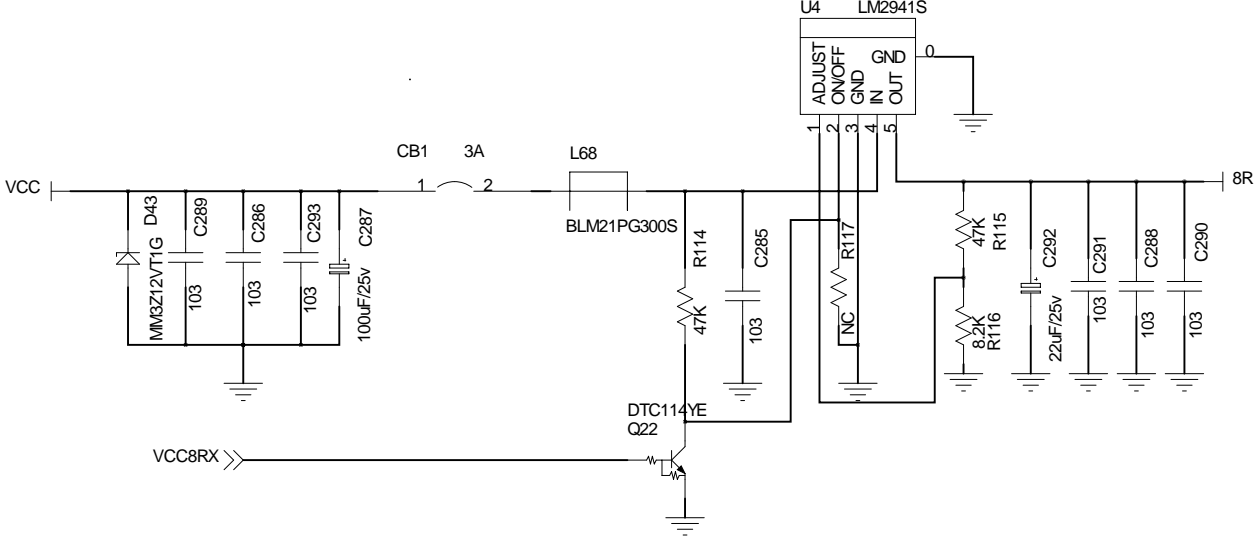


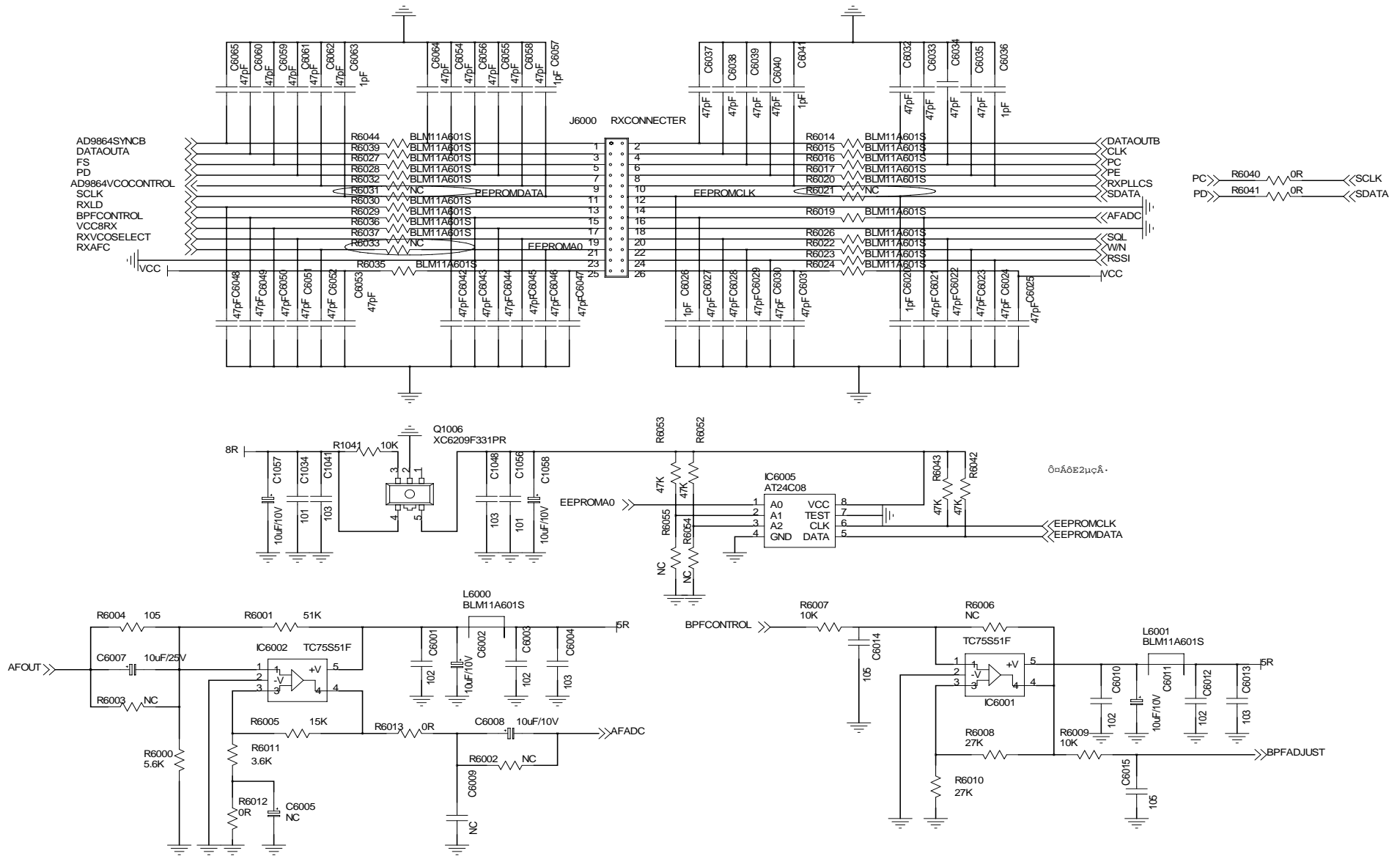












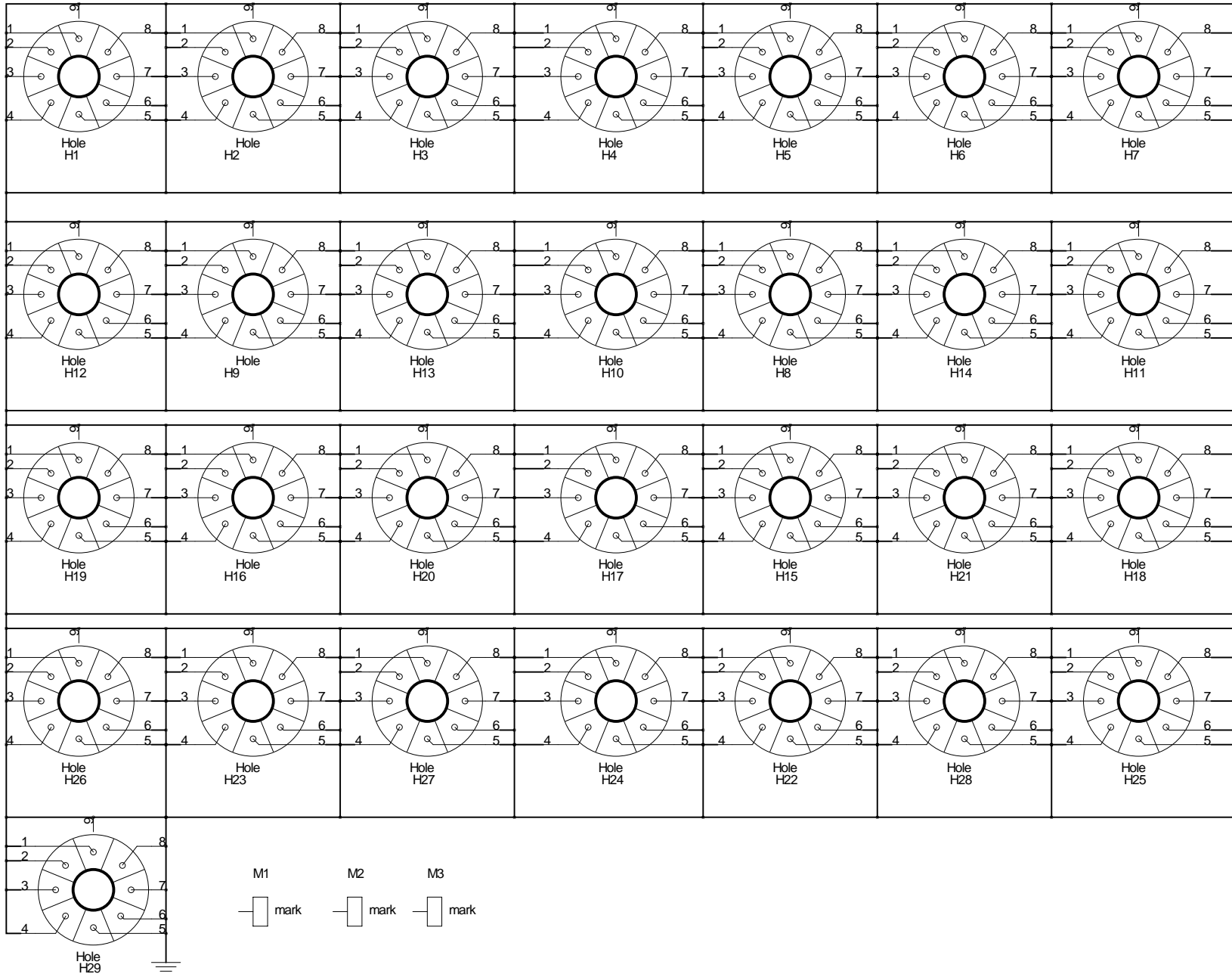
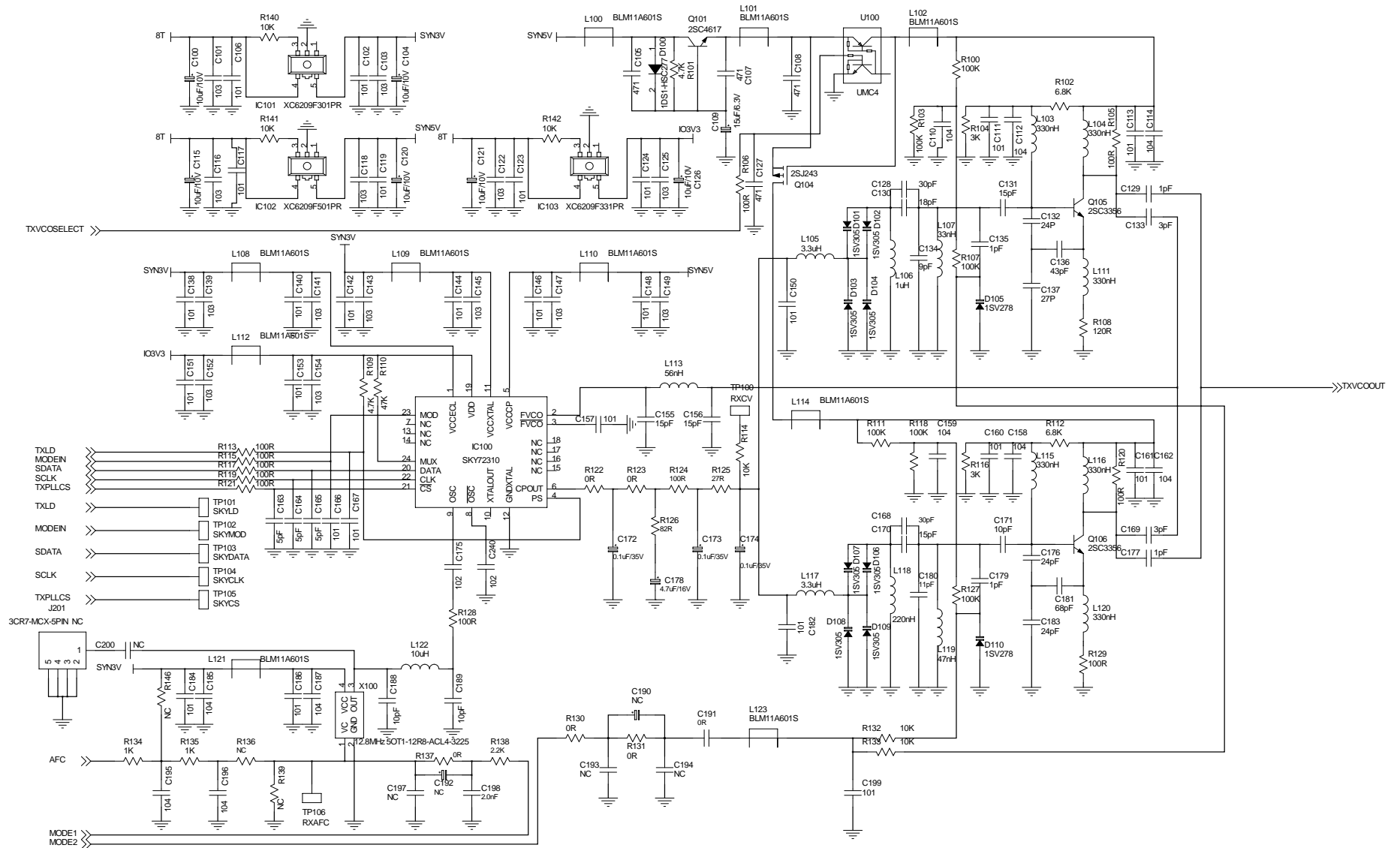
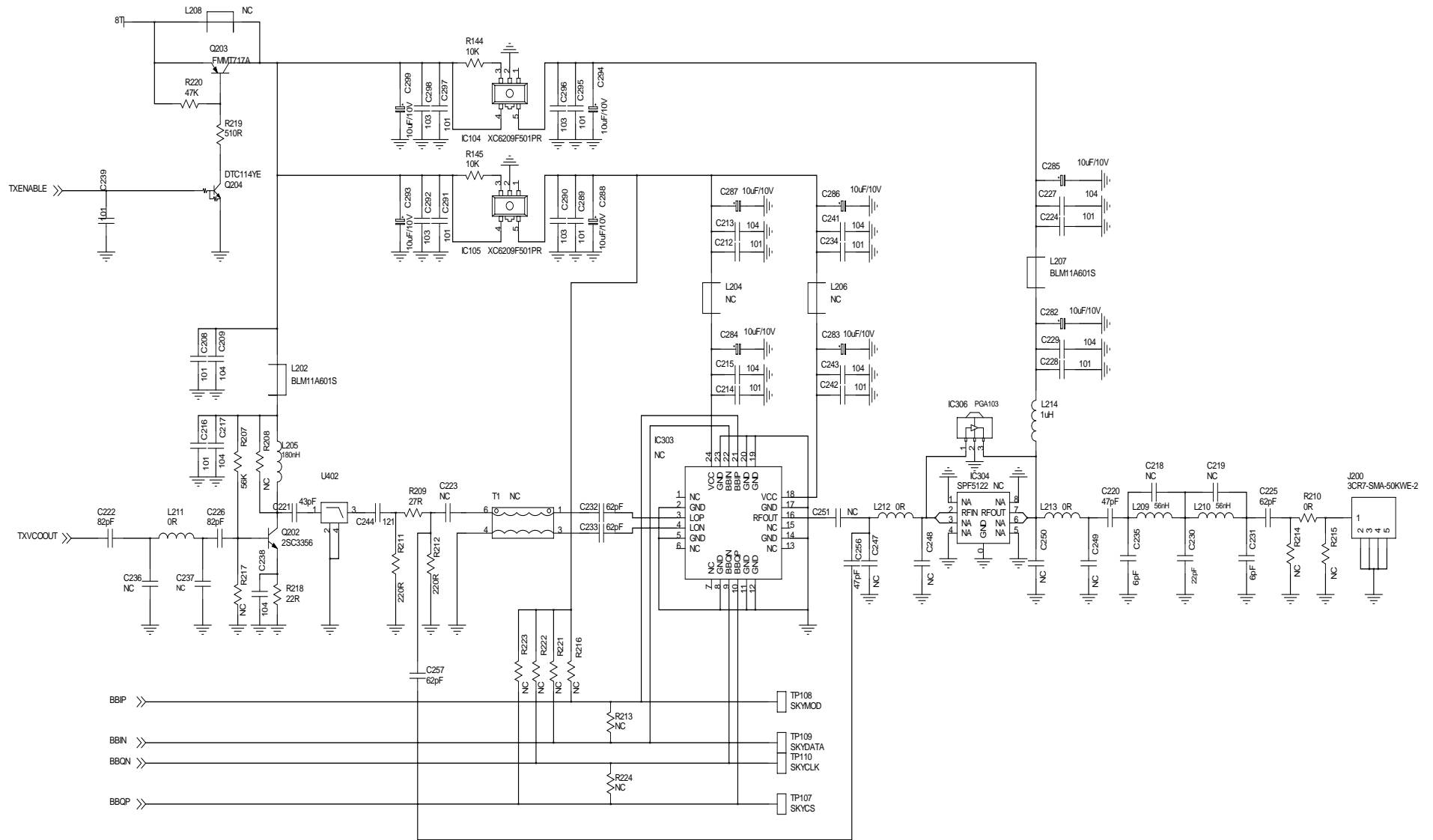
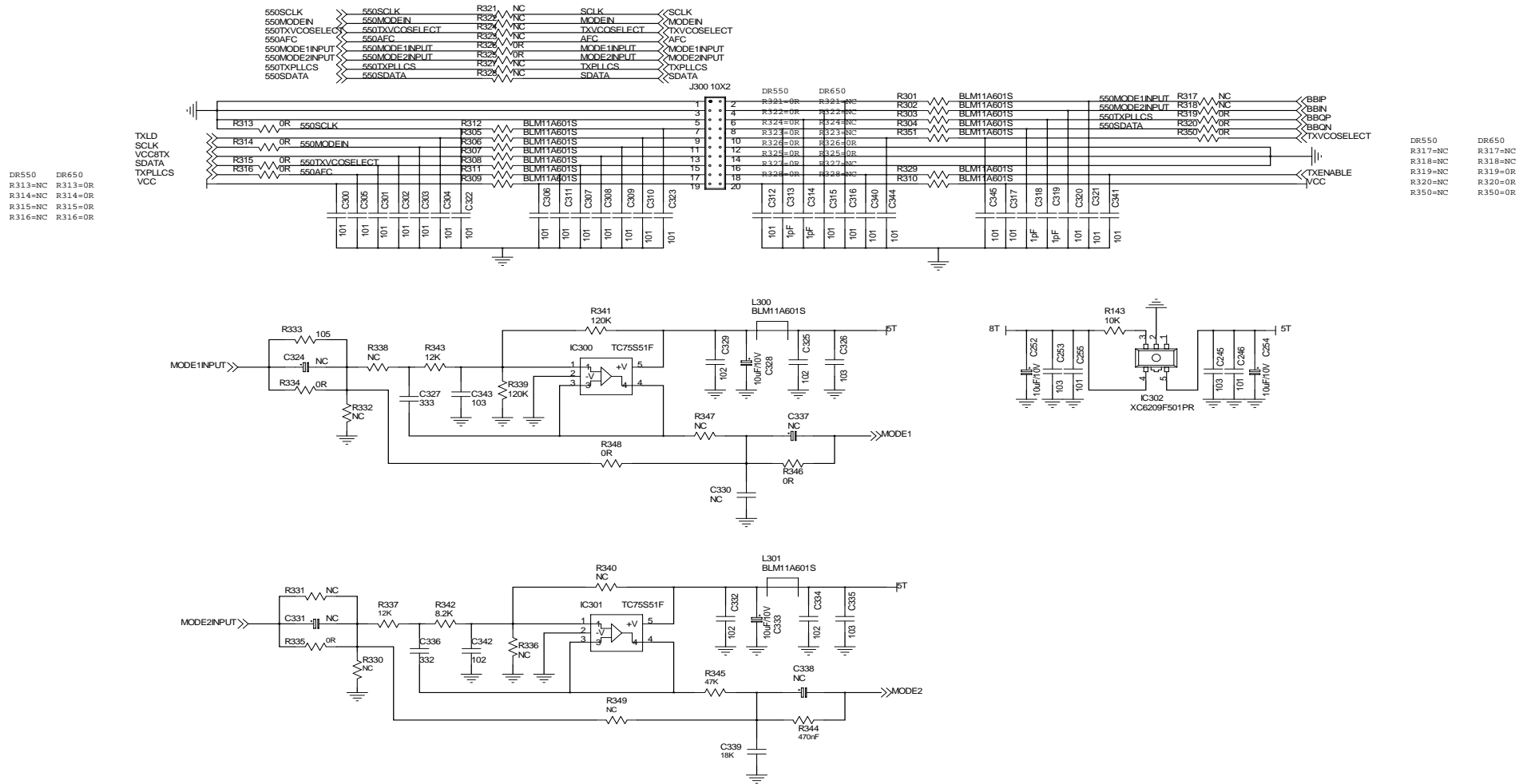
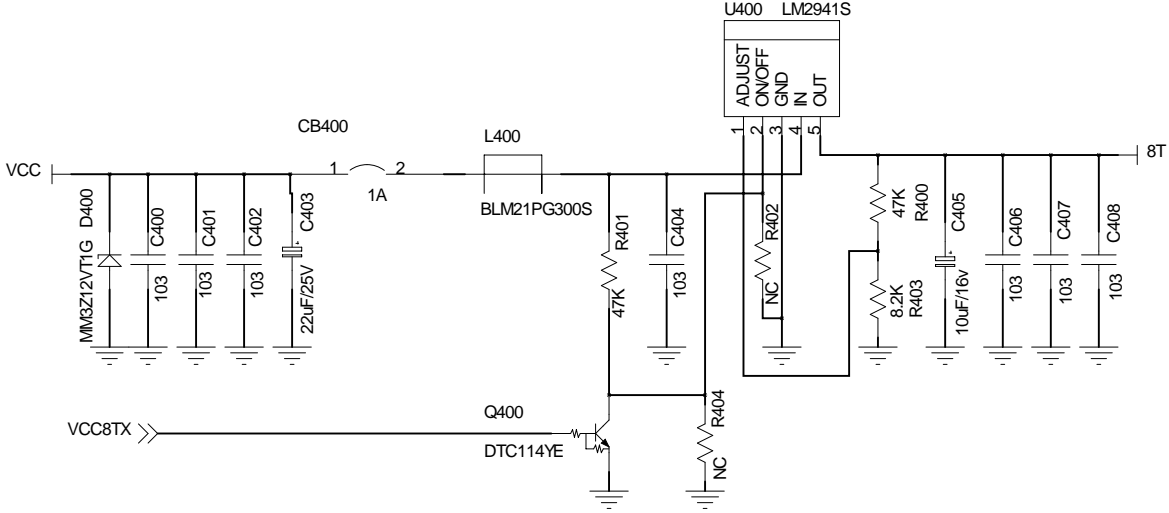


Figure 14 Tx Module Schematic Diagram

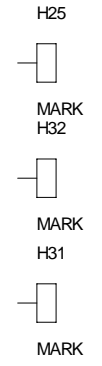
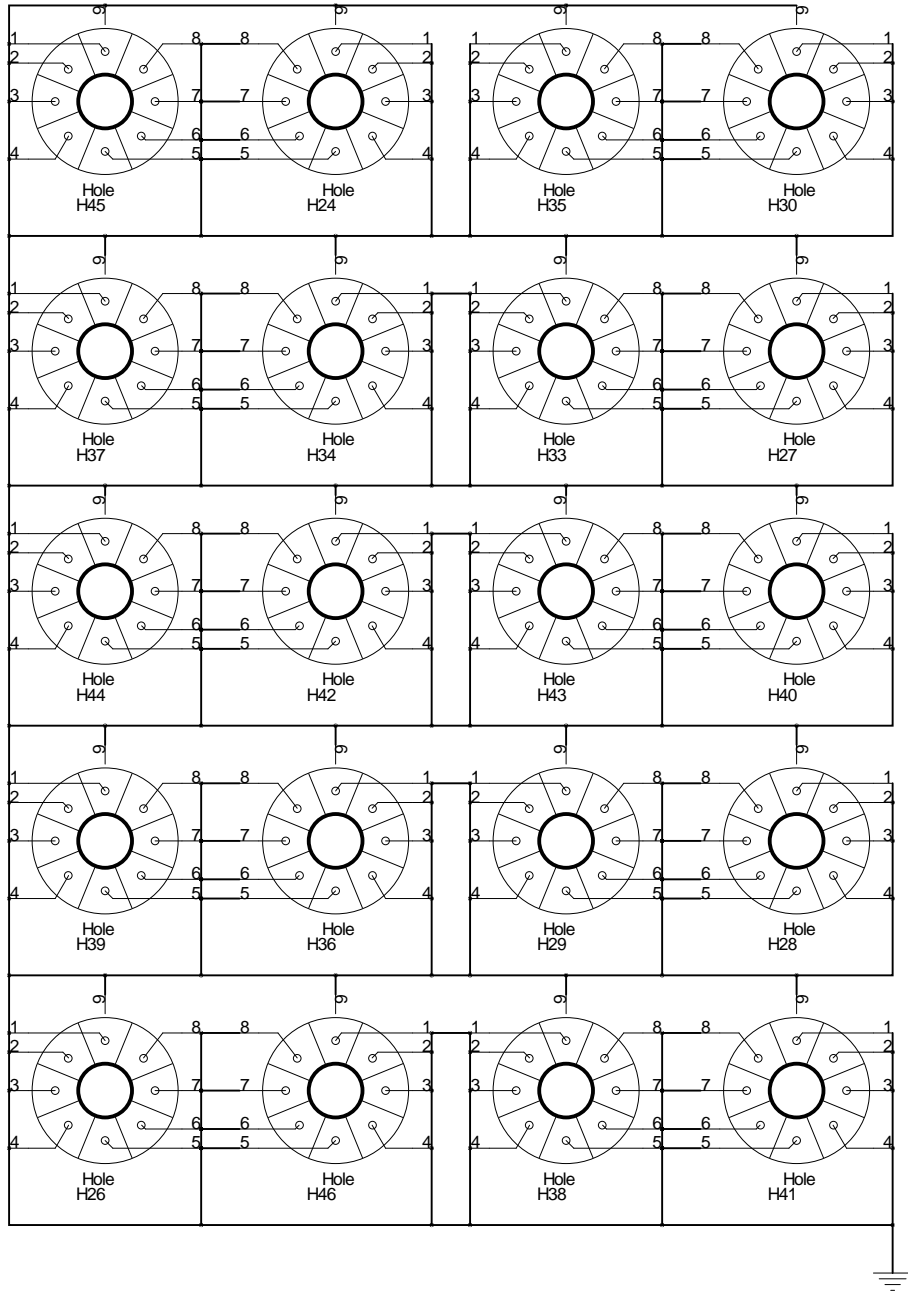




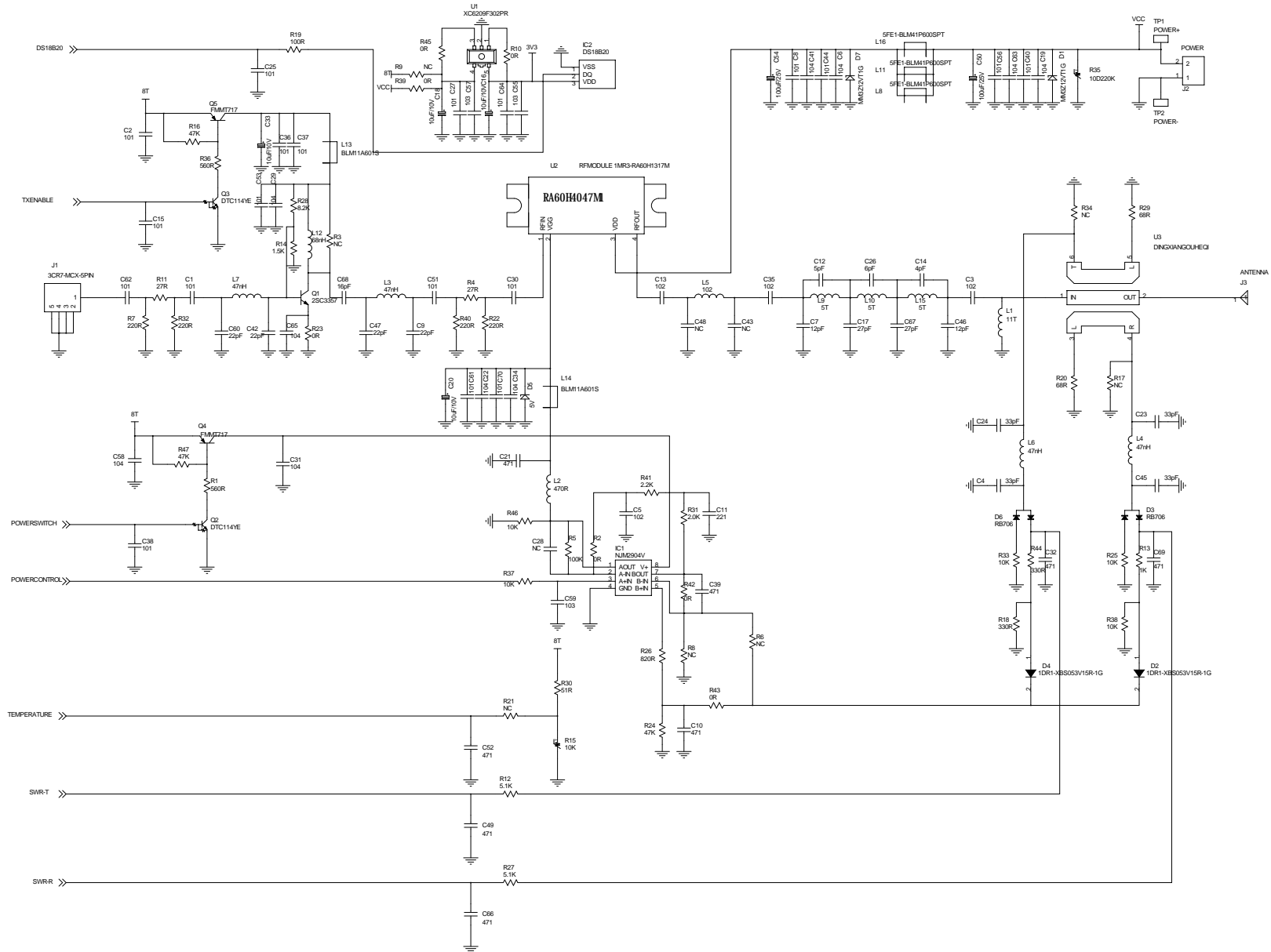


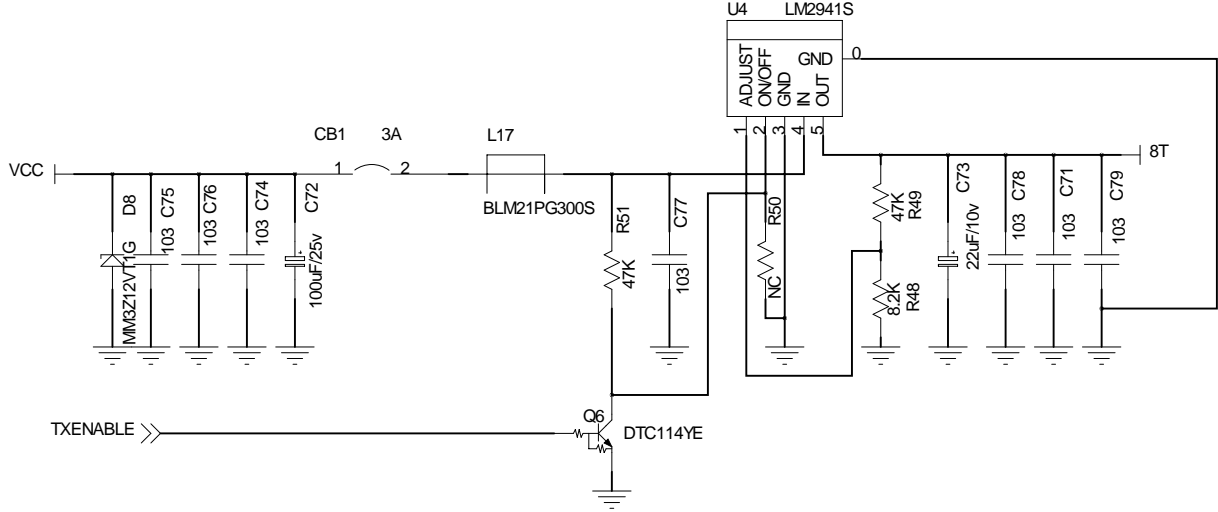






# Figure 15 Power Amplifier Module Schematic Diagram





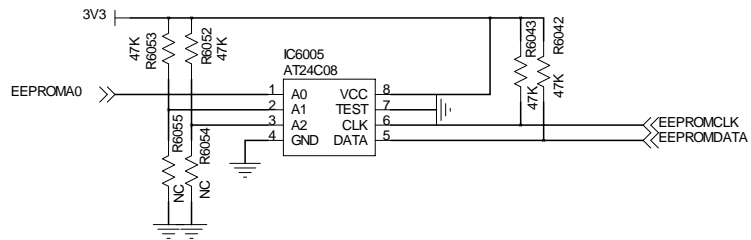
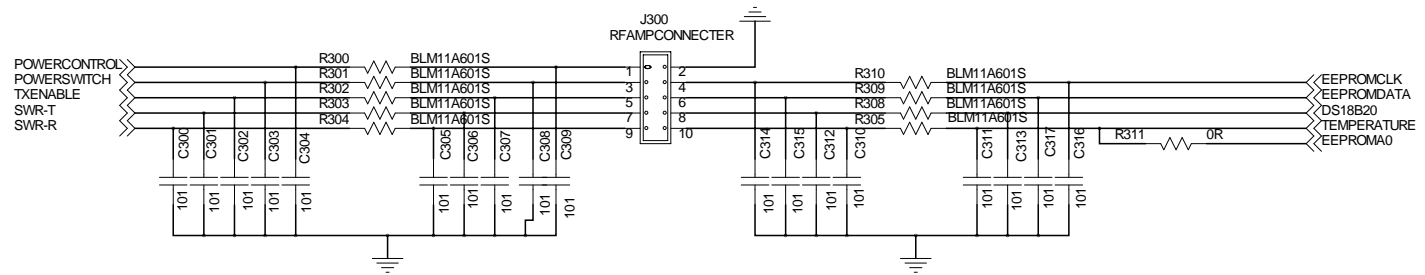
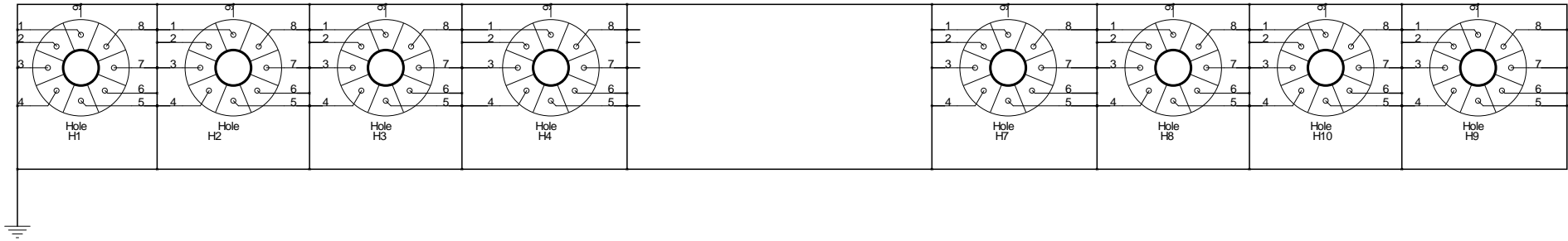
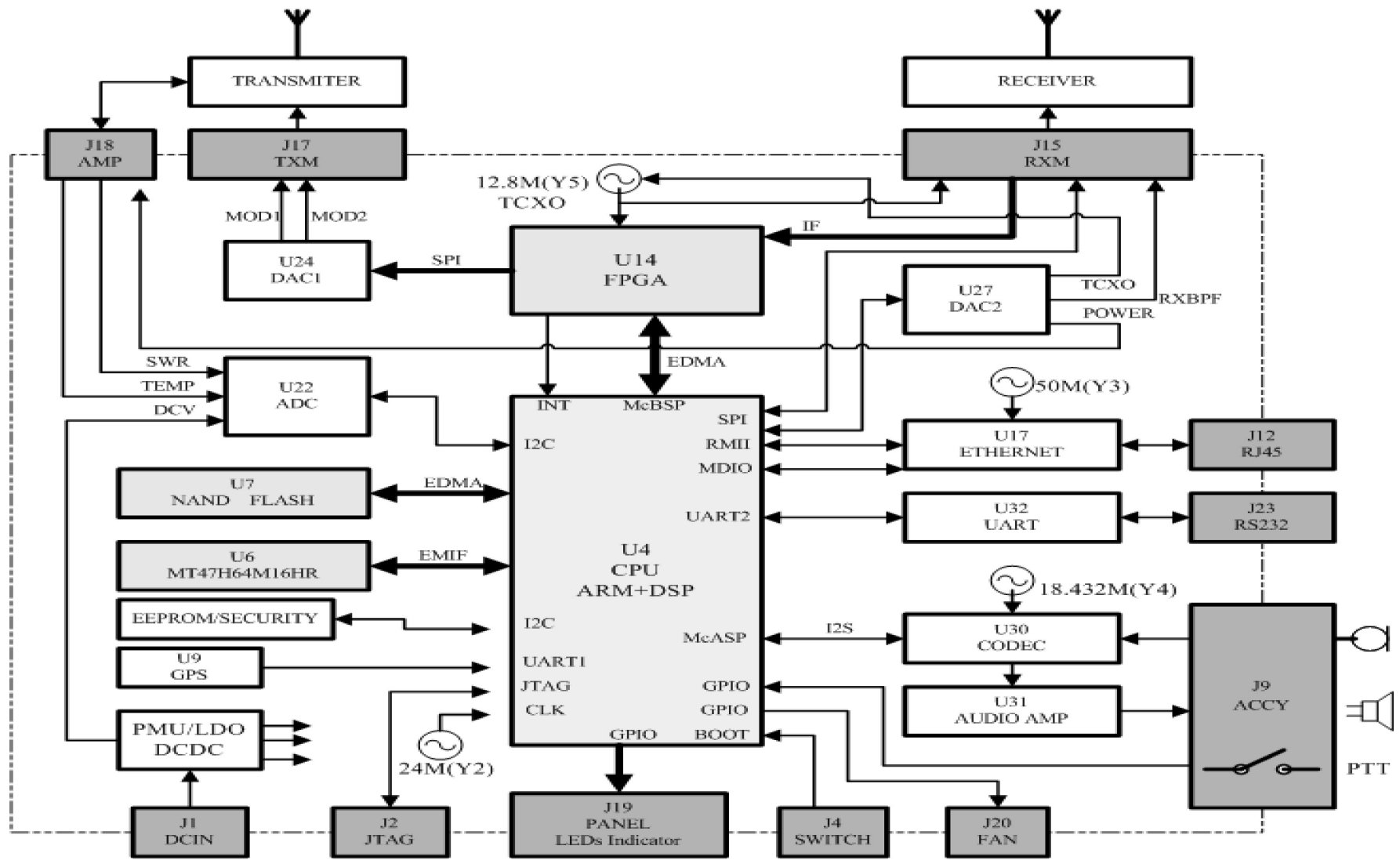
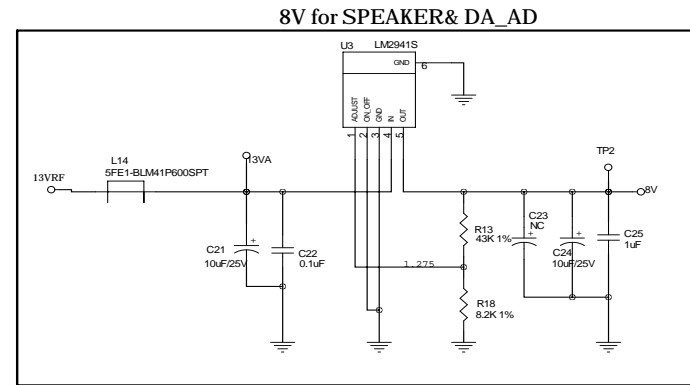
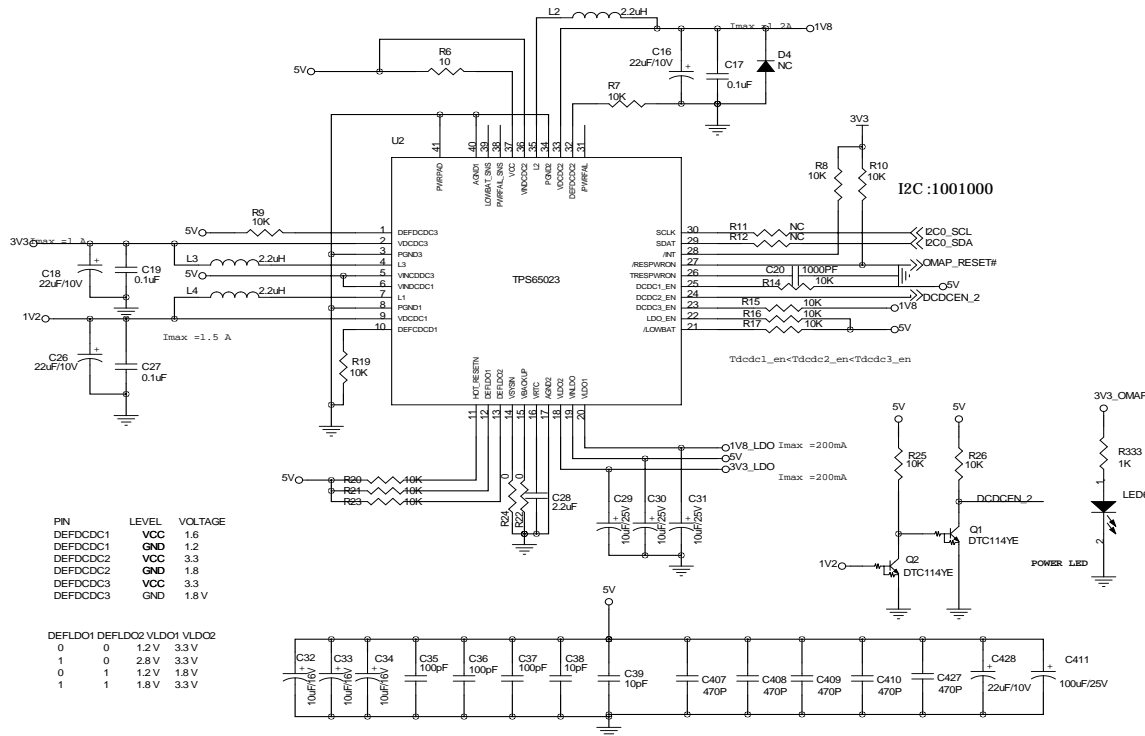
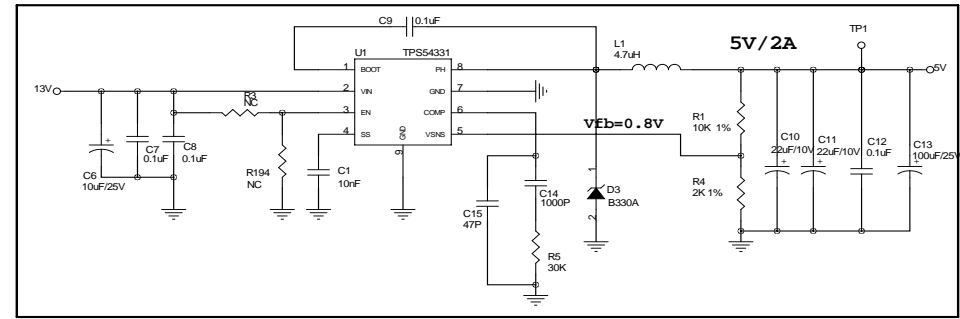
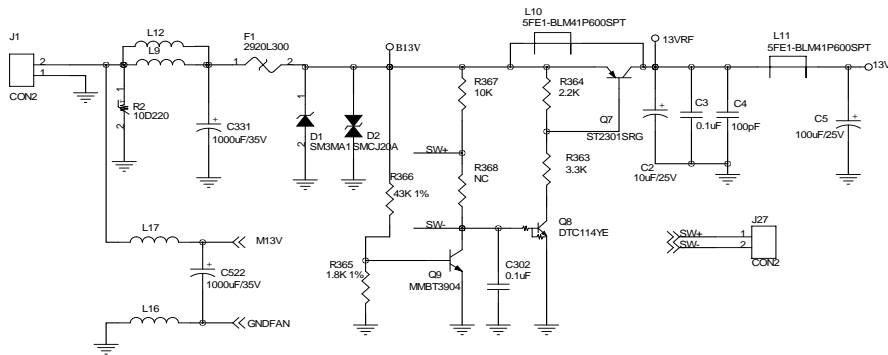
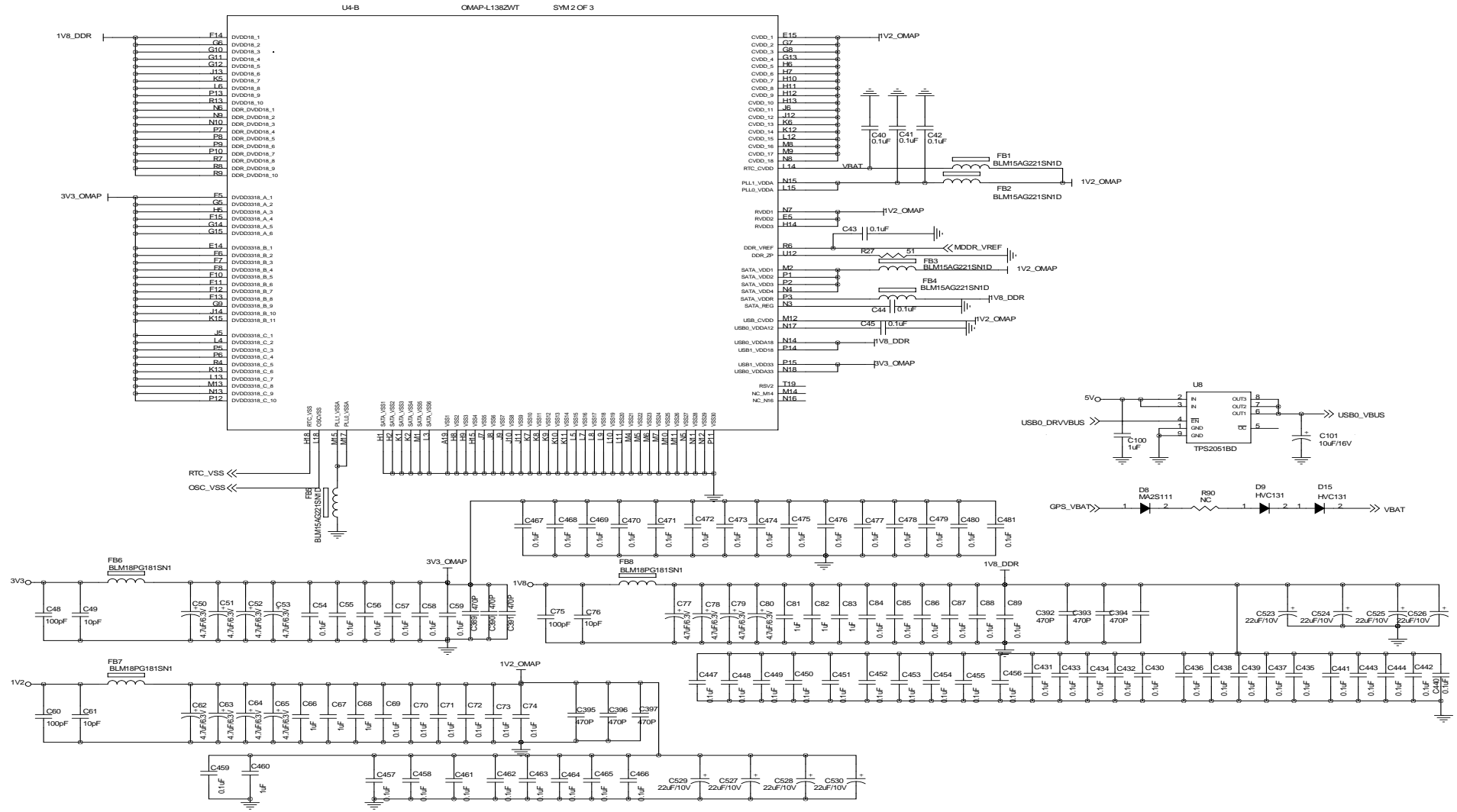


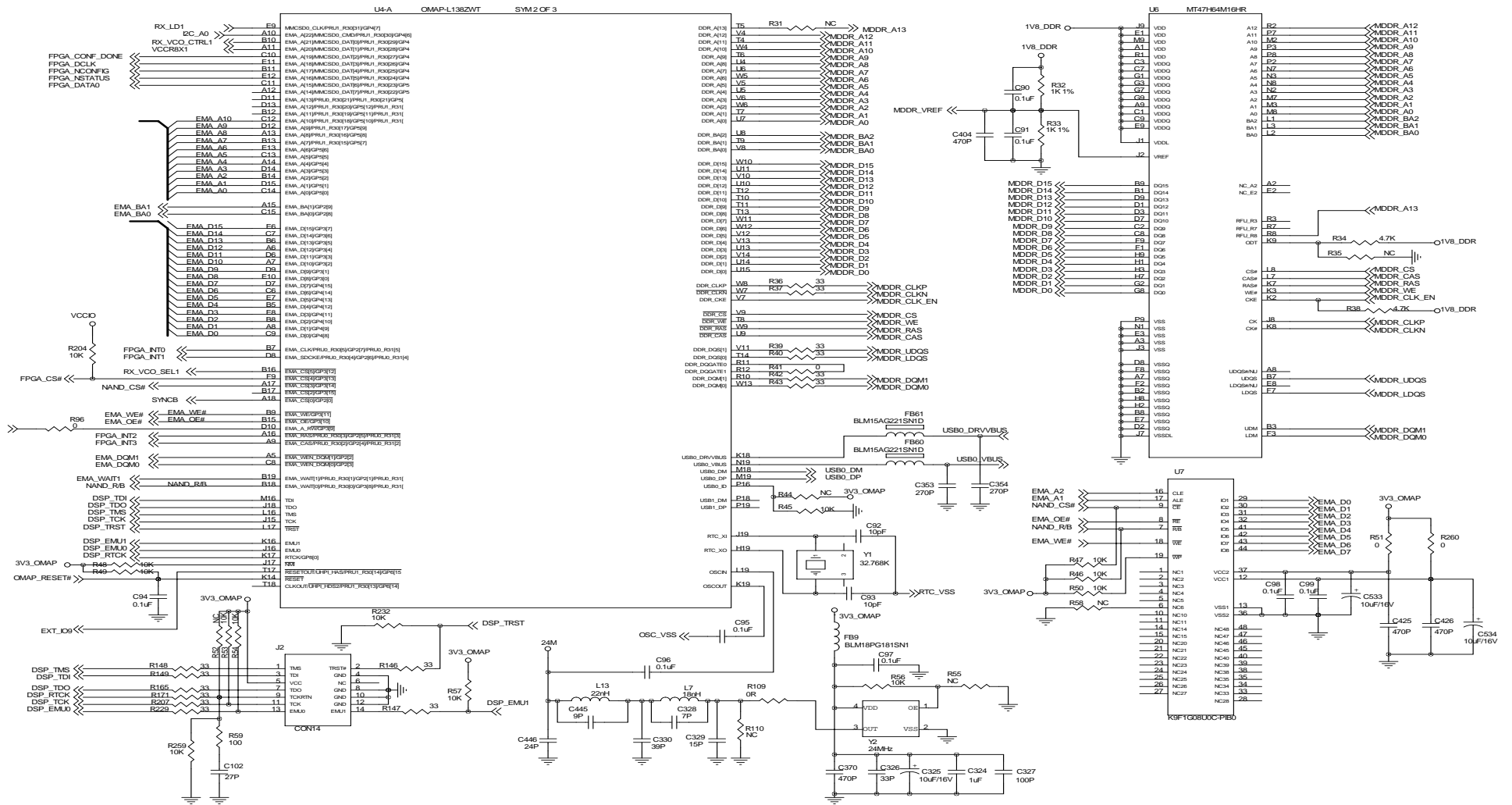
Figure 16 Baseband Mainboard Schematic Diagram



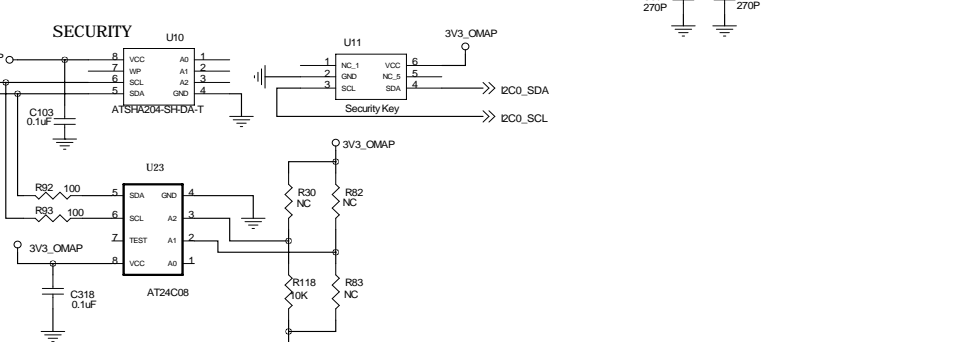
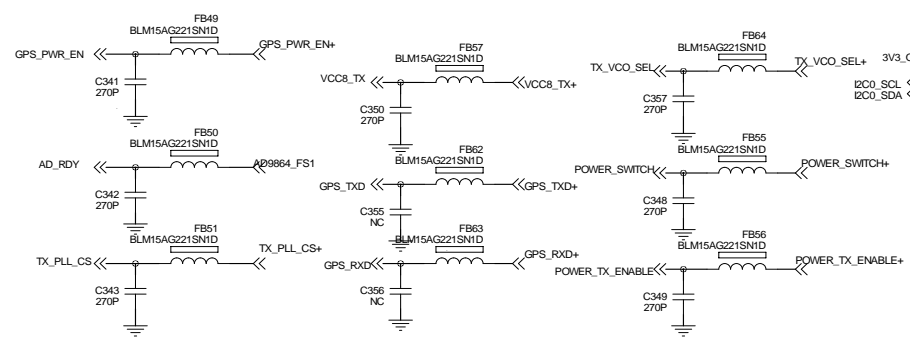
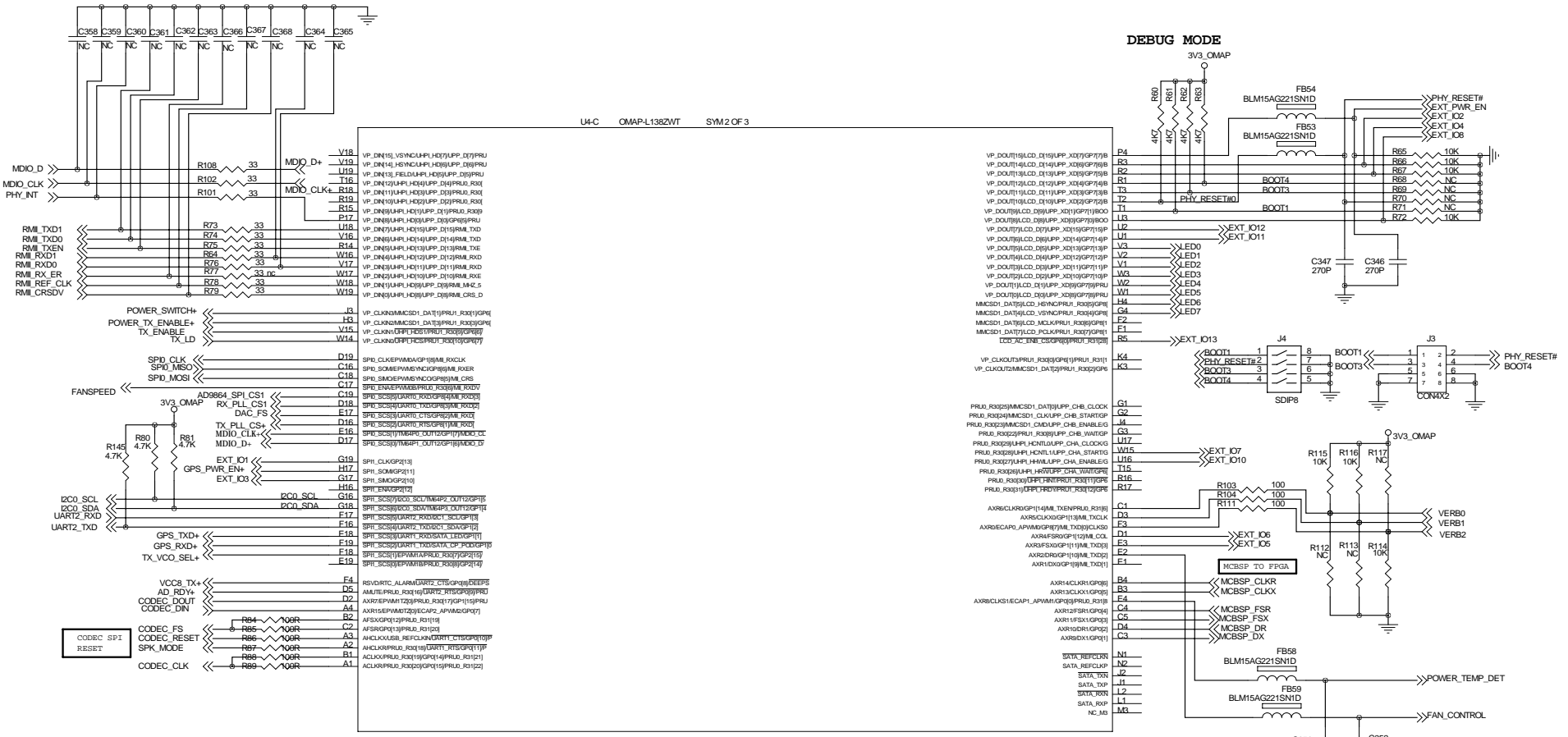


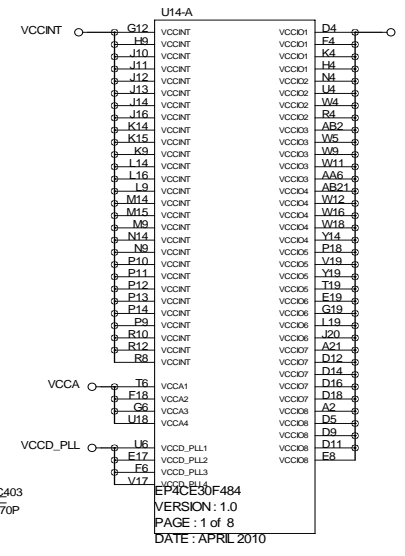
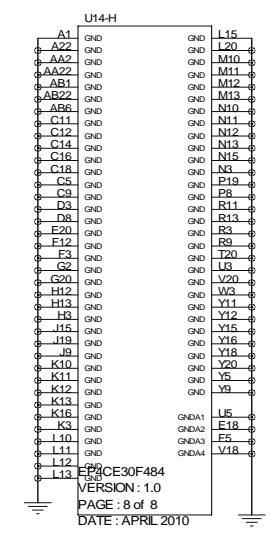
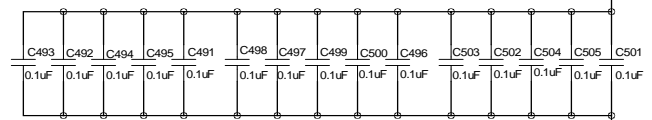
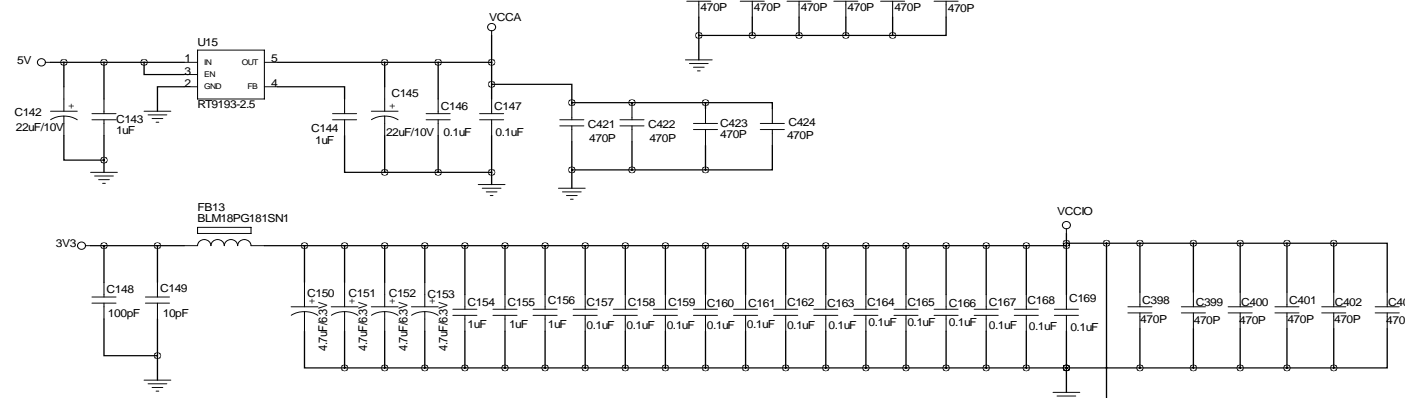
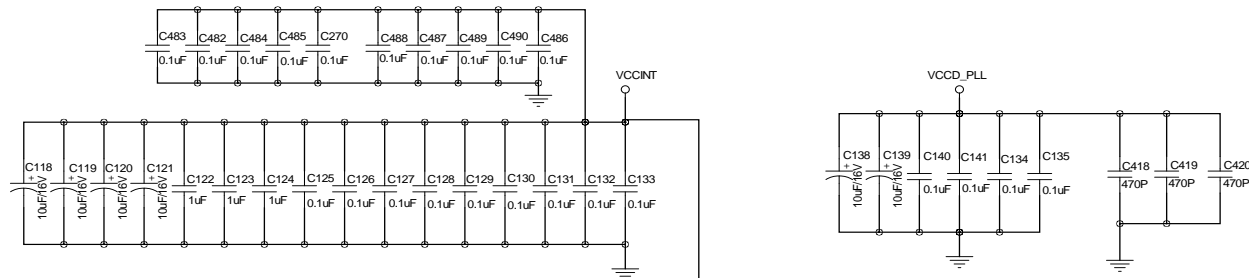
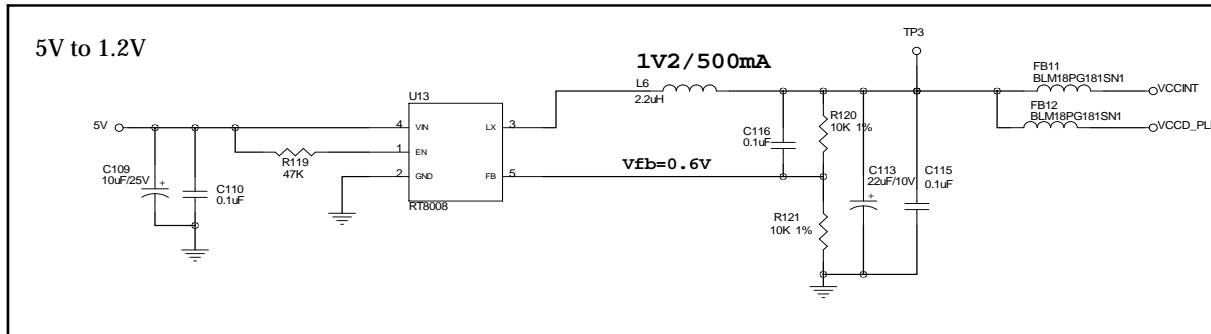
All capacitor not specified is 50V,value tolerance is 20%  
 All resistor not specified value tolerance is 5%

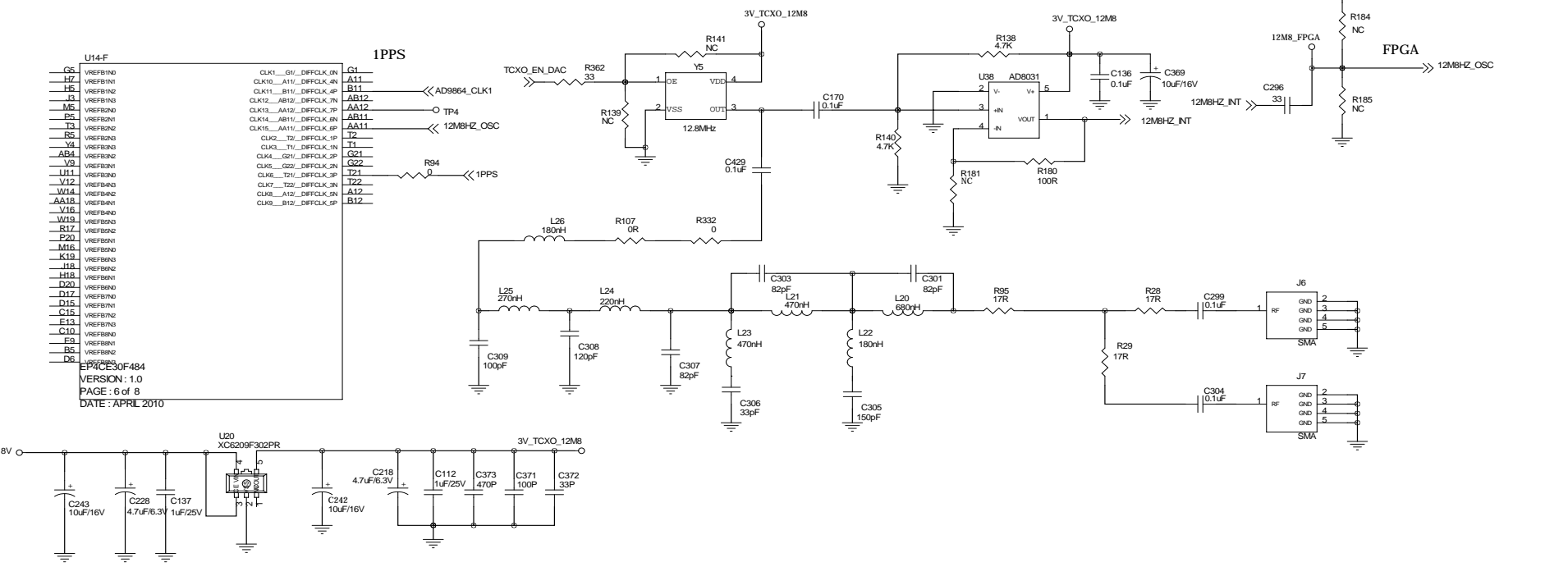
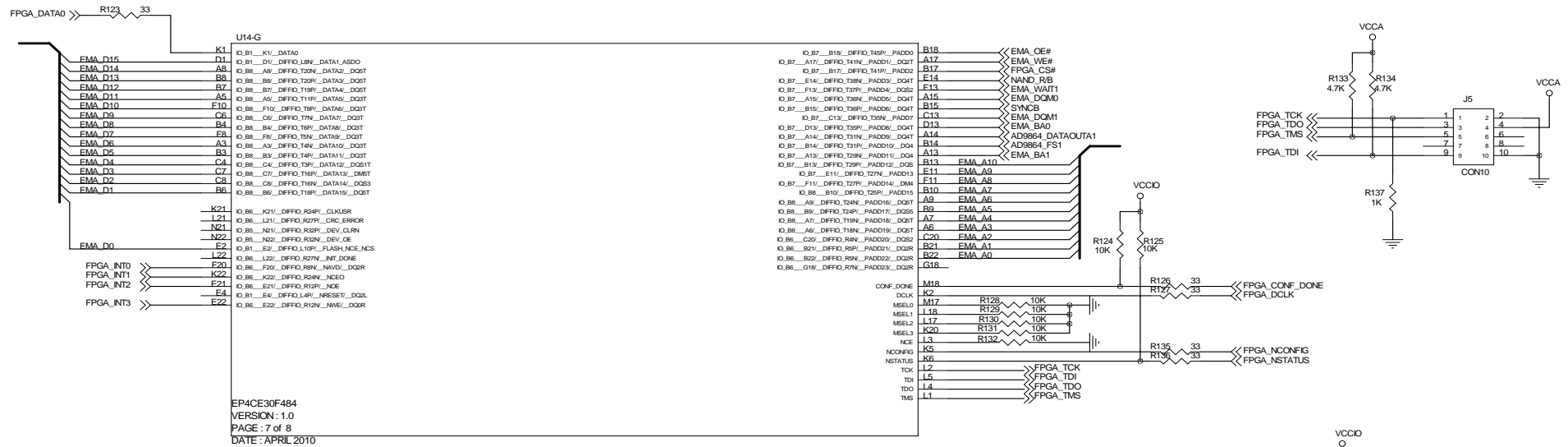






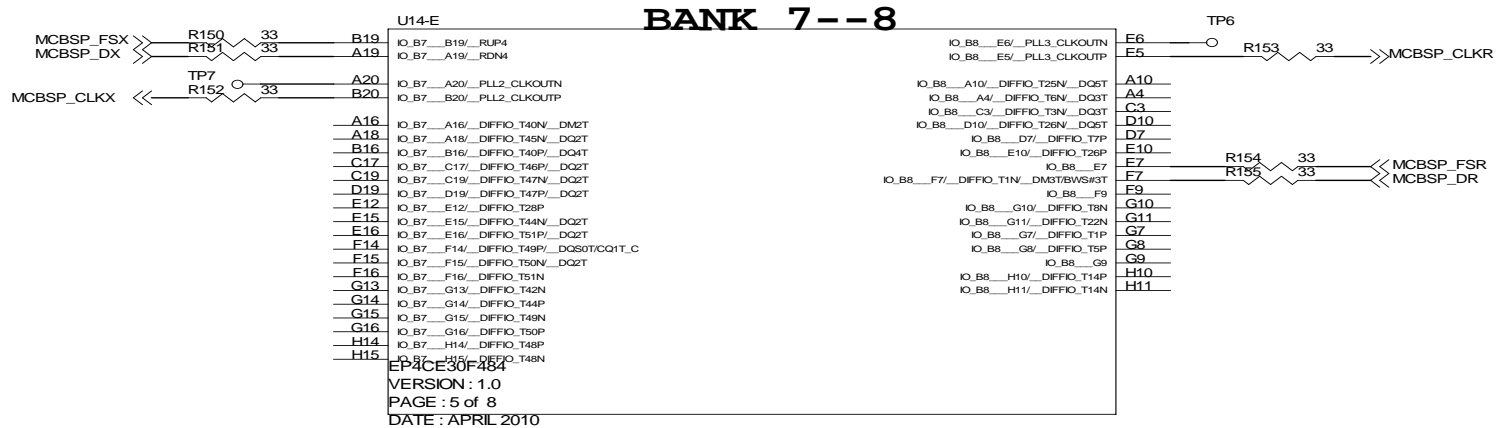
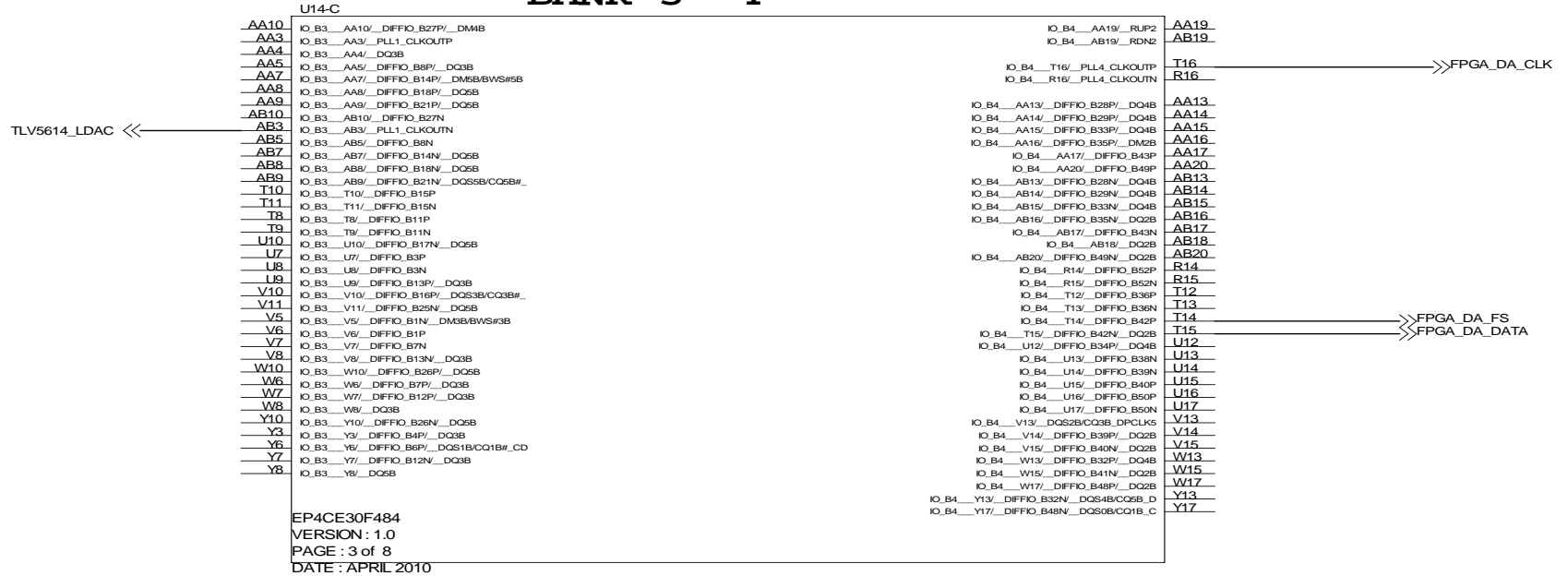






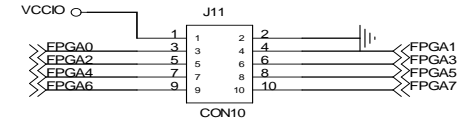
PLL1 used to AD

BANK 3--4



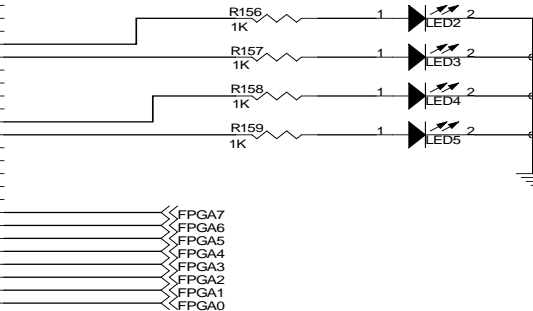
U14-D		<b>BANK 5--6</b>	
T17	IO_B5__T17/_RUP3	IO_B6__C21/_DIFFIO_R6P/_DG2R	C21
T18	IO_B5__T18/_RDN3	IO_B6__C22/_DIFFIO_R6N/_DG2R	C22
AA21	IO_B5__AA21/_DIFFIO_R66P/_DM3R6WS#3R	IO_B6__D21/_DIFFIO_R6P	D21
M19	IO_B5__M19/_DIFFIO_R36P/_DQ1R	IO_B6__D22/_DIFFIO_R6N/_DM6R	D22
M20	IO_B5__M20/_DIFFIO_R30N/_DQ1R	IO_B6__F17/_DIFFIO_R2N/_DG2R	F17
M21	IO_B5__M21/_DIFFIO_R31P/_DQ1R	IO_B6__F19/_DIFFIO_R6P/_DG2R	F19
M22	IO_B5__M22/_DIFFIO_R31N/_DQ1R	IO_B6__F21/_DIFFIO_R18P/_DQ0R	F21
M16	IO_B5__N16/_DIFFIO_R46P	IO_B6__F22/_DIFFIO_R18N/_DQ0R	F22
N17	IO_B5__N17/_DIFFIO_R33N	IO_B6__G17/_DIFFIO_R2P	G17
N18	IO_B5__N18/_DIFFIO_R33P/_DQS1RCO1R_	IO_B6__H16/_DIFFIO_R16P	H16
N19	IO_B5__N19/_DIFFIO_R36P	IO_B6__H17/_DIFFIO_R7P	H17
N20	IO_B5__N20/_DIFFIO_R36N/_DQ1R	IO_B6__H19/_DIFFIO_R13P/_DQ0R	H19
P15	IO_B5__P15/_DIFFIO_R46N	IO_B6__H20/_DIFFIO_R13N/_DQ0R	H20
P16	IO_B5__P16/_DIFFIO_R46P	IO_B6__H21/_DIFFIO_R22P/_DQ0R	H21
P17	IO_B5__P17	IO_B6__H22/_DIFFIO_R22N/_DQ0R	H22
P21	IO_B5__P21/_DIFFIO_R38P/_DQ1R	IO_B6__J17/_DIFFIO_R10N	J17
P22	IO_B5__P22/_DIFFIO_R38N/_DQ1R	IO_B6__J21/_DIFFIO_R23P/_DM6R	J21
R18	IO_B5__R18/_DIFFIO_R42N	IO_B6__J22/_DIFFIO_R23N/_DQS0RCO1R_D	J22
R19	IO_B5__R19/_DIFFIO_R42P/_DM1R6WS#1R	IO_B6__K17/_DIFFIO_R20N	K17
R20	IO_B5__R20/_DIFFIO_R44N/_DQ3R	IO_B6__K18/_DIFFIO_R20P/_DQ0R	K18
R21	IO_B5__R21/_DIFFIO_R39P/_DQ1R		
R22	IO_B5__R22/_DIFFIO_R39N/_DQ1R		
U19	IO_B5__U19/_DIFFIO_R50P		
U20	IO_B5__U20/_DIFFIO_R50N/_DQ3R		
U21	IO_B5__U21/_DIFFIO_R43P/_DQ3R		
U22	IO_B5__U22/_DIFFIO_R43N/_DQ3R		
V21	IO_B5__V21/_DIFFIO_R45P/_DQ3R		
V22	IO_B5__V22/_DIFFIO_R45N/_DQ3R		
W20	IO_B5__W20/_DQS3RCO3R/_CDPCLK4		
W21	IO_B5__W21/_DIFFIO_R49P/_DQ3R		
W22	IO_B5__W22/_DIFFIO_R49N/_DQ3R		
Y21	IO_B5__Y21/_DIFFIO_R51P		
Y22	IO_B5__Y22/_DIFFIO_R51N/_DQ3R		

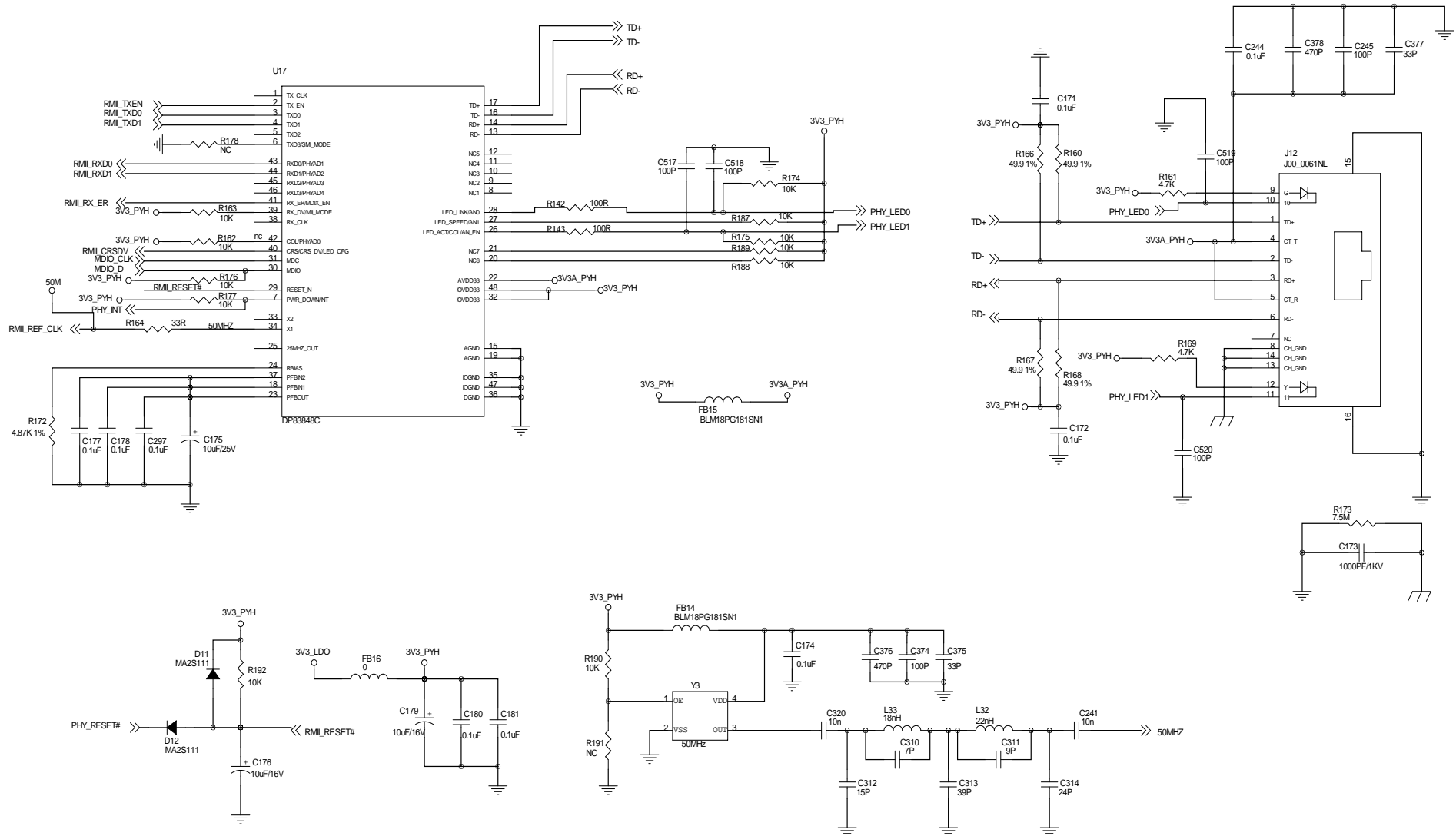
EP4CE30F484  
VERSION : 1.0  
PAGE : 4 of 8  
DATE : APRIL 2010

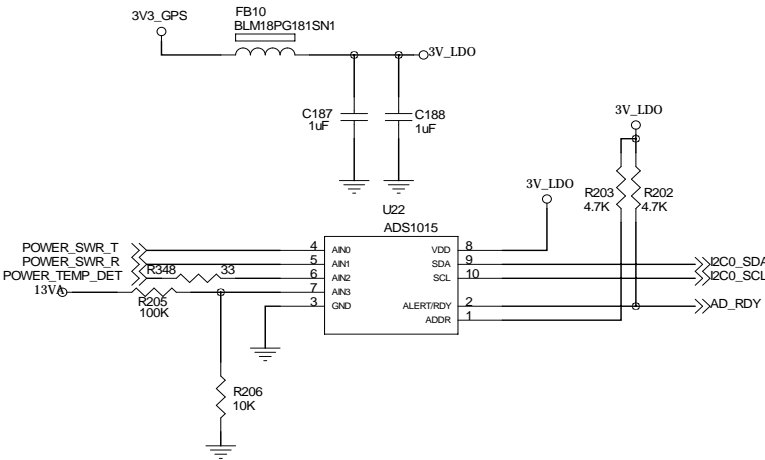
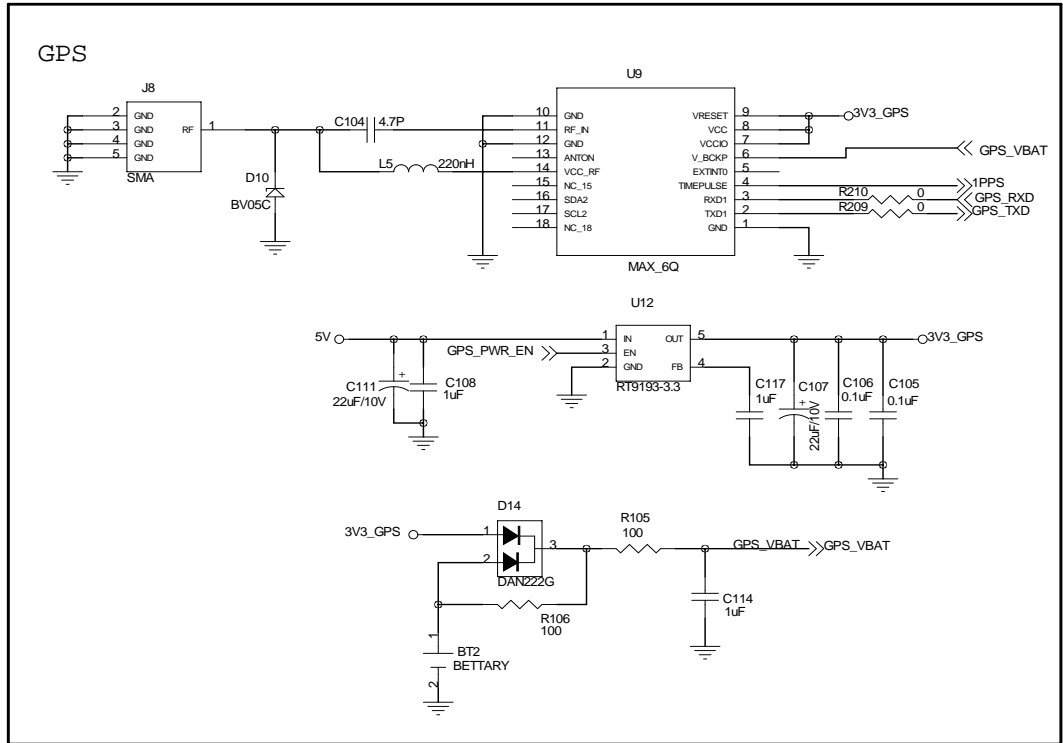


U14-B		<b>BANK 1--2</b>	
B1	IO_B1__B1/_DIFFIO_L2N/_DQ2L	IO_B2__V4/_RUP1	V4
B2	IO_B1__B2/_DIFFIO_L2P/_DQ2L	IO_B2__V3/_RDN1	V3
C1	IO_B1__C1/_DIFFIO_L7N/_DQ2L	IO_B2__AA1/_DIFFIO_L50N/_DQ3L	AA1
C2	IO_B1__C2/_DIFFIO_L7P/_DQS2LCO3L_CDP	IO_B2__L6/_DIFFIO_L26P/_DQ0L	L6
D2	IO_B1__D2/_DIFFIO_L8P/_DQ2L	IO_B2__L7/_DIFFIO_L30N	L7
E1	IO_B1__E1/_DIFFIO_L10N	IO_B2__M1/_DIFFIO_L27N	M1
E3	IO_B1__E3/_DIFFIO_L4N/_DQ2L	IO_B2__M2/_DIFFIO_L27P/_DQ0L	M2
F1	IO_B1__F1/_DIFFIO_L12N/_DQ0L	IO_B2__M3/_DIFFIO_L28N/_DQ1L	M3
F2	IO_B1__F2/_DIFFIO_L12P/_DM2L	IO_B2__M4/_DIFFIO_L28P/_DM0L	M4
G3	IO_B1__G3/_DIFFIO_L1N	IO_B2__M6/_DIFFIO_L28N/_DQ0L	M6
G4	IO_B1__G4/_DIFFIO_L1P	IO_B2__M7/_DIFFIO_L41N	M7
H1	IO_B1__H1/_DIFFIO_L23N/_DQ0L	IO_B2__M8/_DIFFIO_L42P	M8
H2	IO_B1__H2/_DIFFIO_L23P/_DQ0L	IO_B2__N1/_DIFFIO_L29N/_DQ1L	N1
H6	IO_B1__H6/_DIFFIO_L8P/_DQ2L	IO_B2__N2/_DIFFIO_L29P/_DQ1L	N2
H8	IO_B1__H8/_DIFFIO_L14P	IO_B2__N5/_DQ1L	N5
J1	IO_B1__J1/_DIFFIO_L24N/_DQ0L	IO_B2__N6/_DIFFIO_L41P/_DQ3L	N6
J2	IO_B1__J2/_DIFFIO_L24P/_DQ0L	IO_B2__N7/_DIFFIO_L49P	N7
J4	IO_B1__J4/_DQS0LCO1L_DPCLK0	IO_B2__N8/_DIFFIO_L42N	N8
J5	IO_B1__J5/_DIFFIO_L18N	IO_B2__P1/_DIFFIO_L32N/_DQ1L	P1
J6	IO_B1__J6/_DIFFIO_L9N/_DQ2L	IO_B2__P2/_DIFFIO_L32P/_DQ1L	P2
J7	IO_B1__J7/_DIFFIO_L21P	IO_B2__P3/_DIFFIO_L34N/_DQ1L	P3
J8	IO_B1__J8/_DIFFIO_L14N	IO_B2__P4/_DIFFIO_L34P/_DQS1CO1L#_D	P4
K7	IO_B1__K7/_DIFFIO_L21N	IO_B2__P6/_DIFFIO_L52P	P6
K8	IO_B1__K8/_DIFFIO_L20N	IO_B2__P7/_DIFFIO_L49N	P7
L8	IO_B1__L8/_DIFFIO_L20P	IO_B2__R1/_DIFFIO_L33N/_DQ1L	R1
		IO_B2__R2/_DIFFIO_L33P/_DQ1L	R2
		IO_B2__R6	R6
		IO_B2__R7/_DIFFIO_L53P	R7
		IO_B2__T4/_DQS3LCO3L#_CDPCLK1	T4
		IO_B2__T5/_DM3R6WS#3R	T5
		IO_B2__T7/_DIFFIO_L53N	T7
		IO_B2__U1/_DIFFIO_L35N/_DQ3L	U1
		IO_B2__U2/_DIFFIO_L35P/_DM1LBWS#1L	U2
		IO_B2__V1/_DIFFIO_L38N/_DQ3L	V1
		IO_B2__V2/_DIFFIO_L38P/_DQ3L	V2
		IO_B2__W1/_DIFFIO_L44N/_DQ3L	W1
		IO_B2__W2/_DIFFIO_L44P/_DQ3L	W2
		IO_B2__Y1/_DIFFIO_L45N/_DQ3L	Y1
		IO_B2__Y2/_DIFFIO_L45P/_DQ3L	Y2

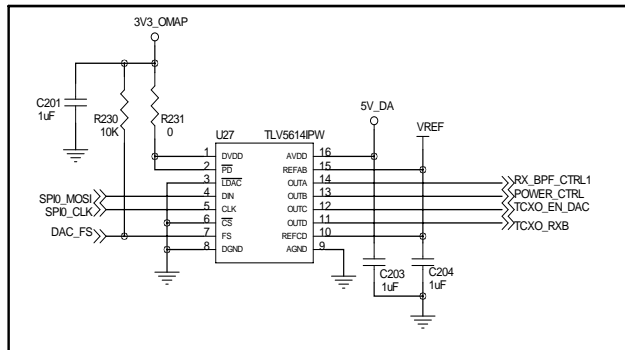
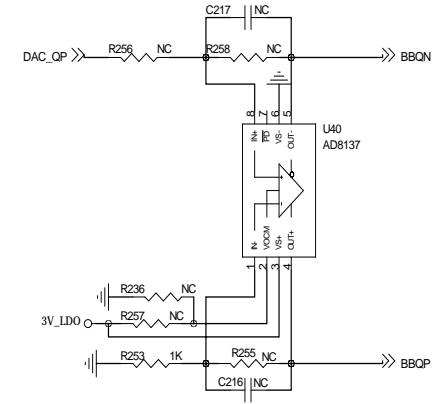
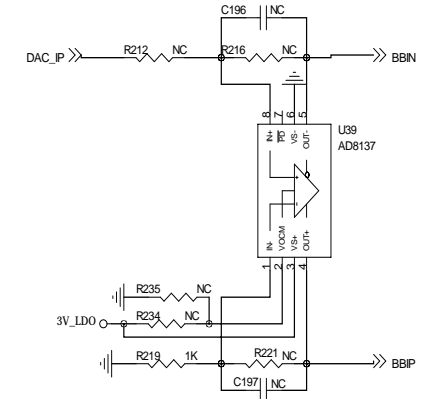
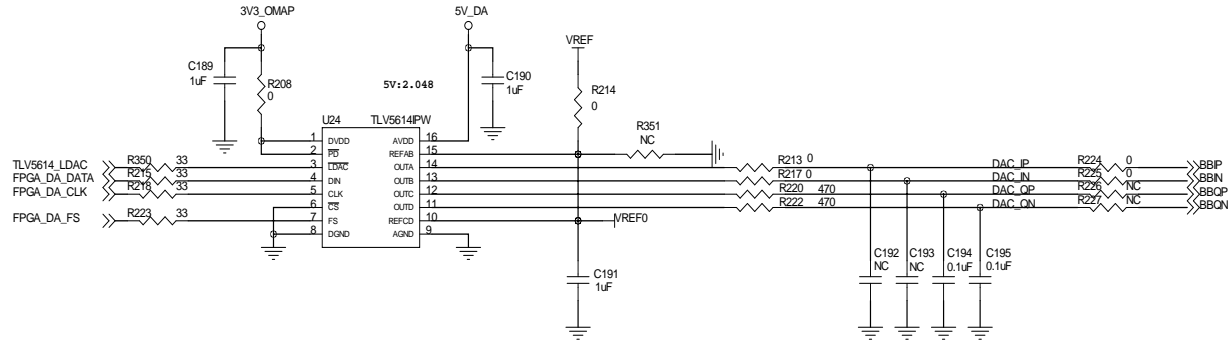
EP4CE30F484  
VERSION : 1.0  
PAGE : 2 of 8  
DATE : APRIL 2010



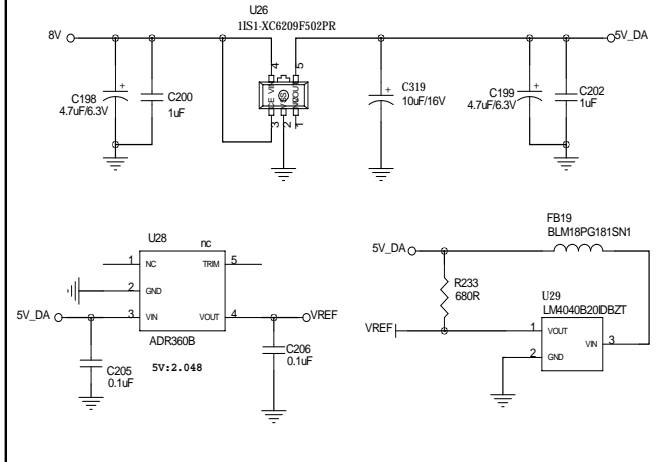




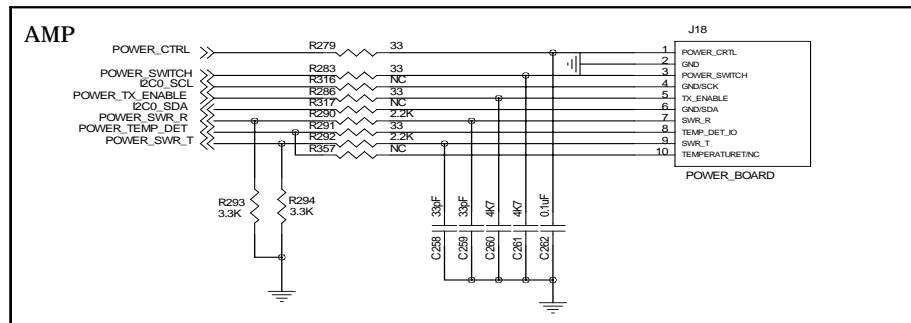
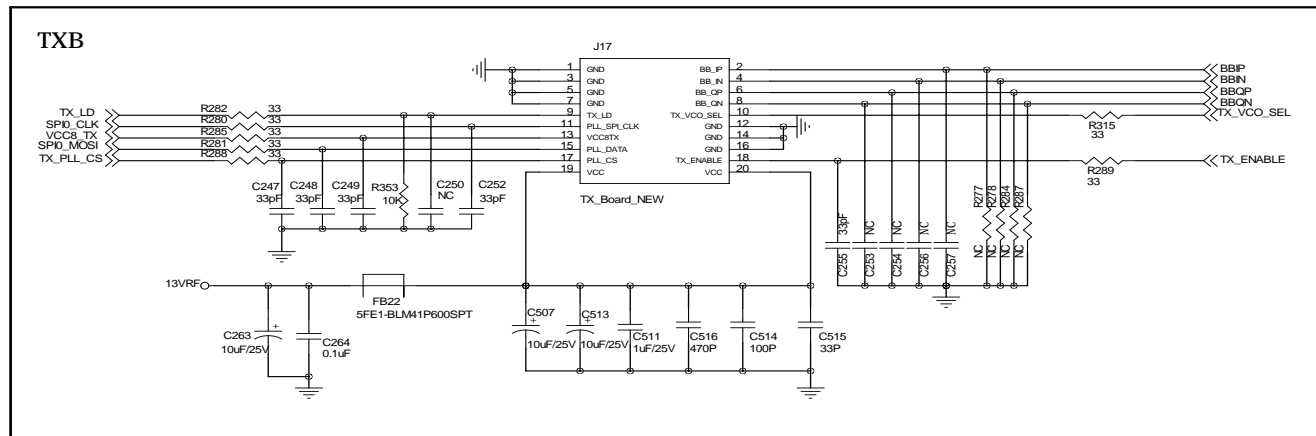
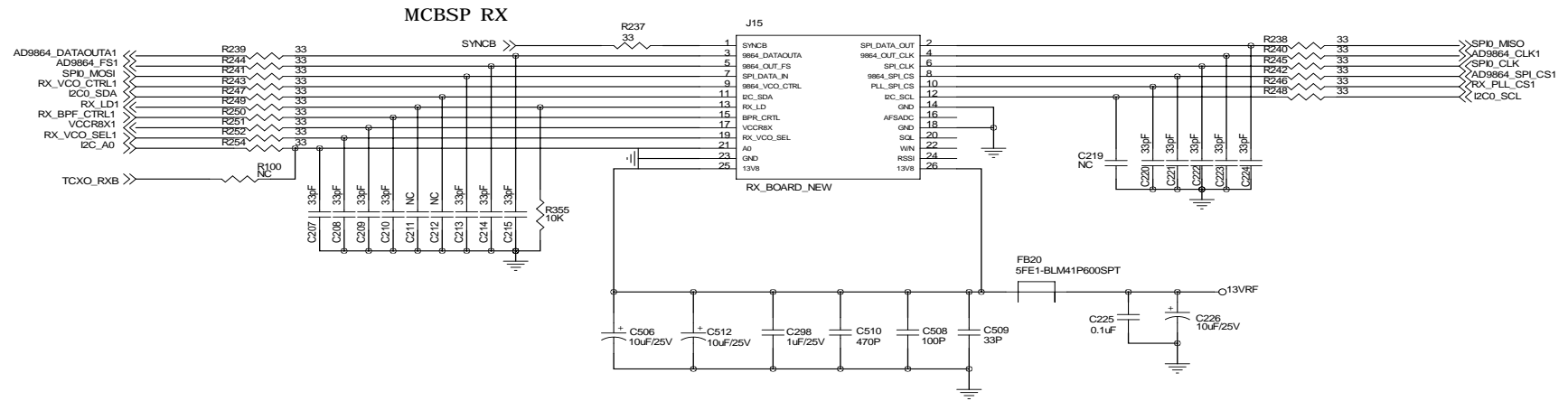
DA

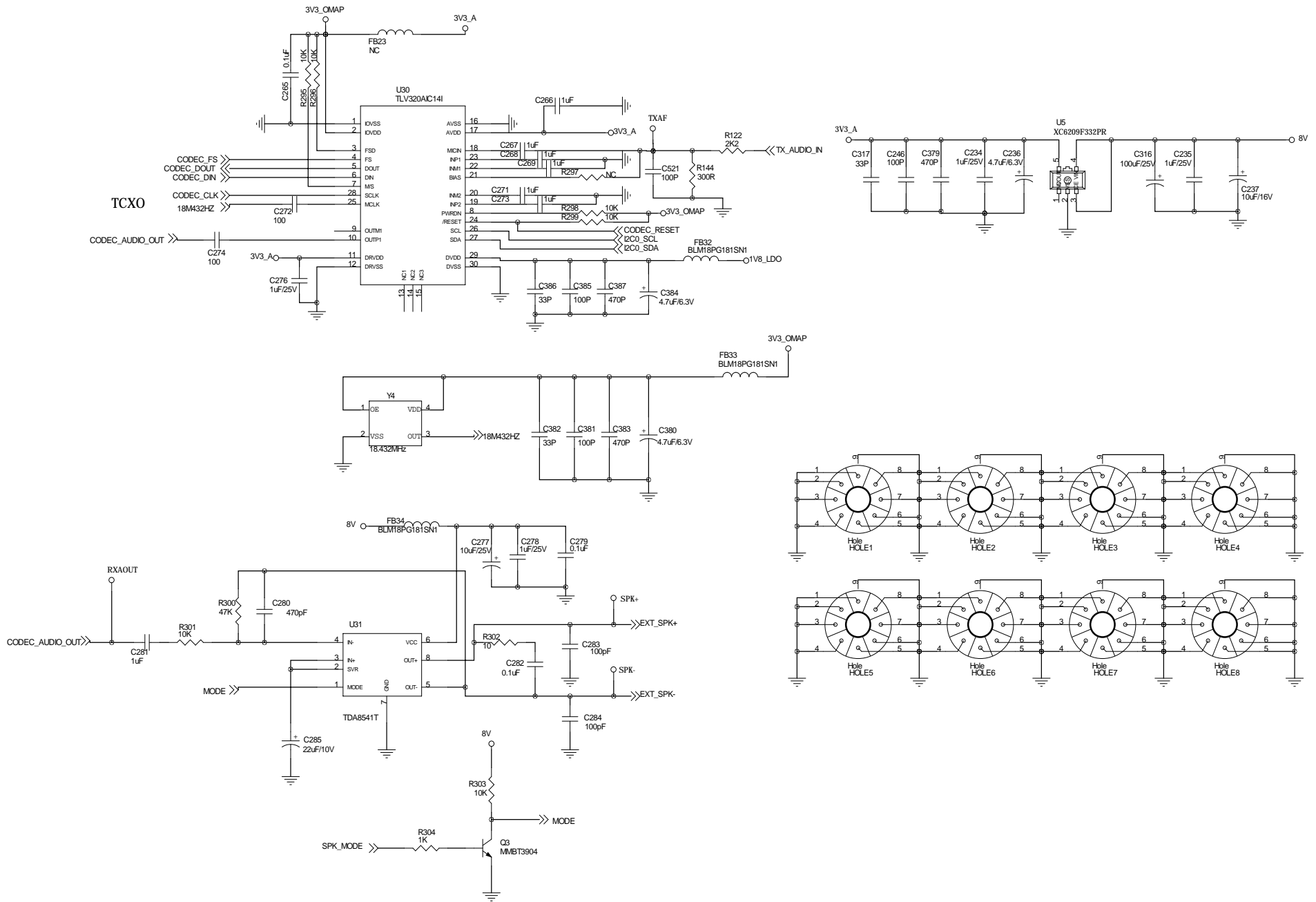


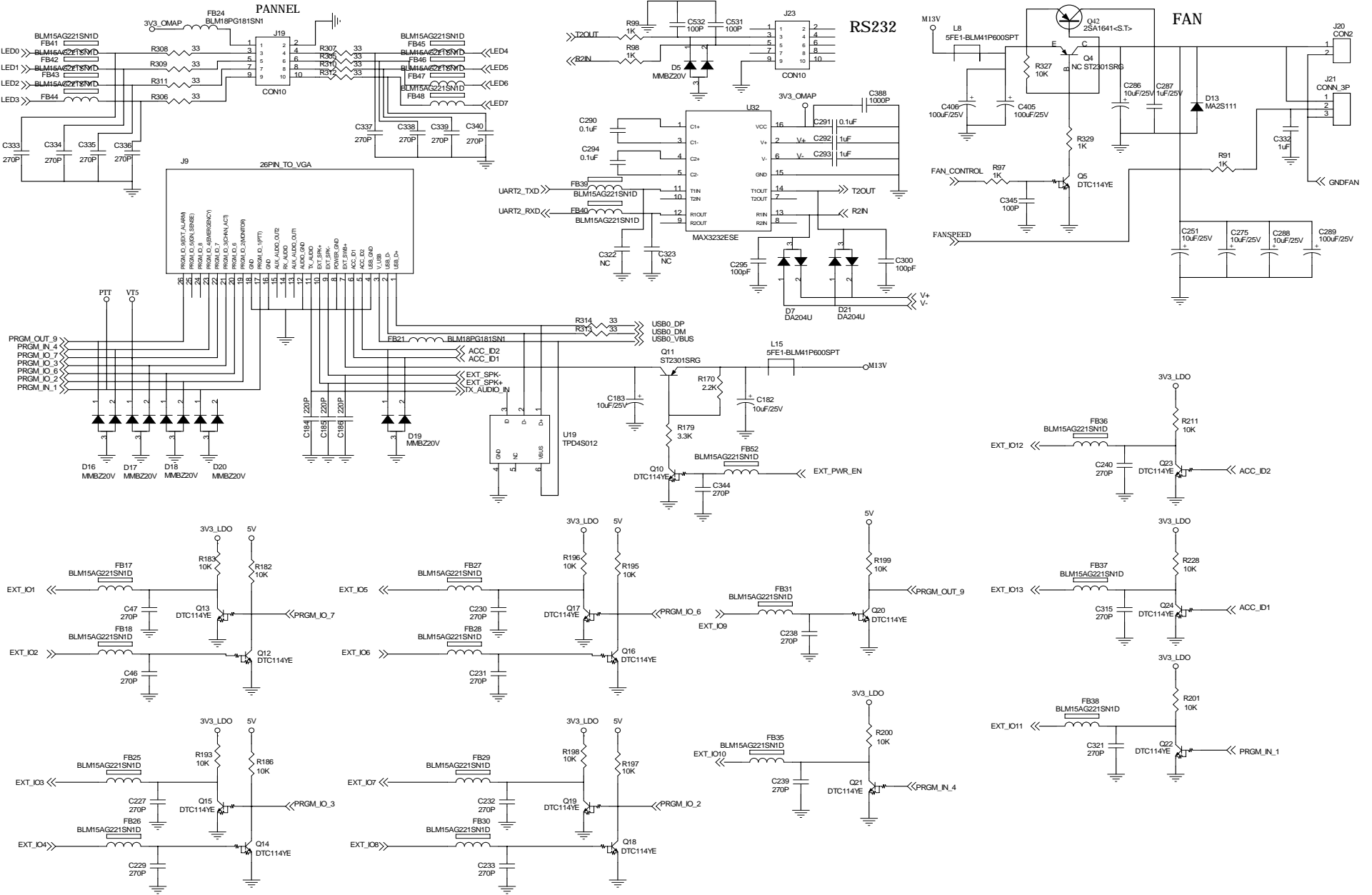
DA REF



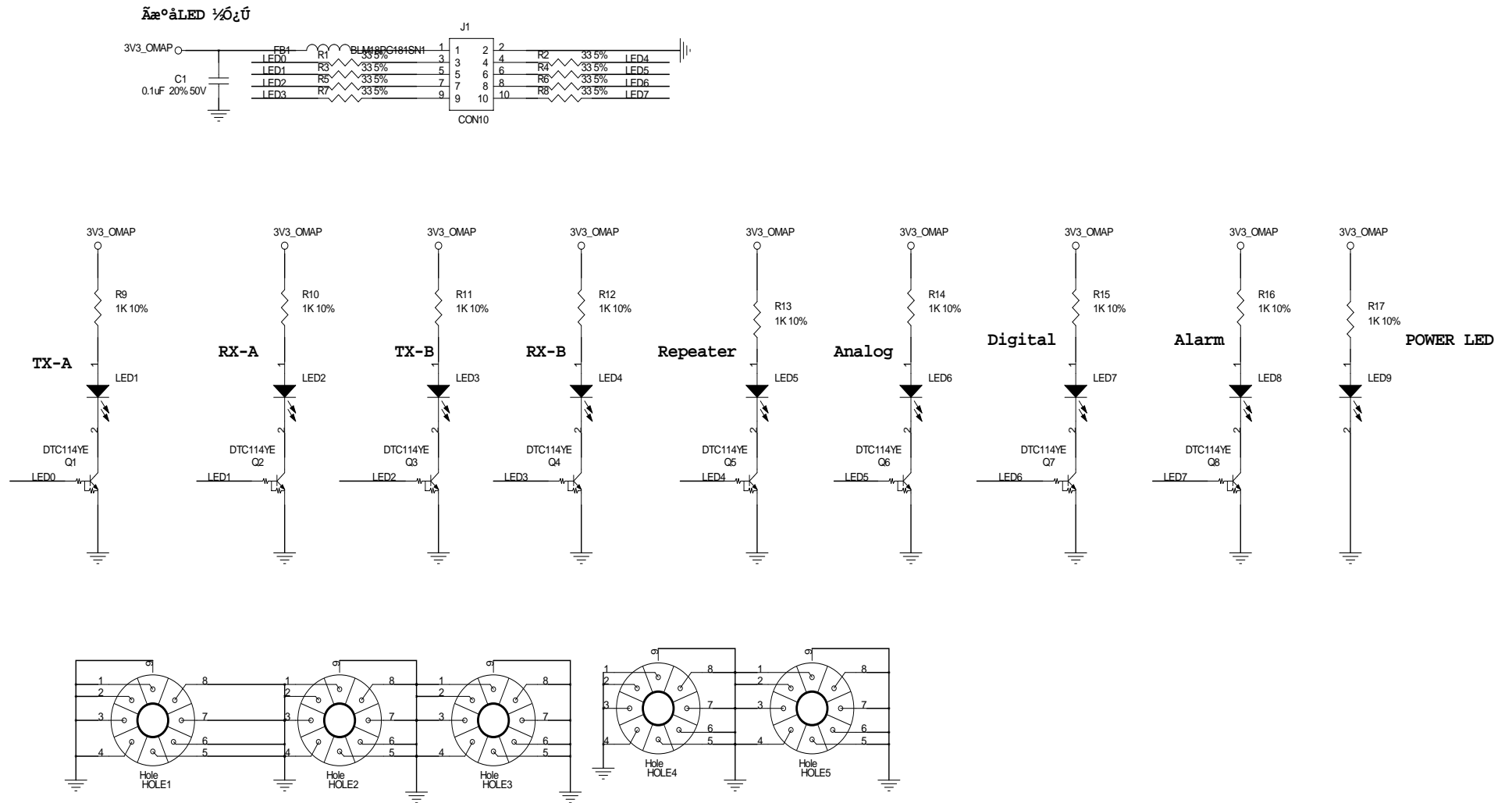




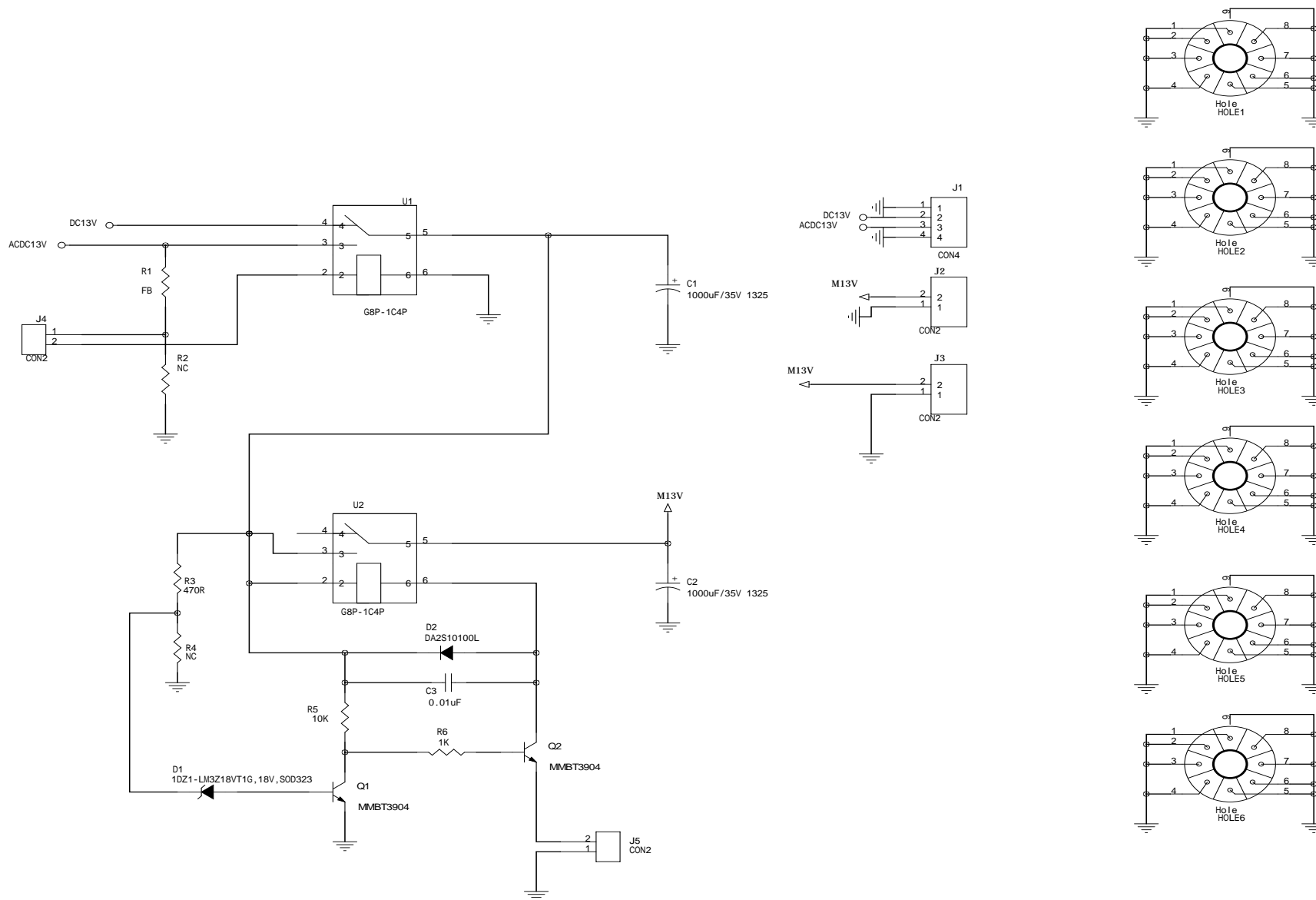




# Figure 17 Front Panel Schemetic Diagram



# Figure 18 Power Board Schematic



# Figure 19 Accessory Schematic Diagram

